

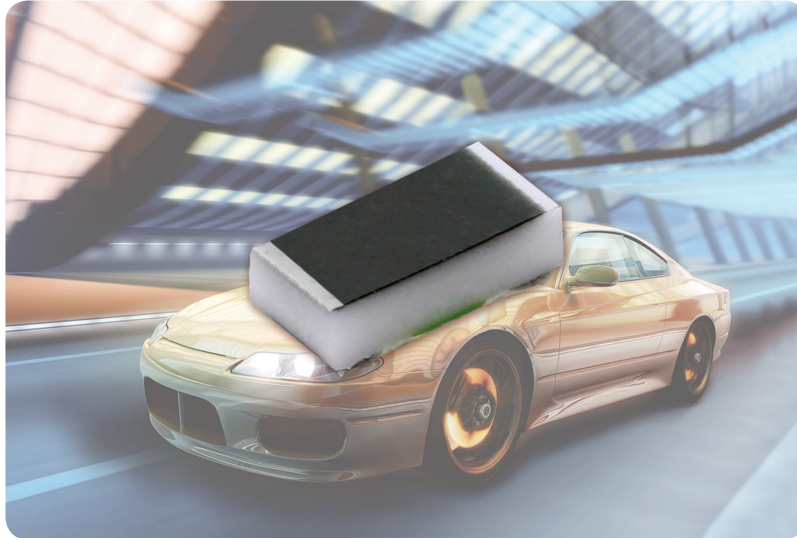

# THICK FILM CHIP RESISTORS

RCA-AP e4

## Robust Thick Film Chip Resistors for Conductive Gluing



### KEY BENEFITS

- AgPd terminations for conductive gluing
- Superior resistance against H<sub>2</sub>S atmosphere according to ASTM B809-95
- Reduced package footprint compared to solderable products
- Low parasitic capacitance and inductance compared to standard products
- Enhanced operating temperature (175 °C, 1000 h)
- AEC-Q200 qualified

### APPLICATIONS

- Automotive
- Industrial

### RESOURCES

- Datasheet: RCA-AP e4 - [www.vishay.com/doc?20062](http://www.vishay.com/doc?20062)
- For technical questions contact [thickfilmchip@vishay.com](mailto:thickfilmchip@vishay.com)
- Material categorization: For definitions please see [www.vishay.com/doc?99912](http://www.vishay.com/doc?99912)



**RoHS**  
COMPLIANT

**HALOGEN**  
**FREE**

A **WORLD OF**  
**SOLUTIONS**

### Robust Thick Film Chip Resistors for Conductive Gluing

TECHNICAL SPECIFICATIONS	
DESCRIPTION	RCA0603-AP e4
Imperial size	0603
Metric size code	RR1608M
Resistance range	1 $\Omega$ to 10 M $\Omega$ ; jumper (0 $\Omega$ )
Resistance tolerance	$\pm 5\%$ ; $\pm 1\%$
Temperature coefficient	$\pm 200$ ppm/K; $\pm 100$ ppm/K
Rated dissipation, $P_{70}$ <sup>(1)</sup>	0.15 W
Operating voltage, $U_{max}$ AC <sub>RMS</sub> /DC	75 V
Permissible film temperature, $\vartheta_{F max}$ <sup>(1)</sup>	175 °C
Operating temperature range	-55 °C to +175 °C
Permissible voltage against ambient (insulation): 1 min, $U_{ins}$	100 V

#### Notes

- An appropriate thermal resistance  $R_{th}$  has to be realized by adequate gluing connection and board material.
- <sup>(1)</sup> Please refer to APPLICATION INFORMATION below.

#### APPLICATION INFORMATION

When the resistor dissipates power, a temperature rise above the ambient temperature occurs, dependent on the thermal resistance of the assembled resistor together with the printed circuit board. The rated dissipation applies only if the permitted film temperature is not exceeded.

These resistors do not feature a limited lifetime when operated within the permissible limits. However, resistance value drift increasing over operating time may result in exceeding a limit acceptable to the specific application, thereby establishing a functional lifetime.

#### DIMENSIONS

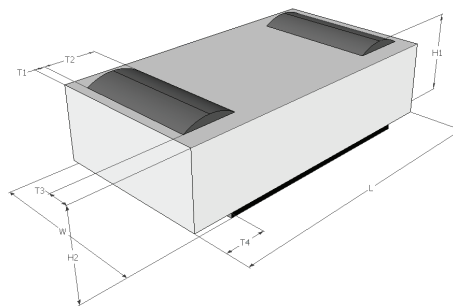

DIMENSIONS AND MASS									
TYPE / SIZE	L (mm)	W (mm)	H (mm)	T1 (mm)	T2 (mm)	T3 (mm)	T4 (mm)	H1 - H2 (mm)	MASS (mg)
RCA0603-AP	1.55 + 0.10/ -0.05	0.85 $\pm$ 0.1	0.45 $\pm$ 0.05	0.05 $\pm$ 0.05	0.275 + 0.1/ -0.05	0.1 $\pm$ 0.025	0.3 $\pm$ 0.2	10 - 40	2

Revision 24-Feb-15