



SENSING AND CONTROL

Sensors and Switches for Potential Medical Applications



Potential Medical Applications Overview

Potential Application	Honeywell Product	Product Function in Application	Customer Benefits
RESPIRATORY			
Anesthesia Delivery Machines	Airflow Sensor	measures the flow of air, oxygen and nitrous oxide so that the specified mixture, as set by the doctor, is delivered to the patient	improves patient comfort, eases patient breathing, reliable
	Hall-Effect Magnetic Position Sensor	provides enhanced output accuracy for smooth motor control that reduces noise and vibration in motor assembly fan systems	quiet, cost-effective, efficient, effective, accurate
	Pressure Sensor – Silicon		
	Pressure Sensor – Stainless Steel Media Isolated	measures air and oxygen pressure so that the pressure doesn't exceed a desired level	stable, easy to use, accurate, improves patient safety, easy to design in, compatible
	Thermistor	monitors and controls the air temperature	flexible, cost-effective, small size
Oxygen Concentrators	Airflow Sensor	detects ultra-low levels at 0.1 cm ³ to detect when the patient exhales and when the system should reduce airflow	improves patient comfort, eases patient breathing, quiet, portable, reliable
	Hour Meter	tracks machine usage in hours and tenths of an hour via a readily-visible readout	accurate, reliable, readable, rugged
	Pressure Sensor – Silicon	detects when the patient begins to inhale so that oxygen can then be delivered efficiently and effectively	stable, sensitive, accurate, reliable, cost-effective, efficient
	Pressure Sensor – Stainless Steel Media Isolated	senses pressure from the surge tank, providing feedback to the compressor which allows the compressor to maintain the desired pressure level	sensitive, accurate, reliable, cost-effective, efficient
	Pressure Switch	acts as a high pressure warning, alerting the user by activating an indicator light in the pressure exceeds a specified limit	accurate, reliable, extended life, one-stop shopping
Sleep Apnea Machines	Airflow Sensor	monitors the patient's breathing and sends an output that reduces the flow of the machine's internal blower fan when the patient starts to exhale	improves patient comfort, eases patient breathing, quiet, portable, reliable
	Flexible Heater	vaporizes water so that a comfortable breathing environment can be provided	flexible, customizable, improves patient comfort, improves patient safety, stable, easy to implement
	Hall-Effect Magnetic Position Sensor	provides enhanced output accuracy for smooth motor control that reduces noise and vibration in motor assembly fan systems	quiet, cost-effective, improves patient safety, efficient, effective, accurate
	Humidity Sensor	monitors the amount of humidified air to provide adequate air moisture to the patient	accurate, flexible, cost-effective, durable
	Pressure Sensor – Silicon	monitors the pressure of air that is delivered to the patient	stable, reliable, efficient, accurate, sensitive
	Thermistor and Pre-Packaged Temperature Probe	provide warm, moist air	accurate, effective design, flexible
Ventilators	Airflow Sensor	measures the flow of air, oxygen and nitrous oxide so that the specified mixture, as set by the doctor, is delivered to the patient	improves patient comfort, eases patient breathing, reliable
	Flexible Heater	heats water to a vapor and introduces it into the air stream	flexible, customizable, improves patient comfort and safety, stable, easy to implement
	Hall-Effect Magnetic Position Sensor	provides enhanced output accuracy for smooth motor control that reduces noise and vibration in motor assembly fan systems	quiet, cost-effective, improves patient safety, efficient, effective, accurate
	Humidity Sensor	helps deliver warm and moist air by being coupled to a microcontroller designed to measure the humidity of the air stream and signal the controller that the desired level of moisture is present	accurate, flexible, cost-effective, durable
	Pressure Sensor – Silicon	measures air and oxygen pressure so that the pressure doesn't exceed a desired level	stable, easy to use, accurate, improves patient safety, easy to design in
	Pressure Sensor – Stainless Steel Media Isolated	provides a sensing solution when high pressure, steel pressure port interface and/or corrosive media are used	easy to use, accurate, improves patient safety, easy to design in
	Thermistor	monitors and controls the air temperature	flexible, cost-effective, small
KIDNEY DIALYSIS MACHINES			
Kidney Dialysis Machines	Flexible Heater	provides controlled heat for blood or dialysate warming to body temperature prior to re-entry into the body	flexible, customizable, enhances patient comfort, improves patient safety, stable, simplifies system qualification
	Force Sensor	a) detects the presence or absence of a fresh dialysate cartridge before the machine can be used; b) monitors the flexible tubing pressure of the dialysate to detect that the pressure doesn't exceed a specified level; c) monitors the weight of the dialysate to detect whether there is a specified amount of dialysate in the fresh dialysate cartridge	reliable, sensitive, stable
	Hall-Effect Magnetic Position Sensor	provides reliable, accurate output for smooth motor control that reduces noise and vibration in the machine's motor assembly and improves its efficiency	quiet, cost-effective, energy-efficient, accurate
	Infrared Sensor	used with an encoder wheel on the pump shaft to count shaft rotation	reliable, works in contaminated environments, enables maximum position resolution

Potential Application	Honeywell Product	Product Function in Application	Customer Benefits
Kidney Dialysis Machines (Continued)	Pressure Sensor – Silicon	obtains a direct, in-line continuous dialysate and venous pressure measurement in the dialysis membrane without interrupting flow	stable, efficient, accurate, easy to design in, small, extended life
	Pressure Sensor – Stainless Steel Media Isolated	when located in a Fresh Dialysate Cartridge, may be used to monitor pressure in the flexible tubing that carries blood or dialysate to provide continuous feedback of line pressures and pump control	
	Thermistor	provides temperature measurement for enhanced control of the permeation rate across the dialysis membrane	allows application flexibility, cost-effective, small
INFUSION AND INSULIN PUMPS			
Infusion and Insulin Pumps	Flexible Heater	conforms to the infusion pump's surface that requires heating, allowing for the capability of maintaining specific temperatures at predetermined levels	allows application flexibility, customizable, improves patient safety, stable, simplifies system qualification
	Force Sensor	provides an occlusion detector to detect blockage in the infusion or insulin pump's tube that delivers the medication to the patient	sensitive, stable, reliable, easy to use, portable
	Hall-Effect Magnetic Position Sensor	provides reliable, accurate output for smooth motor control that reduces noise and vibration in the pump's motor assembly and improves its efficiency	quiet, cost-effective, energy-efficient, accurate
	Infrared Sensor	used with an encoder wheel on the pump shaft to count shaft rotation	reliable, works in contaminated environments, enables maximum position resolution
	Pressure Sensor	monitor and control the flow of fluid	accurate, easy to design in, stable
HOSPITAL DIAGNOSTICS			
Gas Chromatography	Airflow Sensor	regulates the flow rate to eliminate outgasing	reliable, reduces risk of contamination, accurate, stable, easy to implement
Hematology Analyzers	Infrared Sensor	used with an encoder wheel on the pump shaft to count shaft rotation	reliable, operates in contaminated environments, enables maximum position resolution
Blood Analyzers	Pressure Sensor – Silicon	regulates pressure in the pump system to draw and transport the samples	accurate, reliable, stable, repeatable, contaminant and corrosion resistant, product availability
	Thermistor	monitors the temperature of the chamber, diffusion lamps and oil-cooled motors to prevent overheating	allows application flexibility, cost-effective, small
PATIENT MONITORING SYSTEMS			
Respiratory Monitoring	Airflow Sensor	monitors patient's respiratory function	improves measurement sensitivity and accuracy, portable, reliable
Respiratory Monitoring and Blood Pressure Monitoring	Pressure Sensor – Silicon	measures air and oxygen pressure	stable, accurate, fast response time, easy to design in, portable
Blood Glucose Monitoring	Pressure Sensor – Silicon	controls the pumps used to draw the blood and return it to the patient so that the pressure does not rupture the veins	improves patient safety with enhanced stability and low drift, fast response time, easy to design in, portable
Temperature Monitoring	Thermistor	monitors patient temperature	allows application flexibility, cost-effective, small
HOSPITAL HARDWARE			
Medication Dispensing Cabinets	Hall-Effect Magnetic Position Sensor	enables remote locking and unlocking of medication dispensing cabinet drawers	allows for enhanced security, minimizes medication dispensing errors, reliable, cost-effective, energy-efficient, size reduction, on-time delivery
Medical Incubators	Humidity Sensor	monitors the medical incubator system to maintain a desired level of humidification in the chamber with accurate dew-point and absolute humidity/moisture measurement	stable, reliable, allows application flexibility, cost-effective, durable
	Thermistor	monitors temperature	allows application flexibility, cost effective, small
Blood Pressure Monitors	Pressure Sensor – Silicon	measures blood pressure	portable, stable, accurate
Hospital Beds	MICRO SWITCH™ Position Switch	determines minimum and maximum position of electrically adjustable hospital beds	accurate, repeatable, durable, effective design, small, light weight
	Pressure Sensor – Silicon	measures air pressure and controls the inflation and deflation of the mattress air columns to prevent bedridden patients from developing bedsores	accurate, reliable, stable
SURGICAL INSTRUMENTS			
Surgical Fluid Management Systems	Force Sensors	can help regulate the pressure at the pump head of a fluid management system, and as a back-up safety device to the direct pressure measurement at the joint	rugged design, stable, reliable, portable and energy-efficient
	Pressure Sensor – Silicon	sense pressure directly at the joint site during arthroscopic surgery	accurate, improves patient safety, easy to design in
DENTAL EQUIPMENT			
Dental Imaging Systems and Dental Chairs	Hall-Effect Magnetic Position Sensor	provides accurate motion control and positioning of the dental imaging system	accurate, energy-efficient, fast response, reliable
Dental Imaging Systems	Infrared Sensor	obtains dental images	reliable, works in contaminated environments, enables maximum position resolution
Pressure-Operated Dental Instruments (e.g., drills, water sprays, air blasters)	Pressure Sensor – Silicon	keeps the water flow constant and at an adjusted level, allowing smooth operation of the dental instrument	accurate, reliable, stable, water-resistant, contaminant-resistant



Table of Contents

Respiratory

Anesthesia Delivery Systems 4

- Airflow Sensors
- Hall-Effect Magnetic Position Sensors
- Pressure Sensors
- Thermistors

Oxygen Concentrators 7

- Airflow Sensors
- Hour Meters
- Pressure Sensors
- Pressure Switches

Sleep Apnea Machines 10

- Airflow Sensors
- Flexible Heaters
- Hall-Effect Magnetic Position Sensors
- Humidity Sensors
- Pressure Sensors
- Thermistors and Pre-Packaged Temperature Probes

Ventilators 14

- Airflow Sensors
- Flexible Heaters
- Hall-Effect Magnetic Position Sensors
- Humidity Sensors
- Pressure Sensors
- Thermistors

Kidney Dialysis Machines 18

- Flexible Heaters
- Force Sensors
- Hall-Effect Magnetic Position Sensors
- Infrared Sensors
- Pressure Sensors
- Thermistors

Infusion, Insulin or Syringe Pumps 22

- Flexible Heaters
- Force Sensors
- Hall-Effect Magnetic Position Sensors
- Infrared Sensors
- Pressure Sensors

Hospital Diagnostics 25

- Airflow Sensors
- Infrared Sensors
- Pressure Sensors
- Thermistors

Patient Monitoring Systems 28

- Airflow Sensors
- Pressure Sensors
- Thermistors

Hospital Hardware 30

- Hall-Effect Magnetic Position Sensors
- Humidity Sensors
- MICRO SWITCH™ Position Switches
- Pressure Sensors
- Thermistors

Surgical Instruments 33

- Force Sensors
- Pressure Sensors

Dental Equipment 34

- Hall-Effect Magnetic Position Sensors
- Infrared Sensors
- Pressure Sensors



For innovation that's well apart, there's only Honeywell Sensing and Control.

With more than 50,000 products ranging from snap-action, limit, toggle and pressure switches to position, speed, pressure and airflow sensors, Honeywell Sensing and Control (S&C) has one of the broadest sensing and switching portfolios available.

Honeywell sensor, switch and control components are tailored to exact specifications for stronger performance, longer productivity and increased safety. Enhanced accuracy and durability are built into every part, improving output and endurance. For our customers, this can reduce expenditures and operational costs. Our global footprint and channels help to competitively price such components for your chosen application and provide immediate technical support.

Our expertise in medical, aerospace and defense, transportation and industrial industries means we offer products and solutions for a wide range of applications. But, an impressive product line is only one part. We possess unique engineering expertise and value-added capabilities.

While Honeywell's switch and sensor solutions are suitable for a wide array of basic and complex applications, our custom engineered solutions offer enhanced precision, repeatability

and ruggedness. We offer domain knowledge and technology resources, along with a close working relationship, to develop and deliver cost-effective, individually tailored solutions. Whether clean-slate development or simple modifications to an existing design are needed, our expertly engineered solutions help to meet the most stringent requirements with world-class product designs, technology integration and customer-specific manufacturing.

With a 75-year legacy in the switch and sensor business, Honeywell S&C has earned a reputation for reliability and excellence. Our strong product designs, Six Sigma Plus manufacturing environment and robust testing facilities help provide quality out-of-the-box, as well as enhanced, sustainable performance down the line.

Global service, sourcing and manufacturing. Industry-leading engineers. Value-added assemblies and solutions. Construction to required specifications. A one-stop, full-service, globally competitive supplier... Honeywell Sensing and Control.



Respiratory

Honeywell is a leading sensor provider for many potential respiratory applications due to delivering the lowest pressure drop in the industry while providing enhanced sensitivity, accuracy, reliability and stability with minimal drift over time. Honeywell's sensors and switches can be used in a variety of potential respiratory applications, including anesthesia delivery systems, oxygen concentrators, sleep apnea machines and ventilators.



Respiratory: Anesthesia Delivery Systems

An anesthesia machine is designed to deliver drugs to patients to help eliminate pain and other unwanted sensations. The continuous flow anesthetic machine provides an accurate and constant supply of medical gases (such as air, oxygen and nitrous oxide), mixed with an accurate concentration of anesthetic vapor (such as isoflurane), and delivers this mixture to the patient at a desired pressure and flow.

Sensor Solutions for Anesthesia Delivery Systems

- Airflow Sensors
- Hall-Effect Magnetic Position Sensors
- Pressure Sensors
- Thermistors

Airflow Sensors in Anesthesia Delivery Systems

AWM700 Series (AWM720P1), AWM5000 Series (AWM5104VN, AWM43300V, AWM3100V)

The AWM700 Series is designed to measure the flow of air, oxygen and nitrous oxide so that the specified mixture, as set by the doctor, is delivered to the patient. The total mixture that is delivered to the patient is also measured and displayed on the anesthesia machine's panel. The AWM5000 Series may also be used; however, these are lower flow devices and may require a customer created bypass.

Benefits to Customer

- **Eases patient's breathing:** Lowest pressure drop in the industry (to 0.2 cm H₂O at 200 SLPM) provides lower flow resistance, easing breathing.
- **Improves patient's comfort:** Enhanced sensitivity (the ability to detect ultra-low flow levels at 0.1 cubic centimeters) allows the sensor to detect when the patient exhales, sending a signal to reduce airflow, which eases the patient's exhalation and improves patient comfort.

- **Reliable:** Enhanced quality and reliability (<100 ppm) and optional manifold mounting capability reduce downtime in demanding operations.



AWM700 Series



AWM5000 Series

Hall-Effect Magnetic Position Sensors in Anesthesia Delivery Systems

SS400 Series

The Hall-effect magnetic position sensor is designed to provide enhanced output accuracy for smooth motor control that reduces noise and vibration in a variety of potential applications, including anesthesia machine motor assembly fan systems. Its small size often allows for design into many compact, automated, lower-cost assemblies. A thermally balanced integrated circuit that is accurate over a full temperature range is designed to provide proper fan functionality.

Benefits to Customer

- **Accurate:** Enhanced accuracy and linearity over-span of 0~5 V output enables an extended sensing range.
- **Circuit protection:** Reverse voltage/polarity protection provides circuit protection.
- **Cost-effective:** Small sensor size can allow for compact designs and automated, lower-cost assemblies.
- **Effective:** Thermally-balanced integrated circuit that is accurate over the full temperature range enhances proper fan function.

- **Energy-efficient:** Low power consumption enhances energy efficiency.
- **Quiet:** Industry-leading sensor output accuracy for smooth motor control enables low audible noise and reduces motor vibration.



SS400 Series

Pressure Sensors in Anesthesia Delivery Systems

Silicon: TruStability™ (HSC Series, SSC Series), ASDX Series, CPC Series (CPCL10GFC), SDX Series (SDX010IND4)
Stainless Steel Media Isolated: MLH Series, 19mm Series, SPT Series

Honeywell's TruStability™ and ASDX Series silicon pressure sensors are designed to measure air and oxygen pressure so that the pressure doesn't exceed a desired level. The CPC Series and the SDX Series may also be used with a customer-provided amplifier or an ASIC-based solution for a signal conditioned output. The MLH Series, 19 mm Series and SPT Series stainless steel media isolated pressure sensors are designed to provide a sensing solution when high pressure, steel pressure port interface and/or corrosive media are used. A male threaded pressure port and stainless steel wetted surfaces provide an air and oxygen inlet.

- TruStability™ sensors' exceptional accuracy is a result of leading-edge technology, precise manufacturing processes and temperature compensation and calibration. TruStability™ sensors have two levels of accuracy: the standard accuracy SSC Series offers $\pm 2\%$ total error band, and the HSC Series offers $\pm 1\%$ total error band, better than most competitive products.
- ASDX Series offers accuracy of $\pm 2\%$.
- MLH Series' accuracy depends upon the pressure range: above 300 psi 0.25% FSS; below 300 psi 0.5% FSS; 19 mm Series offers 0.25% FSS; SPT Series offers 0.25% FSS.

- **Easy to design in:** Customization of desired pressure ranges, connections, calibration and temperature compensation minimizes design-in effort.
- **Easy to use:** Small package with integrated signal conditioning reduces the number of components needed to implement the sensor, enabling size reduction of the end product.
- **Safe:** Enhanced accuracy, sensitivity and stability with minimal drift over time and temperature enhances patient safety and therapy effectiveness by sensing when patients are breathing on their own to wean off the device.
- **Stable:** Stability is a measure of how little the output signal of the pressure sensor will change from measurement to measurement. The long-term stability of Honeywell's TruStability™ sensors is the best in the industry.

Benefits to Customer

- **Accurate:** Enhances patient safety by measuring volume and mixture of gases to deliver the mixture at a desired pressure and flow.

- **Compatible:** Wetted materials or media isolated packaging (materials resistant to certain contaminants or media) offer compatibility with many harsh environments and resistance to certain contaminants.



TruStability™ HSC Series, SSC Series



ASDX Series



CPC Series



SDX Series



MLH Series



19 mm Series



SPT Series

Thermistors in Anesthesia Delivery Systems

192 Series, 194 Series

Air from anesthesia machines that is warm and moist helps to provide the patient with a comfortable breathing situation and may reduce sore throats caused by breathing cold, dry air. As such, the temperature of the air delivery system is often monitored and controlled to provide an air stream at a desired level of warmth. Discrete thermistor temperature sensors are installed directly into the air stream and are designed to monitor the air temperature. The sensor is coupled to a microcontroller designed to measure air stream temperature and interact with the controller that regulates the temperature of the air stream. Honeywell offers several types of configurations. The packaged sensors are available as discrete components for customer-built assemblies, or Honeywell can provide a full assembly solution that the customer may simply pigtail into the system.

Benefits to Customer

- **Cost-effective:** Resistance temperature curve interchangeability designed to offer standardization of circuit components and simplification of design/replacement enhances cost-effectiveness.
- **Flexible:** Bare leads (192 Series) or insulated leads (194 Series) are designed to provide application flexibility.
- **Small:** Small size often eases use in confined spaces.



192 Series



194 Series

Anesthesia Delivery Machine Block Diagram

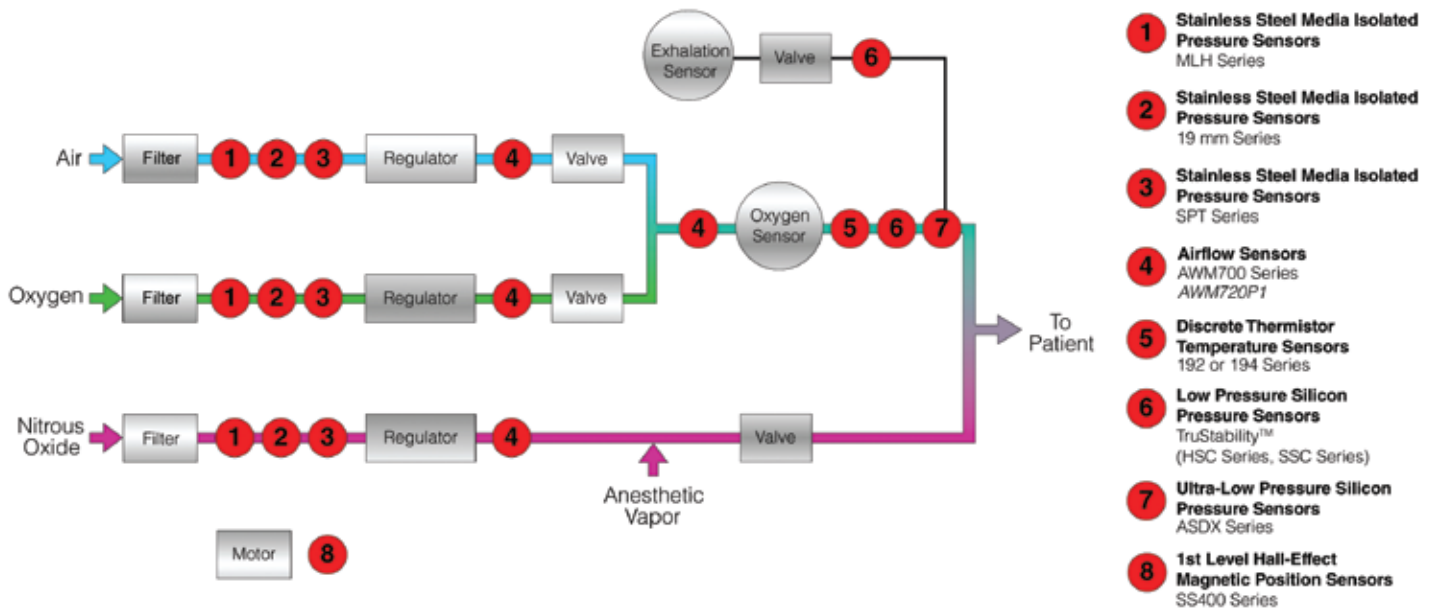

- 1 **Stainless Steel Media Isolated Pressure Sensors**
MLH Series
- 2 **Stainless Steel Media Isolated Pressure Sensors**
19 mm Series
- 3 **Stainless Steel Media Isolated Pressure Sensors**
SPT Series
- 4 **Airflow Sensors**
AWM700 Series
AWM720P1
- 5 **Discrete Thermistor Temperature Sensors**
192 or 194 Series
- 6 **Low Pressure Silicon Pressure Sensors**
TruStability™
(HSC Series, SSC Series)
- 7 **Ultra-Low Pressure Silicon Pressure Sensors**
ASDX Series
- 8 **1st Level Hall-Effect Magnetic Position Sensors**
SS400 Series

Respiratory: Oxygen Concentrators

An oxygen concentrator reduces the amount of nitrogen in the air, increasing the oxygen level delivered to the patient. Oxygen concentrators are used with patients, such as those with lung disease, who have difficulty absorbing oxygen into the blood stream.

Sensor and Switch Solutions for Oxygen Concentrators

- Airflow Sensors
- Hour Meters
- Pressure Sensors
- Pressure Switches



Airflow Sensors in Oxygen Concentrators

AWM90000 Series (AWM92100V)

Honeywell's airflow sensor for oxygen concentrators is designed to detect ultra-low flow levels at 0.1 cubic centimeters. This enhanced sensitivity may be used to detect when the patient exhales and when the system should reduce airflow, easing exhalation and improving patient comfort. Honeywell's airflow sensors deliver a low pressure drop (down to 0.2 cm H₂O at 200 SLPM), leading to lower flow resistance and improved patient comfort.

Benefits to Customer

- Eases patient's breathing:** Delivers the lowest pressure drop in the industry (to 0.2 cm H₂O at 200 SLPM), providing lower flow resistance, which eases breathing.
- Improves patient's comfort:** Enhanced sensitivity (the ability to detect ultra-low flow levels at 0.1 cubic centimeters) allows the sensor to detect when the patient exhales, sending a signal to reduce airflow, which eases the patient's exhalation and improves patient comfort.

- Portable:** Small sensor package size allows system size reduction, increasing portability, which can improve a patient's quality of life.
- Quiet:** Lower blower motor resistance allows for a quieter operation, improving the patient's ability to sleep.
- Reliable:** Enhanced quality and reliability (<100 ppm) can reduce downtime in many demanding operations.



AWM90000 Series

Hour Meters in Oxygen Concentrators

28000 Series

Honeywell's AC hour meter can track machine usage in hours and tenths of an hour via a readily-visible readout. This information may then be used to validate total hours of machine operation for maintenance purposes or usage on a per-patient basis to determine compliance or enhance billing accuracy. Hour meters are frequently found on the external control panel and are usually activated by the motor or compressor.

Benefits to Customer

- Accurate:** Accuracy of $\pm 0.02\%$.
- Readable:** Meter is readable with the power off.

- Reliable:** High tolerance to vibration and shock.
- Rugged:** Displayed hours cannot be altered—tamper-proof.



28000 Series

Pressure Sensors in Oxygen Concentrators

Silicon: Ultra-Low Pressure Sensors: CPCL Series (CPCL04GFC, CPCL10GFC), DUXL Series (DUXL01D); Low Pressure Sensors: TruStability™ (HSC Series, SSC Series), CPC Series and SDX Series (SDX005IND4); Stainless Steel Media Isolated: MLH Series

The low and ultra-low silicon pressure sensors may be used to detect when the patient begins to inhale so that oxygen can then be delivered efficiently and effectively. Not only can this enhance system response time, it can also minimize wasting oxygen when the patient isn't inhaling, allowing the oxygen concentrator to be smaller and to operate more efficiently. Smaller equipment size also means lower power consumption, as well as greater portability. The MLH Series stainless steel media isolated device senses pressure from the surge tank, providing feedback to the compressor which allows the compressor to maintain the desired pressure level.

Benefits to Customer

- **Accurate and sensitive:** Provides an enhanced level of sensitivity and accuracy over the entire range. TruStability™ sensors' exceptional accuracy is a result of leading-edge

technology, precise manufacturing processes and temperature compensation and calibration. TruStability™ sensors have two levels of accuracy: the standard accuracy SSC Series offers $\pm 2\%$ total error band, and the HSC Series offers $\pm 1\%$ total error band, better than most competitive products.

- **Cost-effective:** Silicon pressure sensors optimize oxygen delivery, maximizing the amount of oxygen in the tank.
- **Efficient:** Stainless steel media isolated sensors allow the user to monitor pressure within the specified range and adjust as needed, enhancing oxygen efficacy.
- **Reliable:** Provide enhanced quality and reliability.
- **Stable:** Stability is a measure of how little the output signal of the pressure sensor will change from measurement to measurement. The long-term stability of Honeywell's TruStability™ sensors is the best in the industry.



TruStability™ HSC Series,
SSC Series



CPC/CPCL Series



DUXL Series



SDX Series



MLH Series

Pressure Switches in Oxygen Concentrators

5000 Series

Honeywell's 5000 Series pressure switch is often located on the output of the oxygen concentrator's pressure regulator to alert the user by activating an indicator light if the pressure exceeds a specified limit. In some cases, it may also shut down the motor. Honeywell's pressure switch products have enhanced reliability and accuracy with fast transfer times (5 ms).

Benefits to Customer

- **Accurate:** "Off the shelf" catalog pressure switch accurately monitors pressure level.
- **Extended life:** Rated at a 1 million cycle life allows for extended life of the product.

- **One-stop shopping:** Select from a family of applicable Honeywell products.
- **Reliable:** Reliable and repeatable set point minimizes costly repairs from over pressure.



5000 Series

Oxygen Concentrator Block Diagram

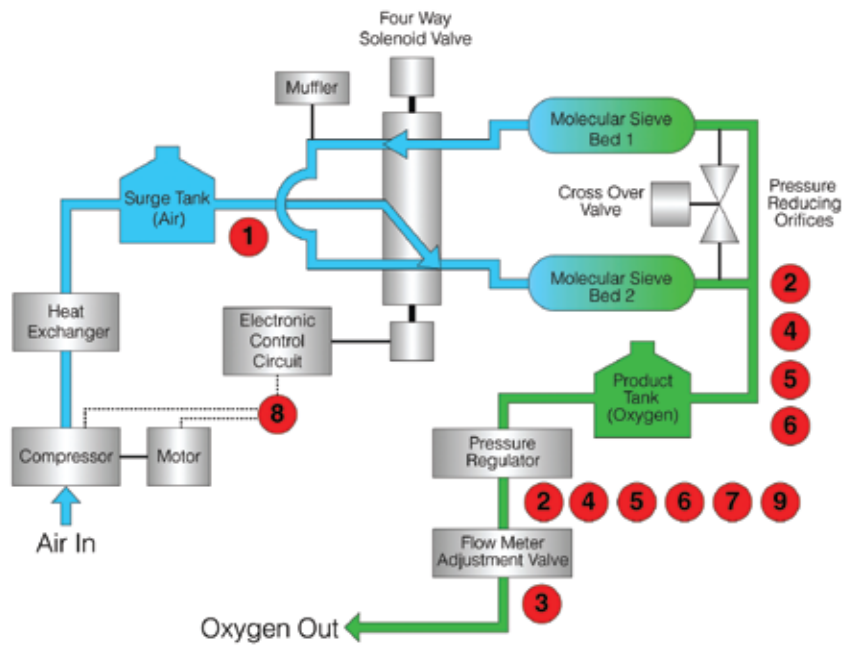

- 1 **Stainless Steel Media Isolated Pressure Sensors**
MLH Series
- 2 **Low Pressure Silicon Pressure Sensors**
TruStability™
(HSC Series, SSC Series)
- 3 **Ultra-Low Pressure Silicon Pressure Sensors**
CPCL Series
CPCL04
- 4 **Low Pressure Silicon Pressure Sensors**
CPC Series
- 5 **Ultra-Low Pressure Silicon Pressure Sensors**
DUXL Series
DUXL01D
- 6 **Low Pressure Silicon Pressure Sensors**
SDX Series
SDX005IND4
- 7 **Airflow Sensors**
AWM9000 Series
AWM92100V
- 8 **AC Hour Meters**
20000 Series
- 9 **Pressure Switches**
5000 Series



Respiratory: Sleep Apnea Machines

Sleep apnea is the repeated cessation of breathing during sleep, sometimes hundreds of times during the night and often for a minute or longer. If left untreated, sleep apnea may cause high blood pressure, cardiovascular disease, memory, and weight problems. The resulting lack of restful sleep may also be responsible for job impairment and motor vehicle accidents.

A main treatment option is the use of a Positive Airway Pressure (PAP) machine. The patient wears a mask that uses pressure to send air flowing through the nasal passages so they don't collapse and cause breathing to cease. There are three main categories of PAPs (in order of complexity/cost):

- **CPAP (Continuous Positive Airway Pressure)** provides a constant pressure to the patient. This positive pressure keeps the throat from collapsing during sleep and allows the patient to breathe freely without worry of episodes of non-breathing.
- **Auto-PAP (Automatic Positive Airway Pressure)** measures the resistance in a patient's breathing. The amount of continuous pressure delivered to the patient is then automatically tuned to the minimum required to maintain an unobstructed airway on a breath-by-breath basis.

- **Bilevel-PAP (Bilevel Positive Airway Pressure)** provides two levels of pressure: IPAP (Inspiratory Positive Airway Pressure) and a lower EPAP (Expiratory Positive Airway Pressure).

Sensor Solutions for Sleep Apnea Machines

Airflow Sensors

Flexible Heaters

Hall-Effect Magnetic Position Sensors

Humidity Sensors

Pressure Sensors

Thermistors and Pre-Packaged

Temperature Probes



Airflow Sensors in Sleep Apnea Machines

AWM90000 Series (AWM92100V), AWM700 Series (AWM720P1)

Honeywell's airflow sensors monitor the patient's breathing and send an output that informs the machine to reduce its internal blower fan when the patient starts to exhale. The resulting lowered resistance prevents the patient from feeling as though he is "fighting" against the machine when breathing, reducing discomfort. Patients often find that machines that use an airflow sensor to detect the breathing cycle tend to be more comfortable, and are more likely to use such machines more regularly than equipment without this feature. Some insurance companies and doctors often prefer this equipment due to greater patient compliance. These sensors have been used in Auto-PAP and Bilevel-PAP machines.

Benefits to Customer

- **Eases patient's breathing:** Delivers the lowest pressure drop in the industry (to 0.2 cm H₂O at 200 SLPM), providing lower flow resistance which eases breathing.

- **Improves patient's comfort:** Enhanced sensitivity (the ability to detect ultra-low flow levels at 0.1 cubic centimeters) allows the sensor to detect when the patient exhales, sending a signal to reduce airflow which eases the patient's exhalation and improves patient comfort.
- **Portable:** Small sensor package size allows system size reduction, increasing portability, which can improve a patient's quality of life.
- **Quiet:** Lower blower motor resistance allows for a quieter operation, improving the patient's ability to sleep.
- **Reliable:** Enhanced quality and reliability (<100 ppm) reduce downtime in many demanding operations.



AWM90000 Series



AWM700 Series

Flexible Heaters in Sleep Apnea Machines

A3100 Series, A3200 Series, A3400 Series, C3100 Series, C3200 Series, C3400 Series

A flexible heater is often required to warm water to vapor in the pump area to increase humidity so that a comfortable breathing environment can be provided to the patient. There are other ways of generating water vapor, such as misting valves, but using heat ensures a uniform, warm and moist breathing experience most preferred by patients. The heat is generally controlled by an onboard negative temperature coefficient (NTC) thermistor offering variable air temperature that, depending on the OEM, can adjust the vapor/air temperature to improve patient comfort.

Benefits to Customer

- **Customizable:** Capability to quickly customize flexible heater building block technology meets custom application requirements.
- **Eases system qualification:** Meets regulatory requirements, easing system qualification.
- **Flexible:** Numerous configurations (e.g., flat, molded-to-shape, spiral wrap, transparent, composite and high-temperature), a variety of manufacturing materials (e.g., silicone and other



3100 Series



3200 Series



3400 Series

- flexible dielectric components) and various watt densities (e.g., single, multiple or variable) increase application flexibility.
- **Improves patient's comfort:** Integration of mounting and sensing components allows for the desired vaporization of water, enhancing patient comfort.
- **Improves patient's safety:** Built-in temperature-detection device helps minimize overheating, improving patient safety.
- **Stable:** Minimizes heat loss by maintaining a uniform temperature.

Hall-Effect Magnetic Position Sensors in Sleep Apnea Machines

SS400 Series

The Hall-effect magnetic position sensor is designed to provide enhanced output accuracy for smooth motor control that reduces noise and vibration in potential applications that include sleep apnea machine motor assembly fan systems. Its small size allows for design into many compact, automated, lower-cost assemblies. A thermally-balanced integrated circuit that is accurate over a full temperature range is designed to provide proper fan functionality.

Benefits to Customer

- **Accurate:** Enhanced accuracy and linearity over-span of 0~5 V output enables an extended sensing range.
- **Circuit protection:** Reverse voltage and polarity protection provides circuit protection.
- **Cost-effective:** Small sensor size allows for compact designs and automated, lower-cost assemblies.

- **Effective:** Thermally-balanced integrated circuit that is accurate over the full temperature range enhances proper fan function.
- **Energy-efficient:** Low power consumption enhances energy efficiency.
- **Quiet:** Industry-leading sensor output accuracy for smooth motor control enables low audible noise and reduces motor vibration.



SS400 Series

Humidity Sensors in Sleep Apnea Machines

HIH-4000 Series, HIH-4020/4021 Series, HIH-4030/4031 Series, HIH-5030/5031 Series, HCH-1000 Series

Humidity sensors monitor the amount of humidified air with accurate dew-point and absolute humidity/moisture measurement to provide a desired amount of air moisture to the patient, enhancing patient comfort to help provide uninterrupted sleep. Used in all three types of PAP machines.

Benefits to Customer

- **Accurate:** Enhanced stability, accuracy and response time over the entire humidity range of 0~100% RH supports demanding system performance requirements, even in many condensing environments.
- **Cost-effective:** Surface mount device (SMD) packaging on tape and reel allows for use in automated, high-volume, lower-cost pick-and-place manufacturing.
- **Durable:** Multi-layer construction and a hydrophobic filter provides enhanced resistance to condensation and contaminants.

- **Flexible:** Its small, space-saving housing profile allows for application flexibility. Its low current draw allows for use in low-current-drain, battery-operated systems.



Pressure Sensors in Sleep Apnea Machines

TruStability™ (HSC Series, SSC Series) Silicon Pressure Sensors

Honeywell's TruStability™ silicon pressure sensors monitor the pressure of air that is delivered to the patient in a variety of potential applications, including all three types of Positive Air Pressure (PAP) machines.

Benefits to Customer

- **Accurate:** TruStability™ sensors' exceptional accuracy is a result of leading-edge technology, precise manufacturing processes and temperature compensation and calibration. TruStability™ sensors have two levels of accuracy: the standard accuracy SSC Series offers $\pm 2\%$ total error band, and the HSC Series offers $\pm 1\%$ total error band, better than most competitive products.
- **Efficient:** The customer can monitor pressure within the specified range and adjust as needed, helping to prevent the airway from temporarily collapsing, improving the patient's ability to sleep and enhancing the efficacy of treatment.

- **Reliable:** Enhanced quality and reliability (<100 ppm) provides enhanced reliability in many demanding operations.
- **Sensitive:** Customized and calibrated to the customer's desired pressure range, providing enhanced sensitivity.
- **Stable:** Stability is a measure of how little the output signal of the pressure sensor will change from measurement to measurement. The long-term stability of Honeywell's TruStability™ sensors is the best in the industry.



Thermistors and Pre-Packaged Temperature Probes in Sleep Apnea Machines

192 Series and 194 Series Thermistor Temperature Sensors; 500 Series Pre-Packaged Temperature Probes

Air from sleep apnea machines that is warm and moist helps to provide the patient with a comfortable breathing situation and may reduce sore throats caused by breathing cold, dry air. As such, the temperature of the air delivery system is often monitored and controlled to provide an air stream at a desired level of warmth. Temperature sensors are installed directly into the air stream and are designed to monitor the air temperature.

Benefits to Customer

192 Series, 194 Series Thermistor Temperature Sensors

- Accurate and stable
- **Cost-effective:** Resistance temperature matched interchangeable units designed to provide cost savings by eliminating need for individual resistance temperature calibration and standardization of circuit components.
- **Simple:** Designed to simplify design and replacement in temperature measurement, indication, control and compensation of ambient temperature effects on a variety of integrated circuits and other semiconductor devices.
- **Small:** Small size often eases use in confined spaces.

500 Series Pre-Packaged Probes

- **Accurate:** Directs thermal or fluid flow evenly across thermistors for accurate temperature sensing.
- **Effective design:** Protects the thermistors against damage in use or handling.
- **Flexible:** Wide operating temperature range [60°C to 300°C/ -76 °F to 572 °F] provides application flexibility. Wide selection of housing, resistance and termination options provides application flexibility. Housing material ranges from all plastic to all metal, and accommodates air/gas, fluid immersion or surface sensing requirements.

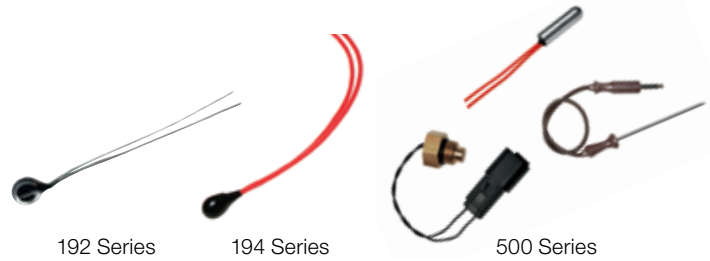

Sleep Apnea Machine Block Diagram

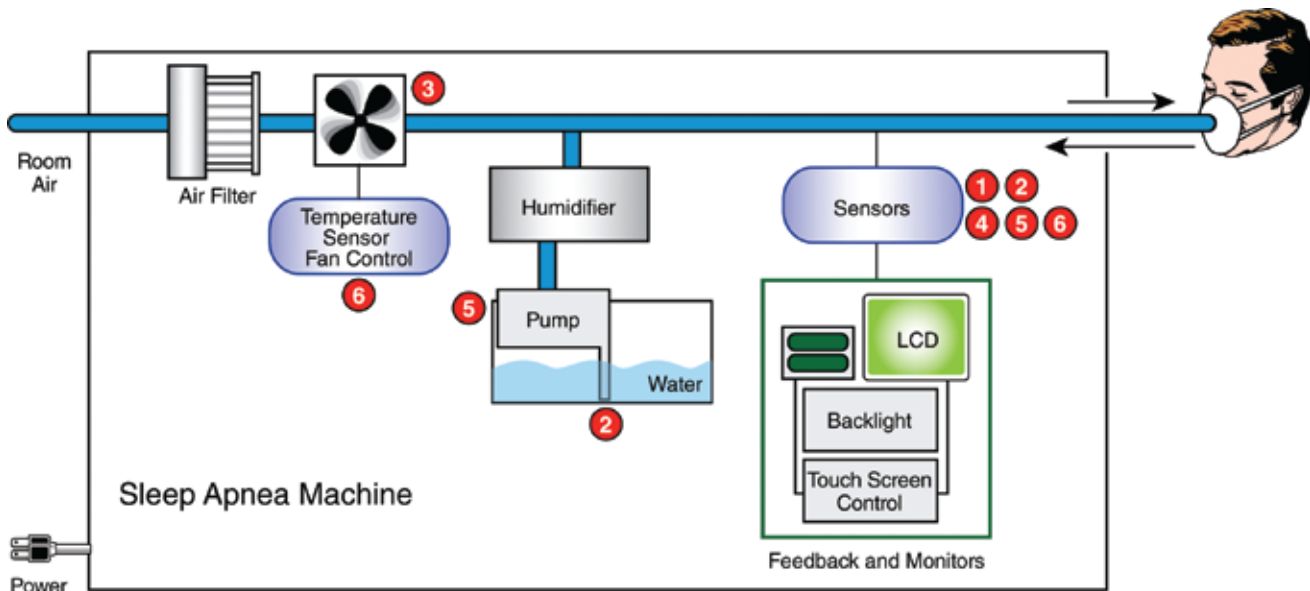

- 1 Airflow Sensors***
AWM90000 Series (AWM92100V),
AWM700 Series (AWM720P1)
- 2 Flexible Heaters**
A3100 Series, A3200 Series, A3400 Series,
C3100 Series, C3200 Series, C3400 Series
- 3 1st Level Hall-effect Magnetic Position Sensors**
SS400 Series

- 4 Humidity Sensors**
HIH-4000 Series, HIH-4020/4021 Series,
HIH-4030/4031 Series,
HIH-5030/5031 Series,
HCH-1000 Series
- 5 Pressure Sensors**
TruStability™ Silicon Pressure Sensors
(HSC Series, SSC Series)
- 6 Temperature Sensors**
192 Series, 194 Series Thermistors
500 Series Pre-packaged Temperature Probes

* Typically there is only one airflow sensor per machine. Some customers place it before the blower and some after the blower.



Respiratory: Ventilators

A ventilator is designed to move a mixture of air and oxygen into and out of a patient's lungs to either assist in breathing or, in some cases, do the mechanical breathing for a patient who is breathing insufficiently or is physically unable to breathe.

Sensor Solutions for Ventilators

- Airflow Sensors**
- Flexible Heaters**
- Hall-Effect Magnetic Position Sensors**
- Humidity Sensors**
- Pressure Sensors**
- Thermistors**

Airflow Sensors in Ventilators

AWM700 Series (AWM720P1), AWM5000 Series (AWM5104VN, AWM43300V, AWM3100V)

The AWM700 Series is designed to measure the flow of air, oxygen and nitrous oxide so that the desired mixture, as set by the doctor, is delivered to the patient. The total mixture that is delivered to the patient is also measured and displayed on the ventilator's panel. The AWM5000 Series may also be used; however, these are lower flow devices and may require a customer created bypass.

Benefits to Customer

- **Eases patient's breathing:** Lowest pressure drop in the industry (to 0.2 cm H₂O at 200 SLPM) provides lower flow resistance, easing breathing.
- **Improves patient comfort:** Enhanced sensitivity (the ability to detect ultra-low flow levels at 0.1 cubic centimeters) allows the sensor to detect when the patient exhales, sending a signal to reduce airflow which eases the patient's exhalation and improves patient comfort.

- **Reliable:** Enhanced quality and reliability (<100 ppm) and optional manifold mounting capability can reduce downtime in demanding operations.



AWM700 Series



AWM5000 Series

Flexible Heaters in Ventilators

A3100 Series, A3200 Series, A3400 Series, C3100 Series, C3200 Series, C3400 Series

A flexible heater is often required to vaporize water so that a comfortable breathing environment can be provided to the patient. There are other ways of generating water vapor, such as misting valves, but using heat ensures a uniform, warm and moist breathing experience most preferred by patients. The heat is generally controlled by an onboard negative temperature coefficient (NTC) thermistor offering variable air temperature that, depending on the OEM, can adjust the vapor/air temperature to improve patient comfort.

requirements.

- **Eases patient's comfort:** Integration of mounting and sensing components allows for the desired vaporization of water, enhancing patient comfort.
- **Eases system qualification:** Meets regulatory requirements, easing system qualification.
- **Flexible:** Numerous configurations (e.g., flat, molded-to-shape, spiral wrap, transparent, composite and high-temperature), a variety of manufacturing materials (e.g., silicone and other flexible dielectric components) and various watt densities (e.g., single, multiple or variable) increase application flexibility.

- **Safe:** Built-in temperature-detection device helps minimize overheating, improving patient safety.
- **Stable:** Minimizes heat loss by maintaining a uniform temperature.



3100 Series



3200 Series



3400 Series

Benefits to Customer

- **Customizable:** Capability to quickly customize flexible heater building block technology to meet application

Hall-Effect Magnetic Position Sensors in Ventilators

SS400 Series

The Hall-effect magnetic position sensor is designed to provide enhanced output accuracy for smooth motor control that reduces noise and vibration in many potential applications, including ventilator motor assembly fan systems. Its small size often allows for design into many compact, automated, lower-cost assemblies. A thermally-balanced integrated circuit that is accurate over a full temperature range is designed to provide proper fan functionality.

Benefits to Customer

- **Accurate:** Enhanced accuracy and linearity over-span of 0~5 V output enables an extended sensing range.
- **Circuit protection:** Reverse voltage/polarity protection provides circuit protection.
- **Cost-effective:** Small sensor size allows for compact designs and automated, lower-cost assemblies.
- **Effective:** Thermally-balanced integrated circuit that is accurate over the full temperature range enhances proper fan function.

- **Energy-efficient:** Low power consumption enhances energy efficiency.
- **Quiet:** Industry-leading sensor output accuracy for smooth motor control enables low audible noise and reduces motor vibration.



SS400 Series

Humidity Sensors in Ventilators

HIH-4000 Series, HIH-4020/4021 Series, HIH-4030 Series, HIH-4602 Series, HIH-5030/5031 Series, HCH-1000 Series

Honeywell's humidity sensors help deliver warm and moist air, which often enhances patient comfort. When introducing moisture into the air stream of a ventilator, it must be monitored and controlled. Honeywell's humidity sensors are installed either directly into the air stream or in a parallel branch. The sensor is coupled to a microcontroller designed to measure the humidity of the air stream and to signal the controller that the desired level of moisture is present.

Benefits to Customer

- **Accurate:** Enhanced stability, accuracy and response time over the entire humidity range of 0~100% RH supports demanding system performance requirements, even in many condensing environments.
- **Cost-effective:** Surface mount device (SMD) packaging on tape and reel allows for use in automated, high-volume, lower-cost pick-and-place manufacturing.

- **Durable:** Multi-layer construction and a hydrophobic filter provides enhanced resistance to condensation and contaminants.
- **Flexible:** Small, space-saving housing profile allows for application flexibility; utilizing a low current draw allows for use in low-current-drain, battery-operated systems.



HIH-4000 Series

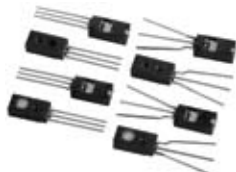

HIH-4020/4021 Series



HIH-4030



HIH-4602 Series



HIH-5030/5031 Series



HCH-1000 Series

Pressure Sensors in Ventilators

Silicon: TruStability™ (HSC Series, SSC Series), ASDX Series, CPC Series (CPCL10GFC), SDX Series (SDX010IND4)
Stainless Steel Media Isolated: MLH Series, 19mm Series, SPT Series

Honeywell's TruStability™ and ASDX Series silicon pressure sensors are designed to measure air and oxygen pressure so that the pressure doesn't exceed a desired level. The CPC Series and the SDX Series may also be used with a customer-provided amplifier or ASIC-based solution for a signal conditioned output. The MLH Series, 19 mm Series and SPT Series stainless steel media isolated pressure sensors are designed to provide a sensing solution when high pressure, steel pressure port interface and/or corrosive media are used. A male threaded pressure port and stainless steel wetted surfaces provide an air and oxygen inlet.

Benefits to Customer

- **Accurate:** Enhances patient safety by measuring volume and mixture of gases to deliver the mixture at a desired pressure and flow.
 - TruStability™ sensors' exceptional

accuracy is a result of leading-edge technology, precise manufacturing processes and temperature compensation and calibration.

TruStability™ sensors have two levels of accuracy: the standard accuracy SSC Series offers $\pm 2\%$ total error band, and the HSC Series offers $\pm 1\%$ total error band, better than most competitive products.

- ASDX Series offers accuracy of $\pm 2\%$.
- MLH Series' accuracy depends upon the pressure range: above 300 psi 0.25% FSS; below 300 psi 0.5% FSS; 19 mm Series offers 0.25% FSS; SPT Series offers 0.25% FSS.

- **Compatible:** Wetted materials or media isolated packaging (materials resistant to certain contaminants or media) offer compatibility with many harsh environments and resistance to certain contaminants.
- **Easy to design in:** Customization of

pressure ranges, connections, calibration and temperature compensation minimize customer's design-in effort.

- **Easy to use:** Small package with integrated signal conditioning reduces the number of components needed to implement the sensor, enabling size reduction of the end product.
- **Safe:** Enhanced accuracy, sensitivity and stability with minimal drift over time and temperature enhances patient safety and therapy effectiveness by sensing when patient is breathing on own to wean off the device.
- **Stable:** Stability is a measure of how little the output signal of the pressure sensor will change from measurement to measurement. The long-term stability of Honeywell's TruStability™ sensors is the best in the industry.



TruStability™ HSC Series, SSC Series



ASDX Series



CPC Series



SDX Series



MLH Series



19 mm Series



SPT Series

Thermistors in Ventilators

192 Series, 194 Series

Air from ventilators that is warm and moist helps to provide the patient with a comfortable breathing situation and may reduce sore throats caused by breathing cold, dry air. As such, the temperature of the air delivery system is often monitored and controlled to provide an air stream at a desired level of warmth. Discrete thermistor temperature sensors are installed directly into the air stream and are designed to monitor the air temperature. The sensor is coupled to a microcontroller designed to measure air stream temperature and interact with the

controller which controls and regulates the temperature of the air stream. Honeywell offers several types of configurations.

The packaged sensors are available as discrete components for customer-built assemblies, or Honeywell can provide a full assembly solution that the customer may simply pigtail into the system.

Benefits to Customer

- **Cost-effective:** Resistance temperature curve interchangeability designed to offer standardization of circuit components and simplification of design/replacement enhances cost-effectiveness.

- **Flexible:** Bare leads (192 Series) or insulated leads (194 Series) are designed to provide application flexibility.

- **Small:** Small size often eases use in confined spaces.



192 Series



194 Series

Ventilator Block Diagram

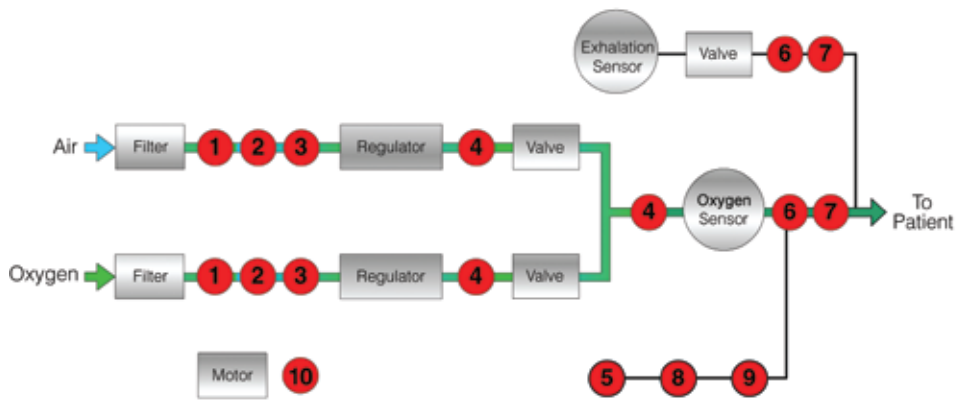

- 1 **Stainless Steel Media Isolated Pressure Sensors**
MLH Series
- 2 **Stainless Steel Media Isolated Pressure Sensors**
19 mm Series
- 3 **Stainless Steel Media Isolated Pressure Sensors**
SPT Series
- 4 **Airflow Sensors**
AWM700 Series
AWM720P1
- 5 **Discrete Thermistor Temperature Sensors**
192 or 194 Series
- 6 **Low Pressure Silicon Pressure Sensors**
TruStability™
(HSC Series, SSC Series)
- 7 **Ultra-Low Pressure Silicon Pressure Sensors**
ASDX Series
- 8 **Flexible Heaters**
A3100, C3100, A3200,
C3200, A3400 or C3400 Series
Custom Configuration
- 9 **Humidity Sensors**
HIH or HCH Series
- 10 **1st Level Hall-Effect Magnetic Position Sensors**
SS400 Series





Kidney Dialysis Machines

Kidney dialysis machine treatments replace some kidney functions by removing waste and fluid from the bloodstream via diffusion and osmosis of solutes and fluid across a semi-permeable dialysis membrane. Blood in one compartment is pumped along one side of the membrane while a dialysate (a crystalloid solution that acts as a sponge for impurities) is pumped along the other side, in a separate compartment, in the opposite direction. Ultra filtration occurs by increasing the hydrostatic pressure across

the membrane by applying a negative pressure to the dialysate compartment of the dialyzer. This pressure gradient causes water and dissolved solutes to move from the blood to the dialysate. The cleansed blood returns via the circuit back to the body. Honeywell manufactures many sensors that may be used in kidney dialysis machines. They provide presence and absence detection, and pressure, flow and temperature measurement.

Sensor Solutions for Kidney Dialysis Machines

- Flexible Heaters**
- Force Sensors**
- Hall-Effect Magnetic Position Sensors**
- Infrared Sensors**
- Pressure Sensors**
- Thermistors**

Flexible Heaters in Kidney Dialysis Machines

A3100 Series, A3200 Series, A3400 Series, C3100 Series, C3200 Series, C3400 Series

Honeywell's flexible heaters are designed to provide controlled heat for warming blood or dialysate to body temperature prior to re-entry into the body. This may be accomplished by either heat exchange (constant temperature bath) or direct heat through warming plates. These flexible heaters are custom-designed to customer requirements. Other components, such as NTC thermistors, RTDs or solid state temperature sensors, may be added for temperature monitoring and control.

Benefits to Customer

- **Customizable:** Capability to quickly customize flexible heater building block

technology to meet custom application requirements.

- **Eases system qualification:** Meets regulatory requirements, easing system qualification.
- **Flexible:** Numerous configurations (e.g., flat, molded-to-shape, spiral wrap, transparent, composite and high-temperature), a variety of manufacturing materials (e.g., silicone and other flexible dielectric components) and various watt densities (e.g., single, multiple or variable) increase application flexibility.
- **Safe:** Built-in temperature-detection device helps minimize overheating, improving patient safety.

- **Stable:** Minimizes heat loss by maintaining a uniform temperature.



3100 Series



3200 Series



3400 Series

Force Sensors in Kidney Dialysis Machines

1865 Series, FS01 Series, FS03 Series

Honeywell's 1865 Series and FS01/FS03 Series force sensors may be used to detect the presence or absence of a fresh dialysate cartridge before the dialysis machine can be used. These sensors are used in a non-invasive manner and require no disinfection or sterilization before reuse. Other potential uses for Honeywell's force sensors include monitoring the flexible tubing pressure of the dialysate to detect whether the pressure exceeds a specified

level, and monitoring the weight of the dialysate to detect whether there is a sufficient amount of dialysate in the fresh dialysate cartridge.

Benefits to Customer

- **Reliable:** Enhanced quality and reliability (<100 ppm).
- **Sensitive:** Enhanced sensitivity to force changes enables early detection of occlusion, enhancing patient safety.

- **Stable:** Ability to detect occlusion accurately over time provides enhanced stability and low drift.



Hall-Effect Magnetic Position Sensors in Kidney Dialysis Machines

SS400 Series

The Hall-effect magnetic position sensor is designed to provide reliable, accurate output for smooth motor control that reduces noise and vibration in the machine's motor assembly and improves its efficiency. Its solid state reliability often reduces repair and maintenance costs, and its small size allows for design into many compact, automated, lower-cost assemblies. A thermally-balanced integrated circuit provides consistent operation over the full temperature range.

Benefits to Customer

- **Accurate:** For linear displacement and current sensing, analog Hall-effect sensors provide accurate and linear output over-span of 0~5 V, enabling an extended sensing range.
- **Cost-effective:** Small sensor size allows for compact designs and automated, lower-cost assemblies and minimizes replacement costs.
- **Energy-efficient:** Hall-effect sensors

consume little energy and help improve motor efficiency.

- **Quiet:** Reliable, accurate sensor output for smooth motor control enables low audible noise, and reduces motor vibration.



Infrared Sensors in Kidney Dialysis Machines

HOA088X Series, HOA698X Series

Honeywell's infrared sensors are designed to be used with an encoder wheel on the pump shaft to count shaft rotation. They contain an infrared emitter and a photo detector that are mounted facing each other inside a plastic housing. Detection occurs when an opaque object passes through the package slot, interrupting the infrared path.

Benefits to Customer

- **Enables maximum position resolution:** Lead wires provide alternate electrical connection when PC board mounting is not possible, often ideal for use in potential applications in which maximum position resolution is desired.

- **Operates in contaminated environments:** Infrared transmissive polysulfone housing features smooth optical faces without external aperture openings, desirable when aperture blockage from airborne contaminants is a possibility.
- **Reliable:** Reliability is enhanced by the following: all solid-state design; low power consumption; no moving parts; built-in strain relief for maximum wire attachment strength; PC board mount is available.

- **Robust:** Variety of package styles, optical aperture sizes and mounting options; analog and digital outputs (digital output options are 10K pull-up, open collector or totem-pole with inverting or non-inverting options).



HOA088X Series



HOA698X Series

Pressure Sensors in Kidney Dialysis Machines

Silicon: TruStability™ (HSC Series, SSC Series), 26PC Flow-Through Series (26PCFEP5G40)

Stainless Steel Media Isolated: 13 mm Series, 19 mm Series, SPT Series

Honeywell's TruStability™ and 26PC Series Flow-Through silicon pressure sensors are designed to provide enhanced reliability and may be used to obtain a direct, in-line continuous dialysate and venous pressure measurement in the dialysis membrane without interrupting flow. The easy-to-sterilize package eliminates the need for an additional pressure tap and/or manifold, minimizing the unused space in the flow measurement path, which helps to prevent bacteria contamination and simplifies sterilization. The 13 mm Series, 19 mm Series and SPT Series media isolated pressure sensors, when located in a fresh dialysate cartridge, may be used to monitor pressure in the flexible tubing that carries blood or dialysate to provide continuous feedback of line pressures and pump control. These sensors may also be used to perform the same function as the 26PC Flow-Through Series in the dialysis membrane.

Benefits to Customer

- **Accurate:** Provides stable performance with low drift over time, allowing accurate pressure monitoring of fluid and blood flow to help maintain the pressure in the desired range, improving treatment efficiency and reducing the time it takes to remove fluid from the peritoneum. TruStability™ sensors' exceptional accuracy is a result of leading-edge technology,

precise manufacturing processes and temperature compensation and calibration. TruStability™ sensors have two levels of accuracy: the standard accuracy SSC Series offers $\pm 2\%$ total error band, and the HSC Series offers $\pm 1\%$ total error band, better than most competitive products. Honeywell's 26PC Flow-Through Series offers $\pm 2\%$; 13 mm Series, 19 mm Series and SPT Series offer 0.25% FSS.

- **Easy to design in:** Customization with desired pressure ranges, connections, calibration and temperature compensation minimizes customer's design-in effort.
- **Extended life:** Product availability throughout the customer's product lifecycle minimizes the need to repeat the design-in process and requalifying/resubmitting for regulatory approval.
- **Small:** Small package reduces the number of components needed to implement the sensor, enabling reduction in size and weight.
- **Stable:** Stability is a measure of how little the output signal of the pressure sensor will change from measurement to measurement. The long-term stability of Honeywell's TruStability™ sensors is the best in the industry.



TruStability™ HSC Series,
SSC Series



26PC Flow-Through
Series



13 mm Series



19 mm Series



SPT Series

Thermistors in Kidney Dialysis Machines

192 Series, 194 Series

Temperature directly affects the permeation rate across the dialysis membrane. The 192 and 194 Series discrete thermistor temperature sensors provide temperature measurement for enhanced control of this variable. The sensor is coupled to a microcontroller designed to monitor the temperature of the operation and to interact with the controller to help regulate the temperature of the system. Honeywell offers several configurations. These packaged sensors are available as discrete components for custom-built assemblies, as well as full assembly solutions that the customer may simply pigtail into the system.

Benefits to Customer

- **Cost-effective:** Resistance temperature curve interchangeability designed to offer standardization of circuit components and simplification of design/replacement enhances cost-effectiveness.

- **Flexible:** Bare leads (192 Series) or insulated leads (194 Series) are designed to provide application flexibility.
- **Small:** Small size often eases use in confined spaces.



192 Series



194 Series

Kidney Dialysis Machine Block Diagram

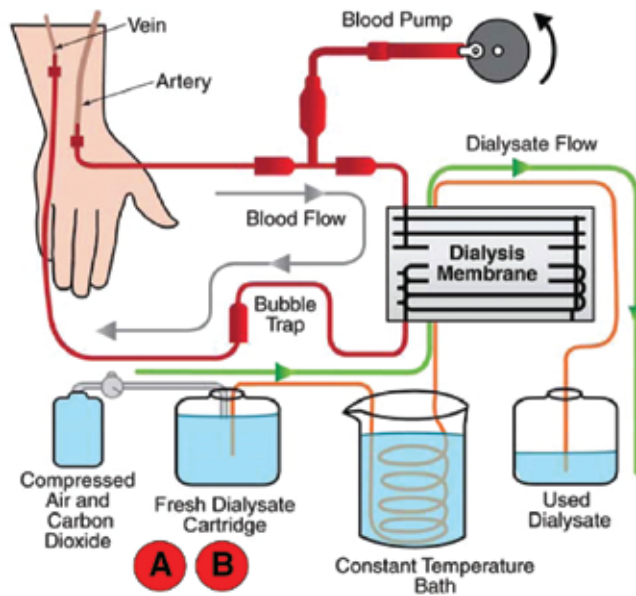

- A Force Sensors**
1865 Series
FS01/FS03 Series
- B Stainless Steel Media Isolated Pressure Sensors**
13 mm Series, 19 mm Series,
SPT Series

Dialysis Membrane Detail

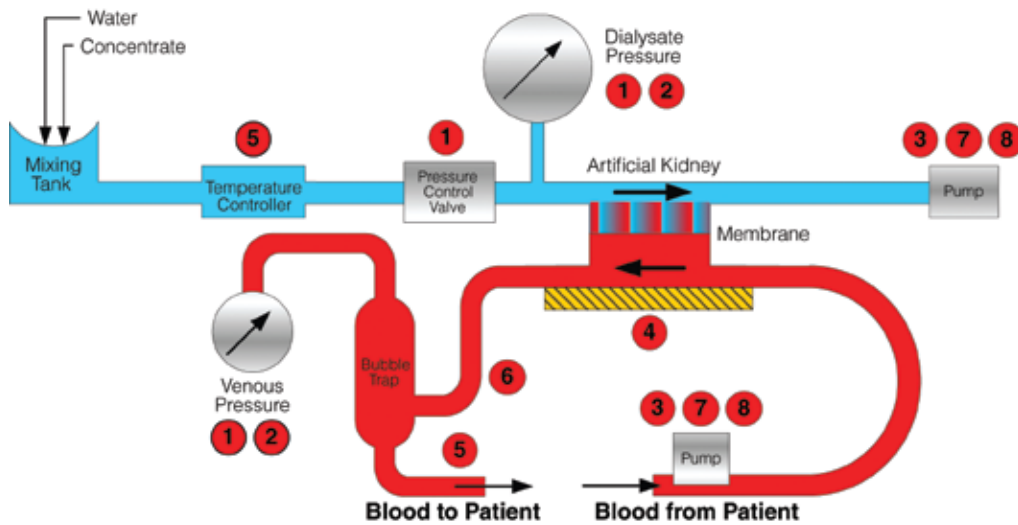

- 1 Low Pressure Silicon Pressure Sensors**
TruStability™ (HSC Series, SSC Series),
26PC Flow Through Series
26PCEP5G40G
- 2 Stainless Steel Media Isolated Pressure Sensors**
13 mm Series, 19 mm Series, SPT Series
- 3 1st Level Hall-Effect Magnetic Sensors**
SS400 Series
- 4 Flexible Heaters**
A3100, C3100, A3200, C3200,
A3400 or C3400
Custom Configuration
- 5 Discrete Thermistor Temperature Sensors**
192 or 194 Series
- 6 Force Sensors**
FS01/FS03 Series
- 7 Transmissive Infrared Sensors**
HOA088X
- 8 Optoschmitt (Transmissive) Infrared Sensors**
HOA698X



Infusion, Insulin or Syringe Pumps



An infusion, insulin or syringe pump—typically a screw pump that pushes on a syringe or cartridge—is used to deliver small amounts of medication to a patient intravenously.

Sensor Solutions for Infusion, Insulin or Syringe Pumps

- Flexible Heaters
- Force Sensors
- Hall-Effect Magnetic Position Sensors
- Infrared Sensors
- Pressure Sensors

Flexible Heaters in Infusion Pumps

A3400 Series, C3400 Series

Honeywell's flexible heaters are designed to conform to the infusion pump's surface that requires heating. They are capable of maintaining specific temperatures at desired levels.

Benefits to Customer

- **Application flexibility:** Numerous configurations (e.g., flat, molded-to-shape, spiral wrap, transparent, composite and high-temperature), a variety of manufacturing materials (e.g., silicone and other flexible dielectric components) and various watt densities (e.g., single, multiple or variable) increase application flexibility.
- **Customizable:** Capability to quickly customize flexible heater building block technology meets custom application requirements.

- **Eases system qualification:** Meets regulatory requirements, easing system qualification.
- **Improves patient's safety:** Built-in temperature-detection device helps minimize overheating, improving patient safety.
- **Stable:** Minimizes heat loss by maintaining a uniform temperature.



3400 Series

Force Sensors in Infusion, Insulin Pumps and Syringe Pumps

FSS Series, FSS-SMT Series, FSG Series and 1865 Series (Infusion Pumps); FSS Series and FSS-SMT Series (Insulin Pumps)

Honeywell's force sensors provide an occlusion detector to ensure there isn't a blockage in the infusion or insulin pump's tube that delivers the medication to the patient. If the tube becomes blocked, the force sensor alerts the patient, nurse or doctor via an audible alarm that the therapy isn't being delivered.

Benefits to Customer

- **Easy to use:** Sensor is external to the tubing (media isolated), minimizing the need for the tubing to be sterilized or re-sterilized after each use.
- **Portable:** Sensor's small size and low power consumption improves the patient's quality of life due to the increased portability of the end product and longer battery life (FSS Series).

- **Reliable:** Enhanced quality and reliability (<100 ppm) provides enhanced reliability in many demanding operations.
- **Sensitive:** Enhanced sensitivity to force changes enables early detection of occlusion, enhancing patient safety.
- **Stable:** Ability to detect occlusion accurately over time provides enhanced stability and low drift.



Hall-Effect Magnetic Position Sensors in Infusion and Insulin Pumps

SS400 Series

The Hall-effect magnetic position sensor is designed to provide reliable, accurate output for smooth motor control that reduces noise and vibration in the pump's motor assembly and improves its efficiency. Its solid state reliability often reduces repair and maintenance costs, and its small size allows for design into many compact, automated, lower-cost assemblies. A thermally-balanced integrated circuit provides consistent operation over the full temperature range.

Benefits to Customer

- **Accurate:** For linear displacement and current sensing, analog Hall-effect sensors provide accurate and linear output over-span of 0-5 V, enabling an extended sensing range.

- **Cost-effective:** Small sensor size allows for compact designs and automated, lower-cost assemblies and minimizes replacement costs.
- **Energy-efficient:** Hall-effect sensors consume little energy and help improve motor efficiency.
- **Quiet:** Reliable, accurate sensor output for smooth motor control enables low audible noise, and reduces motor vibration.



Infrared Sensors in Infusion, Insulin and Syringe Pumps

HOA088X Series, HOA698X Series

Honeywell's infrared sensors are designed to be used with an encoder wheel on the pump shaft to count shaft rotation. They contain an infrared emitter and a photo detector that are mounted facing each other inside a plastic housing. Detection occurs when an opaque object passes through the package slot, interrupting the infrared path.

Benefits to Customer

- **Enables maximum position resolution:** Lead wires provide alternate electrical connection when PC board mounting is not possible, often ideal for use in potential applications in which maximum position resolution is desired.
- **Operates in contaminated environments:** Infrared transmissive polysulfone housing features smooth optical faces without external aperture openings, often desirable when aperture blockage from airborne contaminants is a possibility.

- **Reliable:** Reliability is enhanced by the following: all solid-state design; low power consumption; no moving parts; built-in strain relief for maximum wire attachment strength; PC board mount is available.
- **Robust:** Variety of package styles, optical aperture sizes and mounting options; analog and digital outputs (digital output options are 10K pull-up, open collector or totem-pole with inverting or non-inverting options).



Pressure Sensors in Infusion, Insulin and Syringe Pumps

TruStability™ Silicon Pressure Sensors (HSC Series, SSC Series)

Honeywell's TruStability™ silicon pressure sensors may be used to monitor and control the flow of fluid.

Benefits to Customer

- **Accurate:** Provides stable performance with low drift over time, allowing accurate pressure monitoring of fluid flow to help maintain the pressure in the desired range, improving treatment efficiency. TruStability™ sensors' exceptional accuracy is a result of leading-edge technology, precise manufacturing processes and temperature compensation and calibration. TruStability™ sensors have two levels of accuracy: the standard accuracy SSC Series offers $\pm 2\%$ total error band, and the HSC Series offers $\pm 1\%$ total error band, better than most competitive products.
- **Easy to design in:** Customization with desired pressure ranges, connections, calibration and temperature compensation minimizes customer's design-in effort.

- **Stable:** Stability is a measure of how little the output signal of the pressure sensor will change from measurement to measurement. The long-term stability of Honeywell's TruStability™ sensors is the best in the industry.



TruStability™ HSC Series,
SSC Series

Infusion Pump Block Diagram

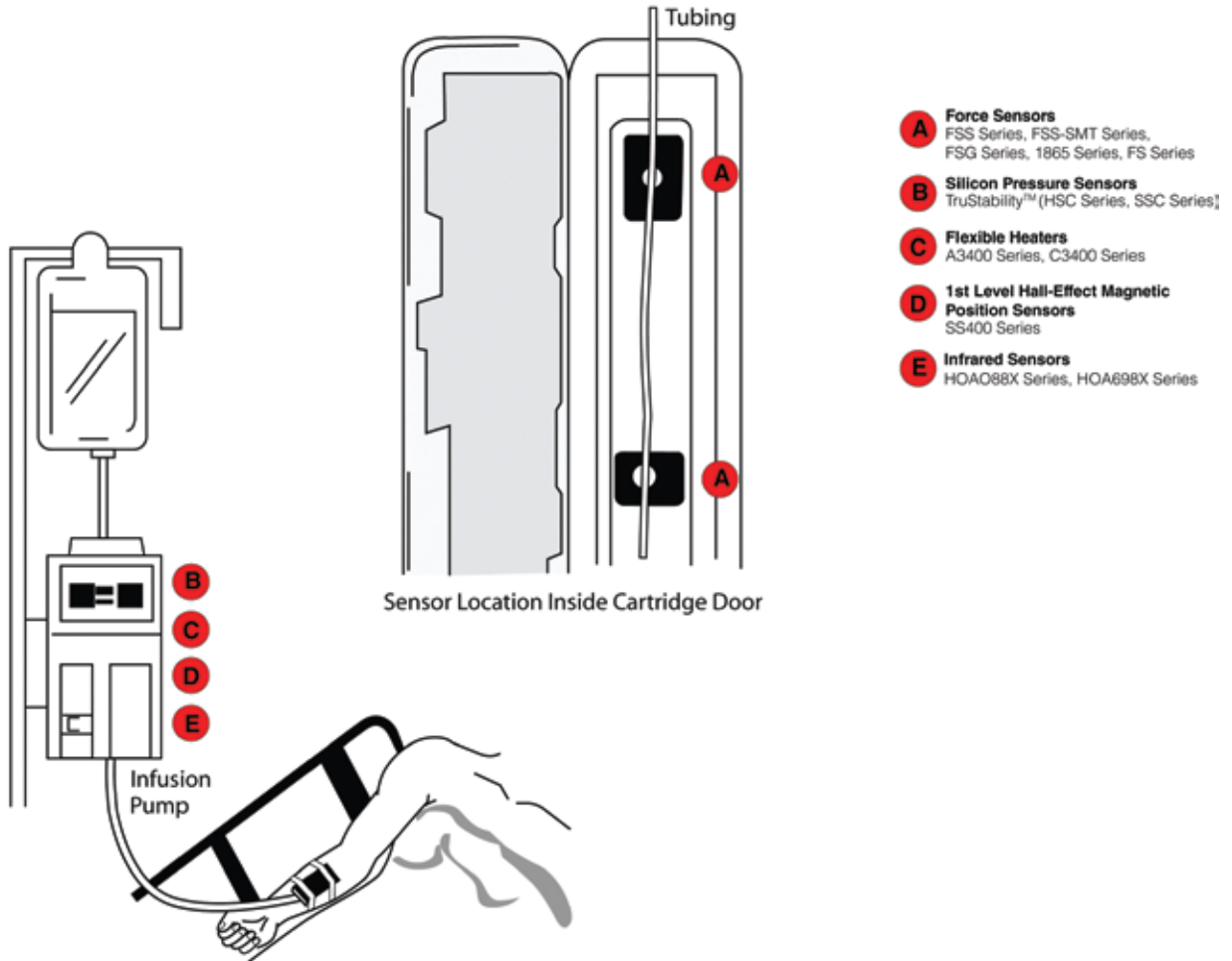



Hospital Diagnostics

Honeywell offers a broad sensor portfolio for a variety of hospital diagnostic applications, including blood analyzers, hematology analyzers, immunoassay analyzers, clinical chemistry analyzers, mass spectrometers, chromatography (gas, liquid, HPLC) and lab automation systems. Potential sensor applications include airflow sensors to regulate flow rate in gas chromatography, force and position sensors to control lab automation robotics, pressure sensors used in the pump system to inject samples, speed sensors to control the spinning of the centrifuge and thermistors to control sample and chamber temperature.

Sensor Solutions for Hospital Diagnostics

- Airflow Sensors**
- Infrared Sensors**
- Pressure Sensors**
- Thermistors**

Airflow Sensors in Gas Chromatography

AWM40000 Series

Medical gas chromatography requires precise and accurate monitoring and regulation of the flow of gases. Honeywell's airflow sensor's ceramic flow tube is designed to minimize outgassing with enhanced accuracy and reliability.

Benefits to Customer

- **Accurate:** Provides accurate control of delivery of carrier gases at required flow rate with enhanced sensitivity (the ability to detect ultra-low flow levels at 0.1 cubic centimeters).
- **Eases implementation:** Provides optional manifold mounting to reduce customers' effort of designing and implementing the sensors.

- **Minimizes risk of contamination:** Ceramic flow tube assembly with no outgassing minimizes risk of contamination.
- **Reliable:** Reduces downtime in many demanding operations with enhanced quality and reliability (<100 ppm).
- **Stable:** Provides accurate control of flow rate over time for consistent, stable, repeatable test results with enhanced stability.



AWM40000 Series

Infrared Sensors in Hematology Analyzers

HOA Series, HOA088X Series, HOA187X Series

In hematology analyzers, Honeywell's infrared sensors may be used with an encoder wheel on the pump shaft to count shaft rotation. They are mounted facing each other. Detection occurs when an opaque object passes through the package slot, interrupting the infrared path.

Benefits to Customer

- **Enables maximum position resolution:** Lead wires provide alternate electrical connection when PC board mounting is not possible, often ideal for use in potential applications in which maximum position resolution is desired.

- **Operates in contaminated environments:** Infrared transmissive polysulfone housing features smooth optical faces without external aperture openings, often desirable when aperture blockage from airborne contaminants is a possibility.
- **Reliable:** Reliability is enhanced by the following: all solid-state design, low power consumption, no moving parts, built-in strain relief for maximum wire attachment strength. PC board mount is available.

- **Robust:** Variety of package styles, optical aperture sizes and mounting options; analog and digital outputs (digital output options are 10K pull-up, open collector or totem-pole with inverting or non-inverting options).



HOA088X Series



HOA187X Series

Pressure Sensors in Blood Analyzers

Silicon Sensors: TruStability™ (HSC Series, SSC Series), 26PC Series

Honeywell's TruStability™ and 26PC Series silicon pressure sensors are used to regulate the pressure in the pump system to draw and transport the blood samples.

Benefits to Customer

- **Accurate:** TruStability™ sensors' exceptional accuracy is a result of leading-edge technology, precise manufacturing processes and temperature compensation and calibration. TruStability™ sensors have two levels of accuracy: the standard accuracy SSC Series offers $\pm 2\%$ total error band, and the HSC Series offers $\pm 1\%$ total error band, better than most competitive products.

- **Contaminant and corrosion resistant:** Ability to work with potential contaminants due to the wet/wet compatibility and a flow path with minimal dead space (26PC Series).
- **Product availability:** The sensor is available throughout the customers' product life cycle, so there is little concern for resubmission and approval to replace the sensors.
- **Reliable:** Minimizes downtime and improves throughput with enhanced quality and reliability (<100 ppm) (26PC Series).
- **Stable:** Enhanced accuracy in pressure monitoring to control the pumps and repeatable pressure, essential for the

spectrum analysis. Stability is a measure of how little the output signal of the pressure sensor will change from measurement to measurement. The long-term stability of Honeywell's TruStability™ sensors is the best in the industry.



TruStability™ HSC Series, SSC Series

Pressure Sensors in Gas Chromatography

Silicon Sensor: TruStability™ (HSC Series, SSC Series)

Honeywell's TruStability™ silicon pressure sensor is used to sense and control pressure of the gas stream to maintain a constant and precise flow.

Benefits to Customer

- **Accurate:** TruStability™ sensors' exceptional accuracy is a result of leading-edge technology, precise manufacturing processes and temperature compensation and calibration. TruStability™ sensors have

two levels of accuracy: the standard accuracy SSC Series offers $\pm 2\%$ total error band, and the HSC Series offers $\pm 1\%$ total error band, better than most competitive products.

- **Stable:** Enhanced accuracy in pressure monitoring to control the pumps and repeatable pressure, essential for the spectrum analysis. Stability is a measure of how little the output signal of the pressure sensor

will change from measurement to measurement. The long-term stability of Honeywell's TruStability™ sensors is the best in the industry.



TruStability™ HSC Series, SSC Series

Thermistors in Blood Analyzers

192 Series, 194 Series

Discrete thermistor temperature sensors are used to monitor the temperature of the chamber, the diffusion lamps and oil-cooled motor to prevent them from overheating. There is also a need to measure the temperature as close to the sample as possible to control the sample temperature. Honeywell offers several types of configurations. The packaged sensors are available as discrete components for customer-built

assemblies, or Honeywell can provide a full assembly solution that the customer may simply pigtail into the system.

Benefits to Customer

- **Application flexibility:** Bare leads (192 Series) or insulated leads (194 Series) are designed to provide application flexibility.
- **Cost-effective:** Resistance temperature curve interchangeability designed to offer standardization of circuit components

and simplification of design and/or replacement enhances cost-effectiveness.

- **Small:** Small size often eases use in confined spaces.

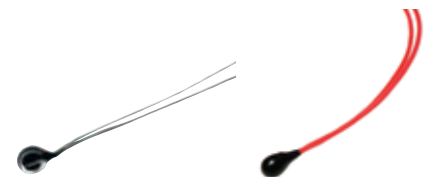

192 Series

194 Series





Patient Monitoring Systems

Patient monitors are used in clinical environments (e.g., operating rooms, emergency rooms, intensive care, critical units and, increasingly, patient homes) to monitor and display the patient's vital signs, including ECG, SpO₂ (saturation of peripheral oxygen), blood pressure, respiration and temperature. Patient monitors can be standalone or multi-parameter monitors. Honeywell sensors have been used in applications with blood pressure monitoring, glucose monitoring, respiratory monitoring and temperature monitoring.

Blood pressure monitoring may be measured through either an inserted pressure transducer or non-invasively through a blood pressure cuff (NIBP).

Glucose monitoring measures the glucose level in the interstitial fluid. Continuous glucose monitoring allows examination of how the blood glucose level reacts to insulin, exercise, food and other factors. Potential sensor applications for Honeywell sensors include the continuous glucose monitors used in critical care units, operating rooms or patient recovery, where pumps are used to draw blood and/or return the blood to the body. Sensors could also be used in selected handheld glucose monitors if pressure needs to be regulated when drawing blood.

Respiratory monitoring displays critical respiratory indices including capnography, which monitors the concentration or partial

pressure of CO₂ in the respiratory gases, and spirometers, which measure direct in- and out-flow. Temperature monitoring consists of the monitoring of patient temperature.

Sensor Solutions for Patient Monitoring

- Airflow Sensors**
- Pressure Sensors**
- Thermistors**

Airflow Sensors in Respiratory Monitoring

AWM90000 Series

Honeywell's airflow sensors monitor the patient's respiratory function.

Benefits to Customer

- **Improves measurement sensitivity and accuracy:** Enhanced sensitivity (the ability to detect ultra-low flow levels at 0.1 cubic centimeters) improves the accuracy of the airflow measurement.
- **Portable:** Small sensor package size allows system size reduction, improving portability.

- **Reliable:** Enhanced quality and more reliable performance (<100 ppm) can reduce downtime.



AWM90000 Series

Pressure Sensors in Blood Pressure Monitors

Silicon: TruStability™ (HSC Series, SSC Series), 20PC Series, CPC Series

Honeywell's silicon pressure sensors may be used in blood pressure monitors to measure blood pressure.

Honeywell's TruStability™, 20PC and CPC Series silicon pressure sensors may be used in blood pressure monitors. The CPC Series may also be used with a customer-provided amplifier or ASIC-based solution for a signal conditioned output.

Benefits to Customer

- **Accurate:** Accurate pressure monitoring in blood pressure monitors allows measurement of blood pressure with enhanced stability and minimal drift over time. Honeywell's TruStability™ sensors' exceptional accuracy is a result of leading-edge technology, precise manufacturing processes and temperature compensation and calibration. TruStability™ sensors have two levels of accuracy: the standard accuracy SSC Series offers

Pressure Sensors in Blood Glucose Monitoring

TruStability™ HSC Series, SSC Series, HPX Series

Honeywell's TruStability™ and HPX Series silicon pressure sensors are used to control the pumps used to draw the blood and return it to the patient in continuous glucose monitors used in critical care units. These pressure sensors meet the size requirements for selected handheld glucose meters with the need of pressure measurement of the glucose monitoring.

Benefits to Customer

- **Improves patient safety with best-in-class low drift:** Low drift in the pressure sensor allows accurate control of the pump pressure.
- **Accurate:** Accurate pressure monitoring in blood pressure monitors allows measurement of blood pressure with enhanced stability and minimal drift over time. Honeywell's TruStability™ sensors' exceptional accuracy is a result of leading-edge technology, precise manufacturing processes and temperature compensation and calibration. TruStability™ sensors have two levels of accuracy: the standard accuracy SSC Series offers

Thermistors in Thermometers or Temperature Monitoring in Patient Monitoring

192 Series, 194 Series

Honeywell's 192 Series and 194 Series discrete thermistor temperature sensors are used to monitor patient temperature. Honeywell offers several types of configurations. The packaged sensors are available as discrete components for customer-built assemblies, or Honeywell can provide a full assembly solution that the customer may simply pigtail into the system.

Benefits to Customer

- **Application flexibility:** Bare leads (192 Series) or insulated leads (194 Series) are designed to provide application flexibility.

$\pm 2\%$ total error band, and the HSC Series offers $\pm 1\%$ total error band, better than most competitive products.

- **Portability:** Small sensor size improves blood pressure monitor portability.
- **Stable:** Stability is a measure of how little the output signal of the pressure sensor will change from measurement to measurement. The long-term stability of Honeywell's TruStability™ sensors is the best in the industry.



$\pm 2\%$ total error band, and the HSC Series offers $\pm 1\%$ total error band, better than most competitive products.

- **Portability:** The small size of the HPX Series improves handheld glucose monitor portability.
- **Stable:** Stability is a measure of how little the output signal of the pressure sensor will change from measurement to measurement. The long-term stability of Honeywell's TruStability™ sensors is the best in the industry.



- **Cost-effective:** Resistance temperature curve interchangeability designed to offer standardization of circuit components and simplification of design/replacement enhances cost-effectiveness.
- **Small:** Small size often eases use in confined spaces.

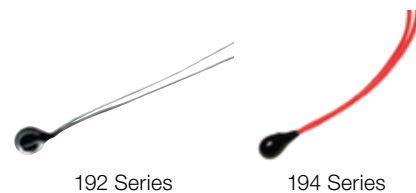



Hospital Hardware

Honeywell's sensors and switches have been used in a variety of hospital hardware (e.g., sterilizers, blood storage refrigerators, autoclaves, incubators, hospital beds, medication dispensing cabinets) to help minimize downtime, provide stable and repeatable performance and meet demanding requirements in harsh environments.

Solutions for Hospital Hardware

- Hall-Effect Magnetic Position Sensors
- Humidity Sensors
- MICRO SWITCH™ Position Switches
- Pressure Sensors
- Thermistors

Hall-Effect Magnetic Position Sensors in Medication Dispensing Cabinets

SS440/SS440R Series

The Hall-effect magnetic position sensor is designed for a variety of potential applications, including use with remote locking and unlocking of medication dispensing cabinets. Its small size often allows for design into many compact, automated, lower-cost assemblies. A thermally-balanced integrated circuit allows accuracy over a full temperature range.

Benefits to Customer

- **Energy-efficient:** Low power consumption enhances energy efficiency.
- **Enhances security:** Provides a level of security; minimizes medication dispensing errors by utilizing electronic sensing solutions to enable remote locking and unlocking of medication drawers.

- **Fast response:** Provides fast response time.
- **Reliable:** Improves durability and reduced repair and maintenance cost with a non-contact solution.
- **Small:** Small sensor size eases fit in drawers and enables smooth and efficient operation.



SS400 Series

Humidity Sensors in Medical Incubators

HIH-4000 Series, HIH-4020/4021 Series, HIH-4030/4031 Series, HIH-5030/5031 Series, HCH-1000 Series

Honeywell's humidity sensors monitor the medical incubator system to maintain a desired optimum level of humidification in the chamber with accurate dew-point and absolute humidity and moisture measurement

Benefits to Customer

- **Cost-effective:** Surface mount device (SMD) packaging on tape and reel allows for use in automated, high-volume, lower-cost pick-and-place manufacturing.

- **Durable:** Multi-layer construction and a hydrophobic filter provides enhanced resistance to condensation and contaminants.
- **Flexible:** Small, space-saving housing profile allows for application flexibility. The low current draw allows for use in low-current-drain, battery-operated systems.
- **Reliable:** Supports demanding system performance requirements with enhanced accuracy and response time.
- **Stable:** Prolongs maximum system life with reliable and stable output over various environmental conditions.



HIH-4000 Series

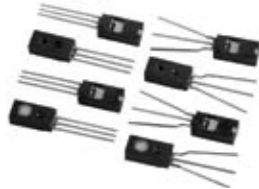

HIH-4020/4021 Series



HIH-4030/4031 Series



HIH-5030/5031 Series



HCH-1000 Series

MICRO SWITCH™ Position Switches in Hospital Beds

SM Series, SX Series, Z Series Basic Switches

Honeywell's precise position switches are used to determine minimum and maximum position of electrically adjustable hospital beds.

Benefits to Customer

- **MICRO SWITCH™ technology:** Accurate, repeatable and durable with extended life
- **Effective design:** Elongated mounting hold provides for easier, more accurate mounting

- **Small, light weight:** Simplifies design-in.



SM Series Basic Switch



SX Basic Switch



Z Series Basic Switch



Pressure Sensors in Hospital Beds

TruStability™ (HSC Series, SSC Series), 20PC Series, CPC Series Silicon Pressure Sensors

Honeywell's silicon pressure sensors are used to measure air pressure and monitor the inflation and deflation of the mattress air columns to minimize the chance that bedridden patients will develop bedsores.

Benefits to Customer

- **Accurate:** Accurate pressure monitoring in hospital beds allows enhanced stability and minimal drift over time. Honeywell's TruStability™ sensors' exceptional accuracy is a result of leading-edge technology, precise manufacturing processes and temperature compensation and calibration. TruStability™ sensors have two levels of accuracy: the standard accuracy SSC Series offers $\pm 2\%$ total error band, and the HSC Series offers $\pm 1\%$ total error band, better than most competitive products.

- **Reliable:** In demanding operations minimizes downtime and improves throughput with enhanced quality and reliability (<100 ppm).
- **Stable:** The long-term stability of Honeywell's TruStability™ sensors is the best in the industry.



Thermistors in Sterilizers, Autoclaves, Blood Refrigerators and Incubators

192 Series, 194 Series

Honeywell's discrete thermistor temperature sensors are designed to monitor temperature. The sensors are coupled to a microcontroller designed to measure air stream temperature and interact with the controller that regulates the temperature of the air stream. The packaged sensors are available as discrete components for customer-built assemblies, or Honeywell can provide a full assembly solution that the customer may simply pigtail into the system.

Benefits to Customer

- **Application flexibility:** Bare leads (192 Series) or insulated leads (194 Series) are designed to provide application flexibility.
- **Cost-effective:** Resistance temperature curve

interchangeability designed to offer standardization of circuit components and simplification of design/replacement enhances cost-effectiveness.

- **Small:** Small size often eases use in confined spaces.

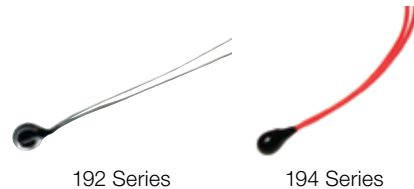



Surgical Instruments

Honeywell sensors have been used to help control the operation of various surgical instruments including orthopedic bone drills to detect the force of the drill bits and improve patient safety, regulating air and

gas pressure in endoscopes, controlling the pressure level for patient wound suction therapy and sensing pressure in a fluid management system.

Sensor Solutions for Surgical Fluid Management Systems

Force Sensors
Pressure Sensors

Force Sensors in Surgical Fluid Management

1865 Series, FSS Series, FSS-SMT Series

Honeywell's force sensors can help regulate the pressure at the pump head of a fluid management system, and as a back-up safety device to the direct pressure measurement at the joint.

Benefits to Customer

- **Portable:** Sensor's small size improves portability.
- **Energy efficient:** Sensor's small size allows low power consumption.
- **Reliable:** Enhanced quality (<100 ppm) provides enhanced reliability in many demanding operations.

- **Rugged design:** 1865 Series offers a rugged design that resists scratching and denting.
- **Stable:** Ability to detect pressure accurately over time with enhanced stability and low drift.



Pressure Sensors in Surgical Fluid Management Systems and Insufflators

Silicon Sensors: TruStability™ (HSC Series, SSC Series), ASDX Series

Honeywell's TruStability™ and ASDX Series silicon pressure sensors are used to sense pressure directly at the joint site during arthroscopic surgery, and monitor pressure for insufflators during endoscopic procedures.

Benefits to Customer

- **Accuracy:** Enhanced accuracy and ability to detect low pressure improves the accuracy of the pressure measurement. TruStability™ sensors' exceptional accuracy is a result of leading-edge technology, precise manufacturing processes and temperature compensation and calibration. TruStability™ sensors have two levels of accuracy: the standard accuracy SSC Series offers $\pm 2\%$ total error band, and the HSC Series offers $\pm 1\%$ total error band, better than most competitive products.
- **Improves patient safety:** Allows quick reaction with a fast response time.

- **Easy to design in:** Customization of pressure ranges, connections, calibration and temperature compensation minimizes customer's design-in effort.
- **Stable:** Stability is a measure of how little the output signal of the pressure sensor will change from measurement to measurement. The long-term stability of Honeywell's TruStability™ sensors is the best in the industry.





Dental Equipment

Honeywell's sensors are used in many potential dental equipment applications including dental imaging systems, dental chairs and pressure-operated dental instruments including drills, water sprays and air blasters.

Sensor Solutions for Dental Equipment

- Hall-Effect Magnetic Position Sensors
- Infrared Sensors
- Pressure Sensors

Hall-Effect Magnetic Position Sensors in Dental Imaging Systems and Dental Chairs SS549AT Series

The SS549AT Series Hall-effect position sensor is used to provide accurate motion control and positioning of the dental imaging system.

Benefits to Customer

- **Accurate motion control:** Detects home position and different segments of the sensor head rotation.
- **Energy-efficient:** Consumes less power, enhancing energy efficiency.

- **Fast response:** Provides fast response time.
- **Reliable:** Improved durability and reduced repair and maintenance cost with a non-contact solution.



SS549AT Series

Infrared Sensors in Dental Imaging Systems

HOA0881 Series, HOA1180 Series, HOA1870 Series

Honeywell's infrared sensors have been used in dental imaging systems to obtain dental images.

Benefits to Customer

- **Enables maximum position resolution:** Offers lead wires which provide alternate electrical connection when PC board mounting is not possible, often ideal for use in potential applications in which maximum position resolution is desired (HOA1870 Series).
- **Operates in contaminated environments:** Utilizes an infrared transmissive polysulfone housing which features smooth optical faces without external aperture openings, desirable when

aperture blockage from airborne contaminants is a possibility (HOA0881 Series).

- **Reliable:** Utilizes a built-in strain relief for maximum wire attachment strength (HOA0881 Series).



HOA0881 Series



HOA1180 Series



HOA1870 Series

Pressure Sensors in Pressure-Operated Dental Instruments

Silicon Sensors: 26PC Series

Honeywell's 26PC Series silicon pressure sensor is used to keep the water flow constant and at an adjusted level to provide a smooth operation of the dental instrument (e.g., drills, water sprays, air blasters).

Benefits to Customer

- **Reliable:** Minimizes downtime in demanding operations, and improves throughput with enhanced quality and reliability (<100 ppm).

- **Stable:** Pressure monitoring to control water flow level with enhanced accuracy.
- **Water-resistant and contaminant-resistant:** Ability to work with water flow and contaminants with the wet/wet compatibility and a flow path with minimal dead space.



26PC Series

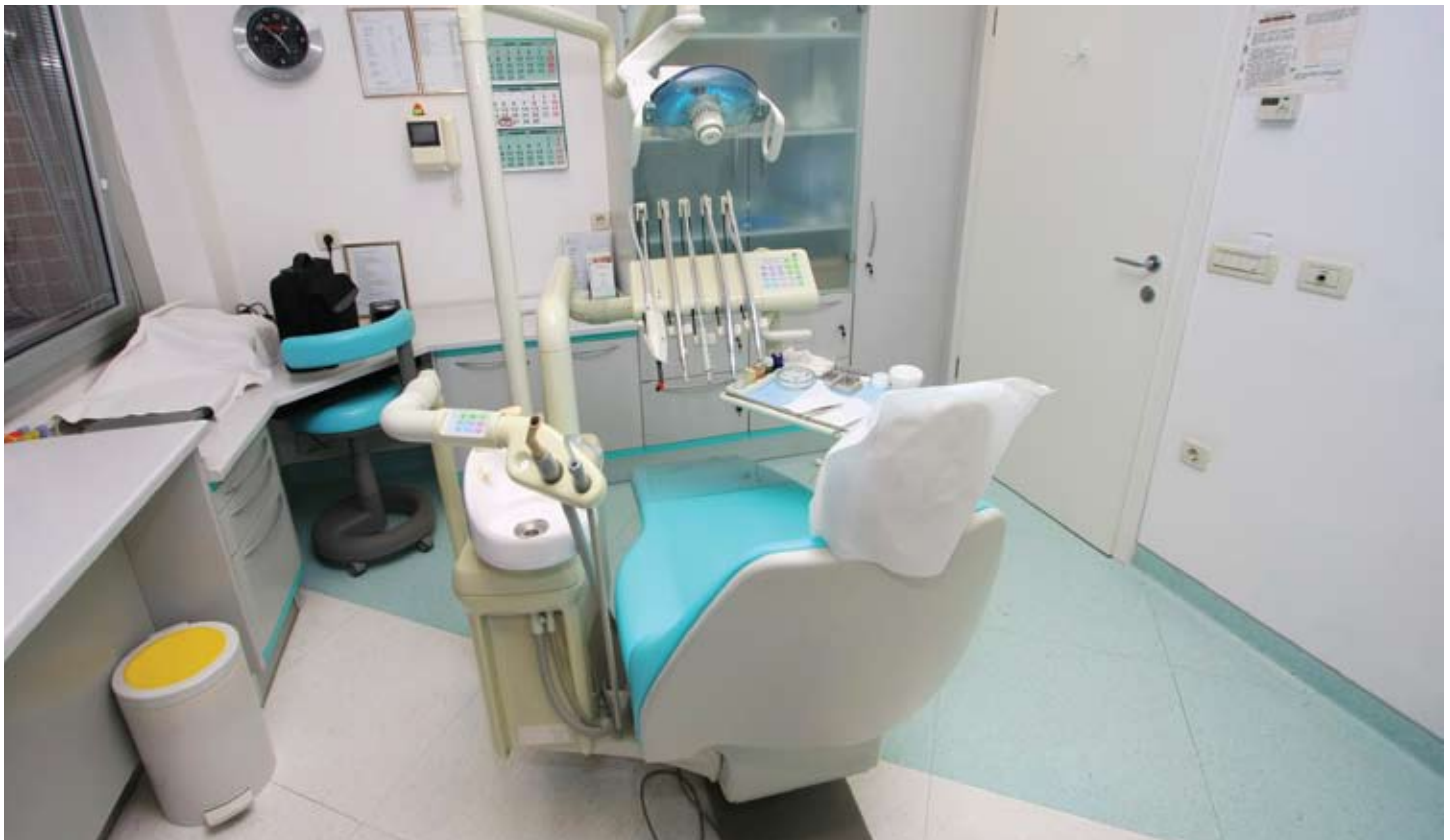

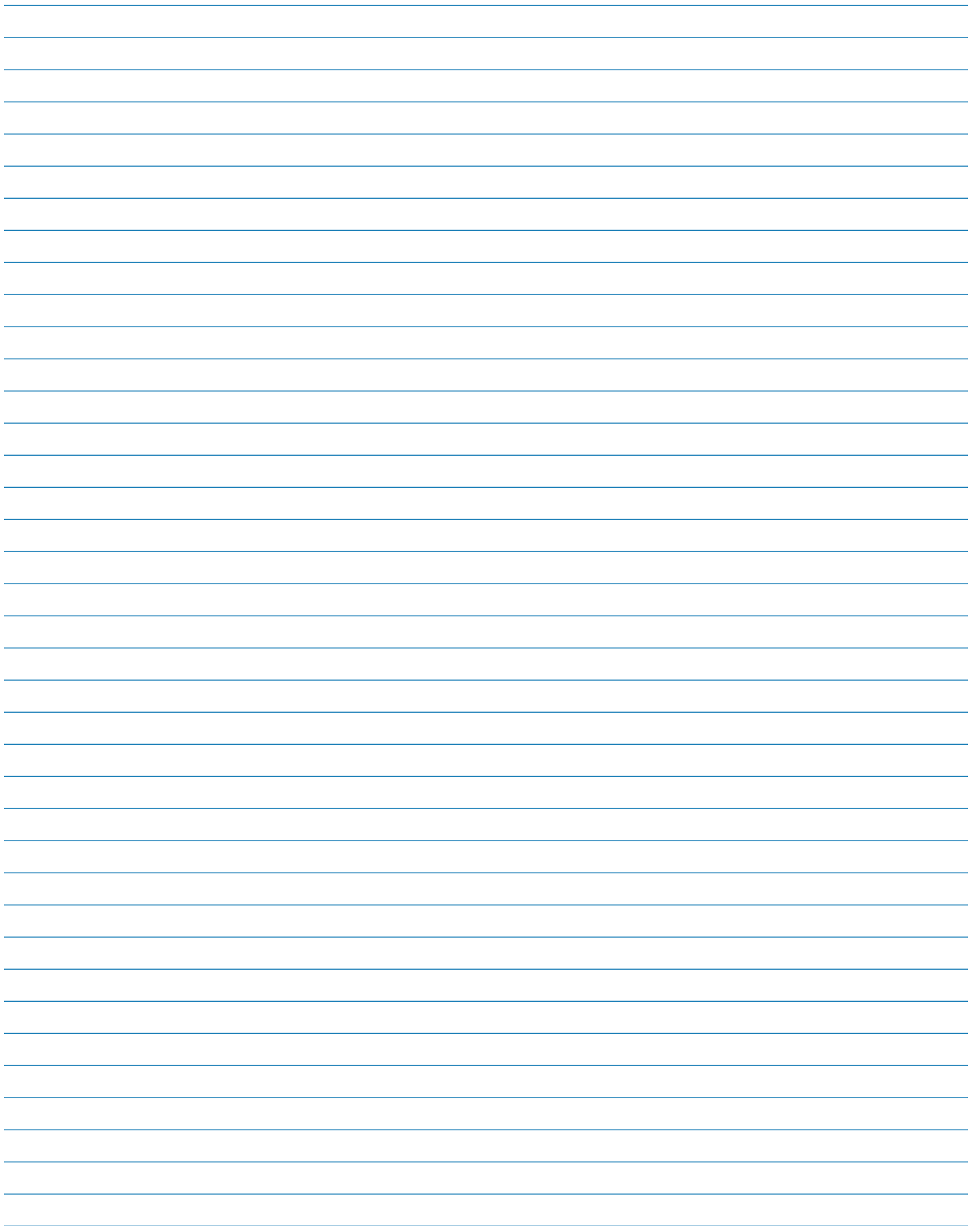

Warranty/Remedy

Honeywell warrants goods of its manufacture as being free of defective materials and faulty workmanship. Honeywell's standard product warranty applies unless agreed to otherwise by Honeywell in writing; please refer to your order acknowledgement or consult your local sales office for specific warranty details. If warranted goods are returned to Honeywell during the period of coverage, Honeywell will repair or replace, at its option, without charge those items it finds defective. The foregoing is buyer's sole remedy and is in lieu of all other warranties, expressed or implied, including those of merchantability and fitness for a particular purpose. In no event shall Honeywell be liable for consequential, special, or indirect damages. While we provide application assistance personally, through our literature and the Honeywell web site, it is up to the customer to determine the suitability of the product in the application. Specifications may change without notice. The information we supply is believed to be accurate and reliable as of this printing. However, we assume no responsibility for its use.

Customers know Honeywell by two simple words: "Problem solved."

Our corporate tradition of delivering quality and innovation is infused throughout Honeywell Sensing and Control, a global leader in cost-effective, problem-solving sensor and switch solutions.

For more information about Sensing and Control products, visit www.honeywell.com/sensing or call +1-815-235-6847
Email inquiries to info.sc@honeywell.com

Sensing and Control
Automation and Control Solutions
Honeywell
1985 Douglas Drive North
Golden Valley, MN 55422
USA
+1-815-235-6847
www.honeywell.com

WARNING

MISUSE OF DOCUMENTATION

- The information presented in this literature is for reference only. DO NOT USE this document as product installation information.
- Complete installation, operation and maintenance information is provided in the instructions supplied with each product.

Failure to comply with these instructions could result in death or serious injury.

For products not designed for safety applications:

WARNING

PERSONAL INJURY

DO NOT USE these products as safety or emergency stop devices or in any other application where failure of the product could result in personal injury.

Failure to comply with these instructions could result in death or serious injury.

For products designed for safety applications:

WARNING

RISK TO LIFE OR PROPERTY

Never use this product for an application involving serious risk to life or property without ensuring that the system as a whole has been designed to address the risks, and that this product is properly rated and installed for the intended use within the overall system.

Failure to comply with these instructions could result in death or serious injury.



Honeywell

