

# Design Guide & Applications Manual

## *For Maxi, Mini, Micro Family DC-DC Converter and Accessory Modules*



## Table of Contents

---

### Maxi, Mini, Micro Family DC-DC Converters

	Section	Pages
<a href="#">High Density DC-DC Converter Technology</a>	1	2 – 4
<a href="#">Control Pin Functions and Applications</a>	2	5 – 11
<a href="#">Design Requirements</a>	3	12 – 17
<a href="#">EMC Considerations</a>	4	18 – 19
<a href="#">Current Sharing in Power Arrays</a>	5	20 – 24
<a href="#">Thermal Performance Information</a>	6	25 – 30

### Accessory Modules

<a href="#">Autoranging Rectifier Module (ARM)</a>	7	31 – 35
<a href="#">Filter / Autoranging Rectifier Module (FARM)</a>	8	36 – 40
<a href="#">Modular AC Front-end System (ENMod)</a>	9	41 – 47
<a href="#">High Boost HAM</a>	10	48 – 52
<a href="#">Filter Input Attenuator Module (FIAM) Family</a>	11	53 – 55
<a href="#">Output Ripple Attenuator Module (MicroRAM)</a>	12	56 – 61

### Recommended Soldering Methods

<a href="#">Lead Free Pins (RoHS)</a>	13	62 – 66
<a href="#">TIn Lead Pins</a>	14	67 – 71

### Mounting Options

<a href="#">Surface Mount Socketing System (SurfMate)</a>	15	72 – 75
<a href="#">Through-hole Socket-mount System (InMate)</a>	16	76 – 79

<a href="#">Glossary of Technical Terms</a>	17	80 – 87
---	----	---------

The Maxi, Mini, Micro Family of DC-DC converters are an integral part of the company's overall component power solution strategy, (Figure 1–1), which includes advanced factory and design automation. The modules are available in an unlimited variety of standard versions, to the extent that the line between custom and standard DC-DC converter bricks becomes almost indistinguishable.

The design of the control, magnetic, switching, and packaging elements of the module resulted in a component with a power density of up to 120 W/in<sup>3</sup> (7,3 W/cm<sup>3</sup>) in three package sizes:

- Maxi 4.6" x 2.2" x 0.5" (117 x 55,9 x 12,7 mm)
- Mini 2.28" x 2.2" x 0.5" (57,9 x 55,9 x 12,7 mm)
- Micro 2.28" x 1.45" x 0.5" (57,9 x 36,8 x 12,7 mm)

The modules have one-third the number of parts of their predecessors.

While the natural by-products of this reduction in parts count has improved reliability and lower cost, the extra space also means that the bulk of the converter can now

be devoted almost exclusively to the power train (i.e., the magnetic and switching elements at the core of the design).

Resistors can be used to trim the output voltage up or down, if necessary. Six pin styles, three baseplate options, and a variety of data collection and reporting options are available. The devices have an operating temperature range of –55°C to 100°C and come in five product grades – E, C, T, H, and M.

Other specifications include a typical no-load to full-load regulation of ±0.5%, a programmable output of 10% to 110%, conversion efficiencies of up to 92% depending on the voltage combination and power level chosen, and an input-to-output isolation test voltage of 3,000 Vrms (4,242 Vdc). All models are parallelable with N+M fault tolerance and current sharing. Paralleling architectures feature DC or AC-coupled interface.

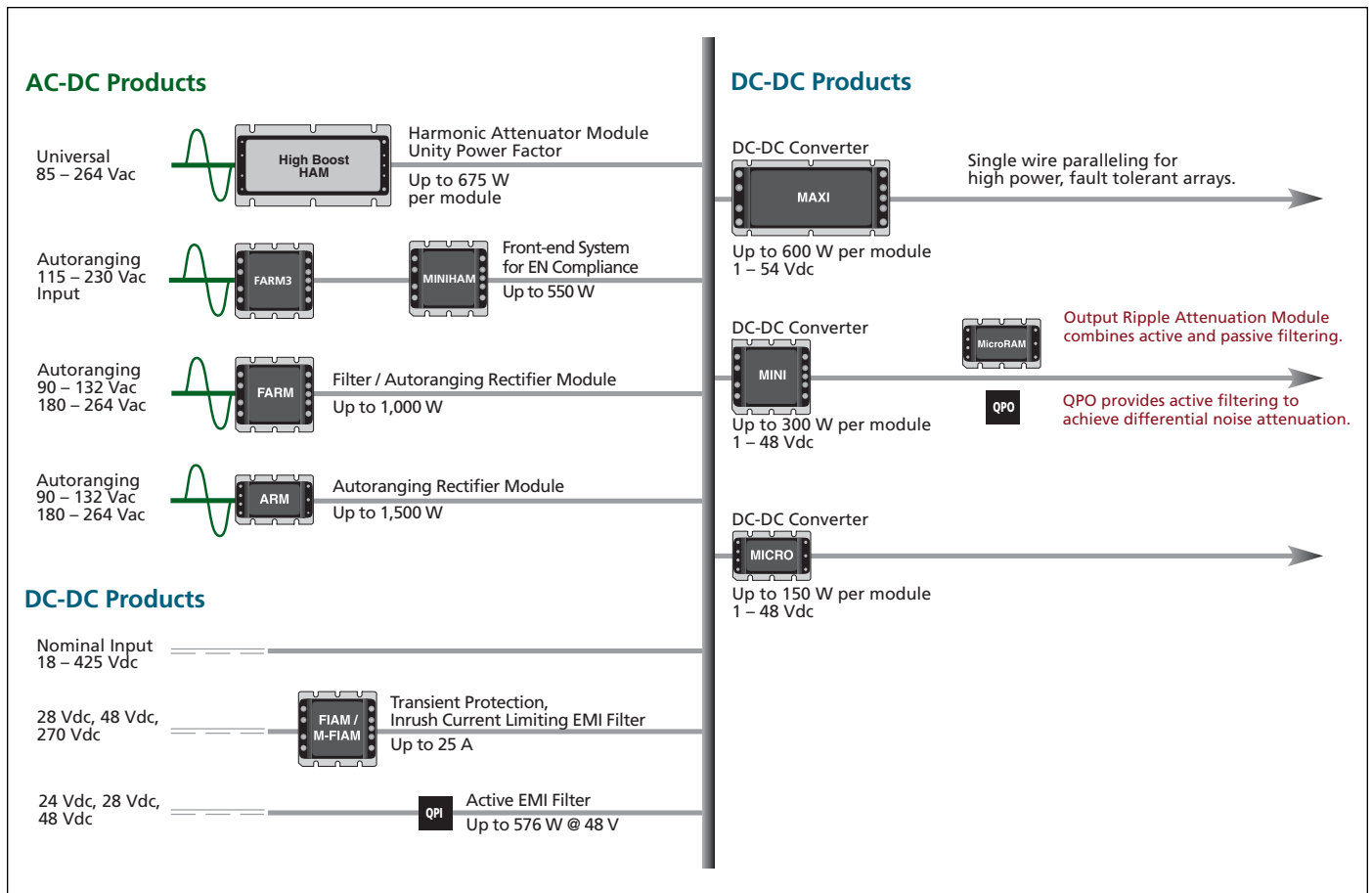

Figure 1–1 — Component power solutions with the Maxi, Mini, Micro Family

Key to the design of Maxi, Mini, Micro converters is its high level of component-level integration. (Figure 1–2) With the aid of hybrid technology, the device packs all control functions and active circuitry into two (primary and secondary side) ICs occupying a total volume of less than 1/10 in<sup>3</sup> (1,6 cm<sup>3</sup>) each.

With Maxi, Mini, Micro devices, the plated-cavity transformer cores use copper armor, plated onto the ferrite core, to more closely confine the magnetic flux to couple widely separated primary and secondary windings. The wider separation provides greater isolation and therefore lowers input-to-output parasitic capacitance and noise. The plated cavity also serves to conduct heat away from the transformer to the baseplate, thus increasing the power-handling capability of the power train and minimizing temperature rise.

The power-train assembly is contained between the baseplate and a terminal-block assembly, with input and

output pins recessed. This allows the converter body to be mounted into an aperture in the PCB to reduce the height above board. The modules may be wave soldered or plugged into through-hole or surface-mount sockets.

The Maxi, Mini, Micro devices use a proprietary, low-noise, integrated power device that has an order of magnitude lower parasitic effect.

The advances made in the overall design of the Maxi, Mini, Micro Family DC-DC converters have been complemented by equally significant advances in the technology used to manufacture them. Vicor invested in a custom, fully-automated assembly line specifically designed for the assembly of Maxi, Mini, Micro power components. To further augment its Maxi, Mini, Micro product offering, Vicor has created an online user-interface tool, [PowerBench™](#), that allows customers to specify DC-DC module requirements anytime, anywhere via the internet.

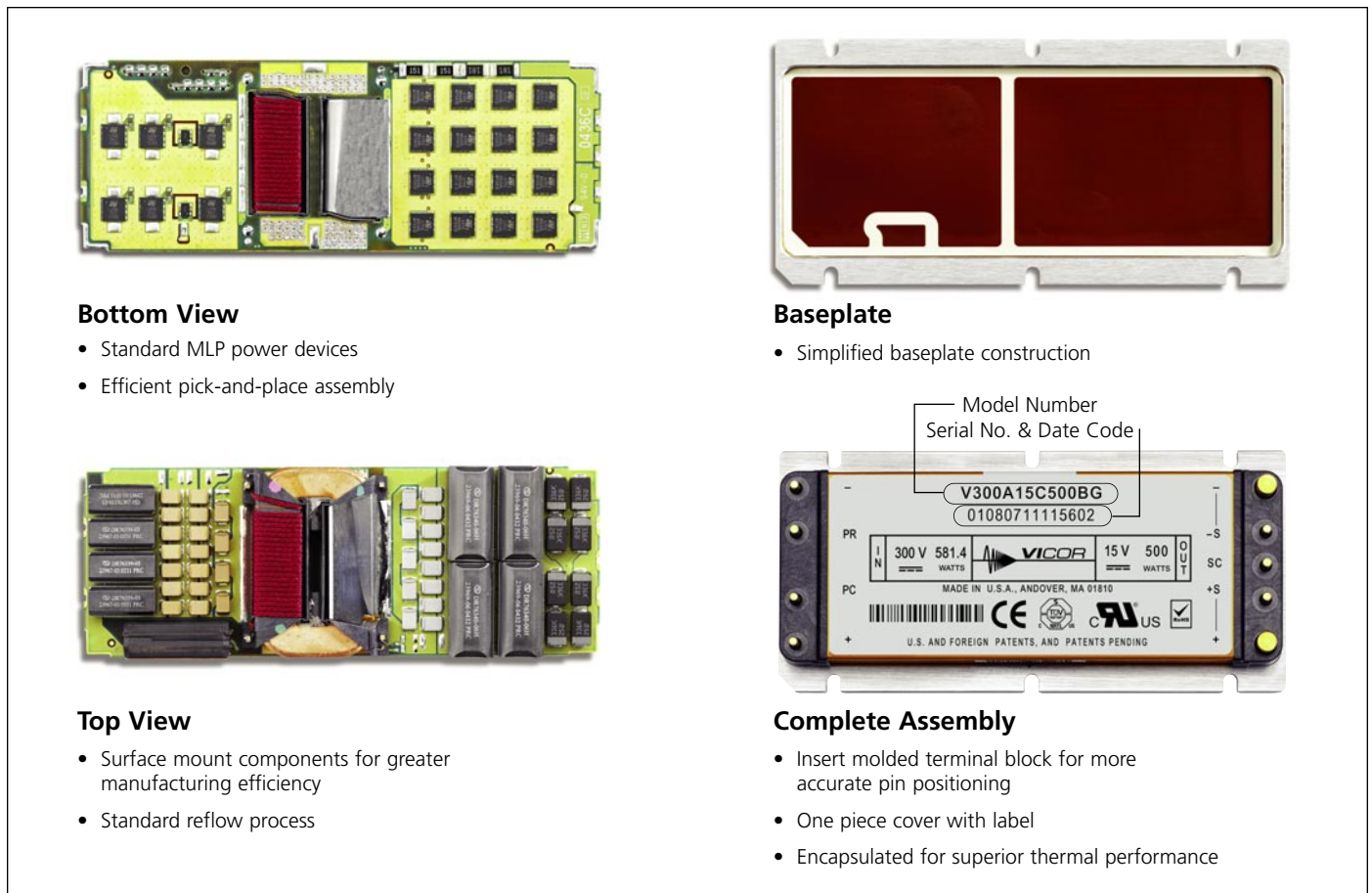

Figure 1–2 — Maxi assembly shows high level of integration.

The Maxi, Mini, Micro's ZCS / ZVS power-processing architecture (Figure 1-3) enables efficient, low-noise, high-frequency operation. The main switch is common drain for improved thermal and noise management, the reset switch located within the primary control IC is common source for ease of control.

The control circuitry is integrated into two (primary and secondary side) ICs. The result is a significant reduction in

parts with the ensuing savings in cost and increase in reliability. This integration also provides extra room for the power train.

Maxi, Mini, Micro transformers place the primary and secondary windings far apart, but contain the magnetic flux using a copper armor plated onto the ferrite core. The armor also conducts excess heat to the baseplate.

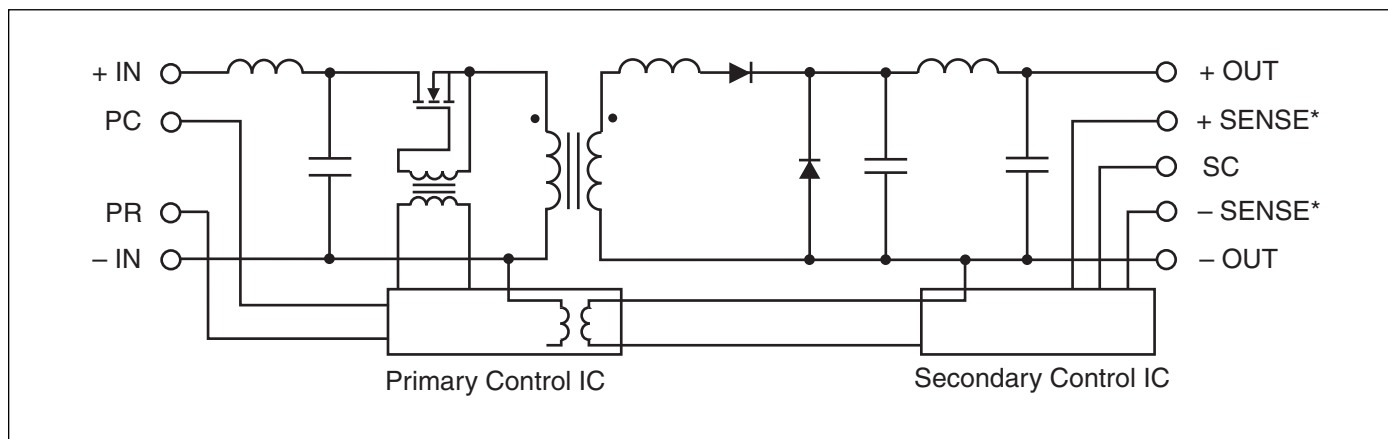

Figure 1-3 — Maxi, Mini, Micro: Basic power train and control (\*Not included in Micro family)

**PRIMARY CONTROL (PC PIN)**

**Module Enable / Disable.** The module can be disabled by pulling the PC below 2.3 V with respect to the –Input. This should be done with an open-collector transistor, relay, or optocoupler. Multiple converters may be disabled with a single transistor or relay via “ORing” diodes. When using a mechanical switch or relay to control the PC pin, please ensure that the contacts are properly debounced with a capacitor (10 nF max.) to avoid switch bounce.

An optocoupler must be used when converters are located on different PC boards, when a common-mode inductor is used directly at the module input, or when the distance between the converters would cause excessive voltage drops. Under no circumstances should the PC pin be pulled negative more than a diode drop below the module –IN. (Figure 2–1) When the PC pin is pulled low the PC current will pulse similar to the PC voltage shown in Figure 2–4. When the outputs of two or more converters are connected in a parallel array to increase system power the converters should be “group enabled” to ensure that all the converters start at the same time. The PC pins of all converters in the array should be controlled by an external circuit which will enable the converters once the input voltage is within the normal operating range.

**Primary Auxiliary Supply.** At 5.75 V, the PC can source up to 1.5 mA. In the example shown in Figure 2–3, PC powers a LED to indicate the module is enabled. Another example of an isolated on-state indicator is shown in Figure 2–5.

**NOTE:** When the module has detected a fault or when the input voltage is above or below the normal operating range the PC voltage will pulse.

**Module Alarm.** The module contains “watchdog” circuitry that monitors input voltage, operating temperature, and internal operating parameters. (Figures 2–2a and 2–2b) If any of these parameters is outside their allowable operating range, the module will shut down and PC will go low. (Figure 2–4) Then PC will periodically go high and the module will check to see if the fault (as an example, input undervoltage) has cleared. If the fault has not been cleared, PC will go low again and the cycle will restart. The SC pin will go low when a fault occurs and return to its normal state after the fault has been cleared. An example of using a comparator for monitoring on the secondary is shown in Figures 2–6a and 2–6b.

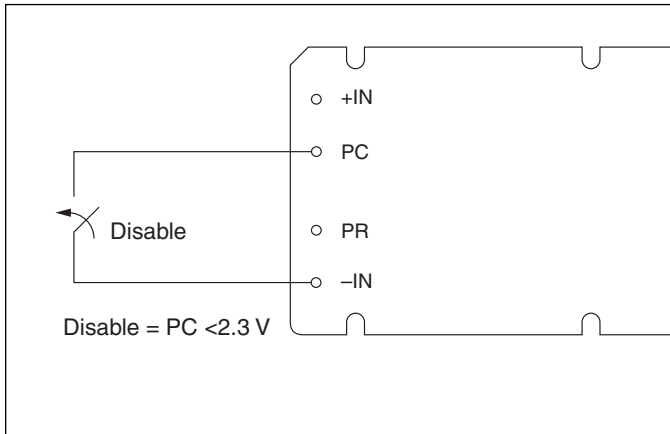

Figure 2–1 — Module Enable / Disable

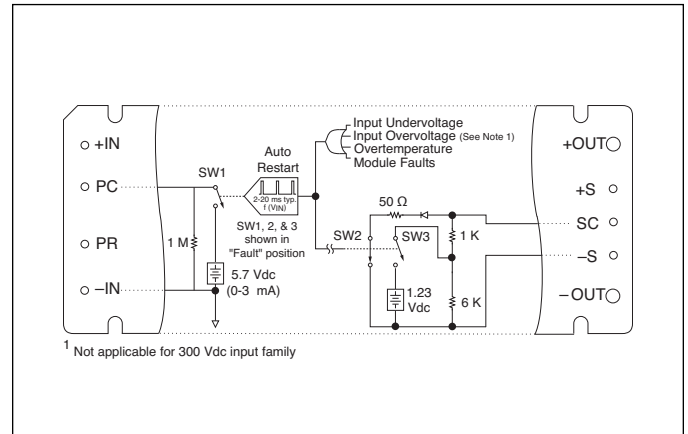

Figure 2–2a — PC and SC module alarm logic (Maxi / Mini)

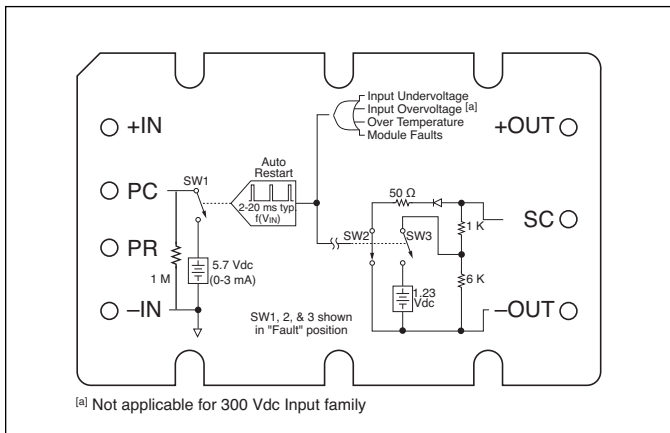

Figure 2–2b — PC and SC module alarm logic (Micro)

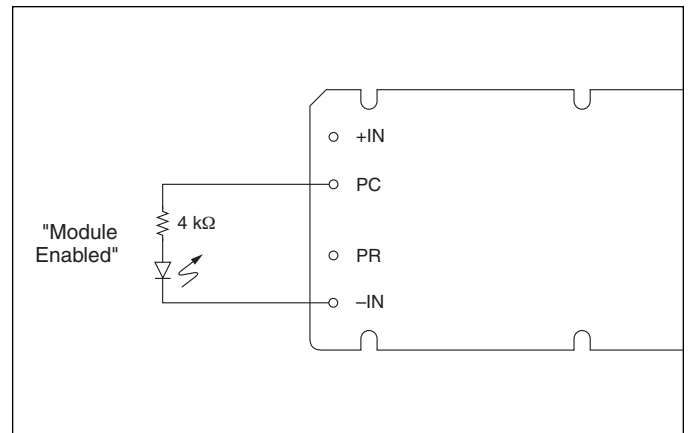

Figure 2–3 — LED on-state indicator

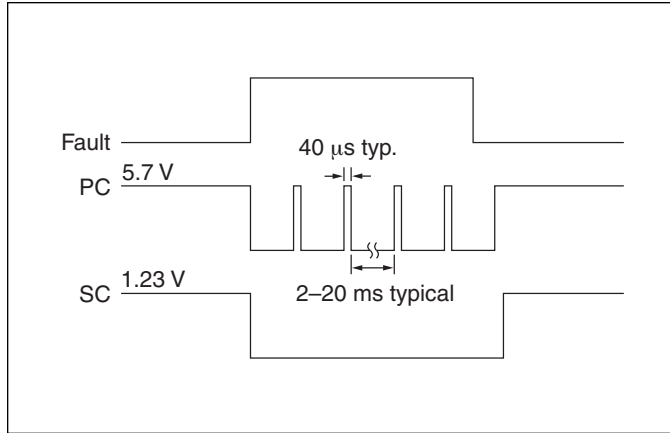

Figure 2-4 — PC / SC module alarm timing

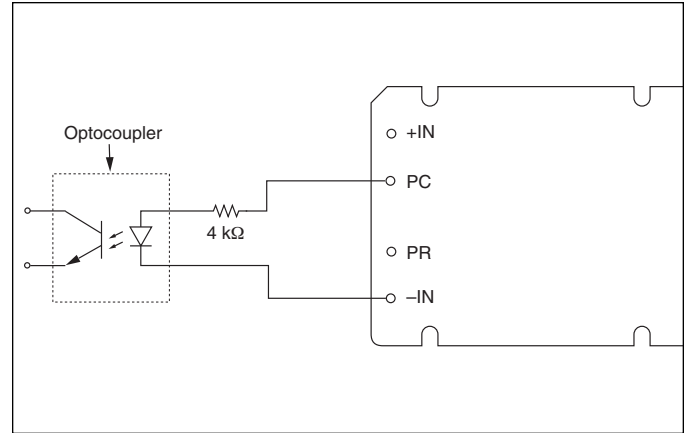

Figure 2-5 — Isolated on-state indicator

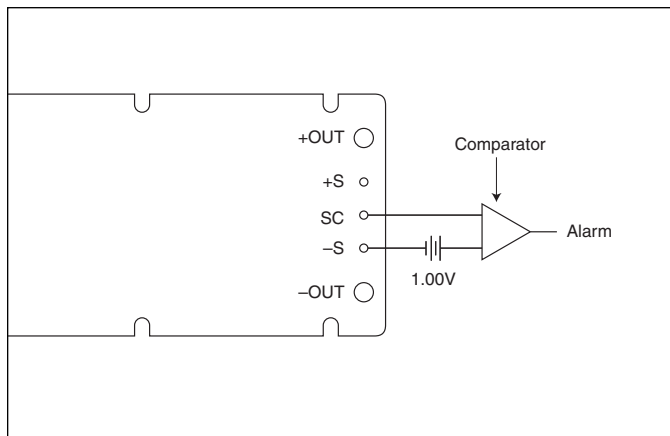

Figure 2-6a — Secondary side on-state (Maxi / Mini)

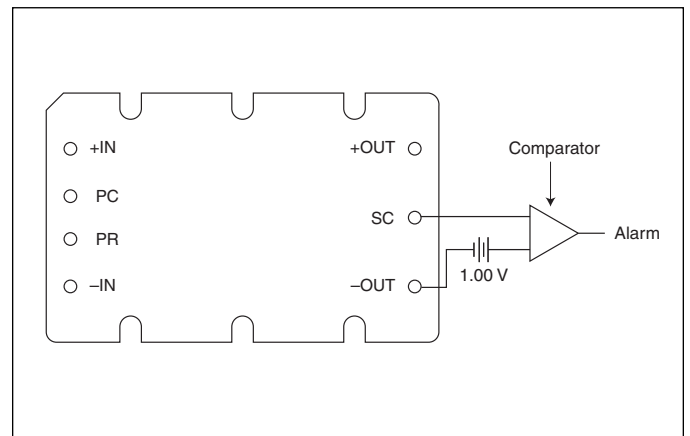

Figure 2-6b — Secondary side on-state (Micro)

### PARALLEL BUS (PR PIN)

A unique feature has been designed into Vicor Maxi, Mini, Micro converter modules that facilitates parallel operation for power expansion or redundancy. The PR pin is a bi-directional port that transmits and receives information between modules. The pulse signal on the parallel (PR) bus serves to synchronize the high-frequency switching of each converter which in turn forces them to load share. These modules possess the ability to arbitrate the leadership role; i.e., a democratic array. The module that assumes command transmits the sync pulse on the parallel bus while all other modules on the bus listen. In the event of a failure of the lead module, the array “elects” a new leader with no interruption of the output power.

Connection methods for the PR bus include:

1. DC-coupled single-wire interface: All PR pins are directly connected to one another. This interface supports current sharing but is not fault tolerant.

Negative (-) In pins must be tied to the same electric potential. This method may normally be used with a maximum of three converters.

2. AC-coupled single-wire interface: All PR pins are connected to a single communication bus through 0.001 μF (500 V) capacitors. This interface supports current sharing and is fault tolerant except for the communication bus. (Figure 2-7) This method may normally be used with a maximum of three converters.
3. Transformer-coupled interface: Modules or arrays of modules may also be interfaced to share a load while providing galvanic isolation between PR pins via a transformer-coupled interface. For large arrays, buffering may be required. The power source for the buffer circuit may be derived from the PC pins. For arrays of four or more modules, the transformer coupled interface is recommended. (Figure 2-8)

**PARALLEL OPERATION CONSIDERATIONS**

Care must be taken to avoid introducing interfering signals (noise) onto the parallel bus that may prevent proper load sharing between modules, instability, or module failure. One possible source of interference is input ripple current conducted via the + and -Input power pins. The PR signal and DC power input share a common return, which is the -Input pin. Steps should be taken to decouple AC components of input current from the parallel bus. The input to each converter (designated as + and - pins on the input side of the module) should be bypassed locally with a 0.2  $\mu\text{F}$  ceramic or film capacitor. This provides a shunt path for high frequency input ripple current. A Y-rated 4,700 pF capacitor should be connected between both the + and -Input pins and baseplate of each module, thus creating a shunt path for common-mode components of current. Attention to the PC board artwork should minimize the parasitic impedance between -Input pins of parallel modules to ensure that all PR pins are referenced to the same potential, or use a transformer coupled interface. Modules should be placed physically close to each other and wide copper traces (0.75 in./19 mm, 2 oz. copper) should be used to connect power input pins. A dedicated layer of copper is the ideal solution.

Some applications require physical separation of paralleled modules on different boards, and/or input power from separate sources. For applications using separate sources, please refer to the "Hot-Swap Capability Eliminates Downtime" application note on Vicor's website. In these cases, transformer coupling of the PR signal, per Figure 2-8, is required to prevent inter-module common-mode noise

from interfering with the sync pulse transmission. High-speed buffering may be required with large arrays or if the distance between modules is greater than a few inches. This is due to the fact that all modules, except the one that's talking, are in the listening mode. Each listener presents a load to the master (talker), which is approximately 500  $\Omega$  shunted by 30 pF capacitance. Long leads for the interconnection introduce losses and parasitic reactance on the bus, which can attenuate and distort the sync pulse signal. The bandwidth of the bus must be at least 60 MHz and the signal attenuation less than 2 dB. In most cases, transformer coupling without buffering is adequate. Many applications may benefit from the addition of Z1, in series with the PR Pin of each converter. A low Q 33  $\Omega$  @ 100 Mhz ferrite bead or a 5 - 15 Ohm resistor may be used to improve the PR signal waveform. Although this is not a requirement, it can be very helpful during the debug stage of large converter arrays to help improve the PR pulse wave shape and reduce reflections. Again, careful attention must be given to layout considerations. When the outputs of two or more converters are connected in a parallel array to increase system power the converters should be "group enabled" to ensure that all the converters start at the same time. The PC pins of all converters in the array should be controlled by an external circuit which will enable the converters once the input voltage is within the normal operating range. Please consult with [Applications Engineering at any Vicor Technical Support Center](#) for additional information.

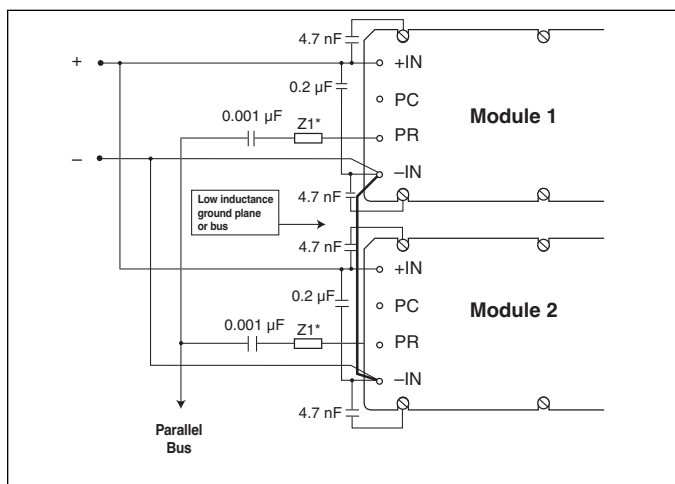

Figure 2-7 — AC coupled single-wire interface

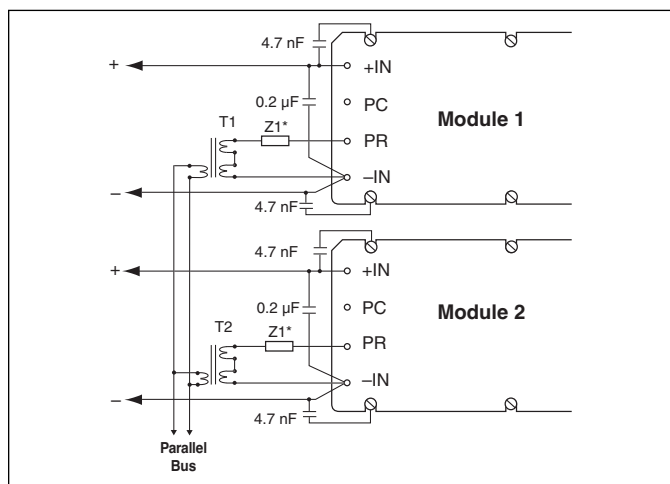

Figure 2-8 — Transformer-coupled interface

### CONTROL FUNCTIONS AND OUTPUT CONSIDERATIONS

**Parallel Operation (PR Pin).** The PR pin supports paralleling for increased power with N+1 or N+M redundancy. Modules of the same part number will current share if all PR pins are suitably interfaced. Figures 2–9 and 2–10 show connections for the Maxi and Mini modules; Figure 2–11 shows connections for the Micro array. Applications containing two or more Micro modules must define a designated master (talker) by stagger trimming the output voltage of each subsequent module down by at least 2%, or setting the remaining Micro modules in the system as designated listeners by connecting the SC pin to the negative output pin.

**PR Pin Considerations.** When paralleling modules, it is important that the PR signal is communicated to all modules within the parallel array. Modules that do not receive a PR pulse in a parallel array will not current share and may be damaged by running in an over-power condition.

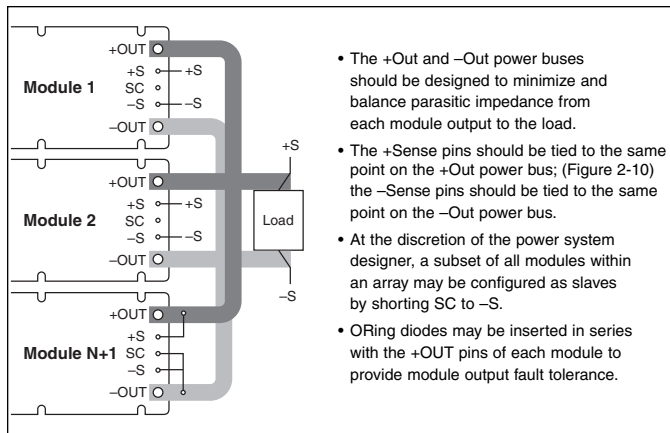

Figure 2–9 — N+1 module array output connections (Maxi and Mini)

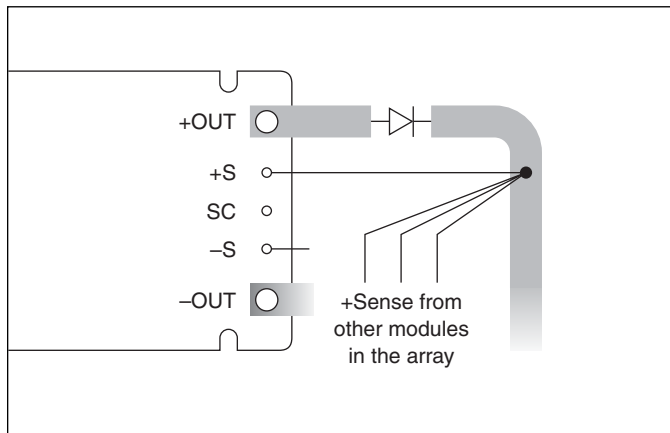

Figure 2–10 — ORing diodes connections (Maxi and Mini)

All modules in an array must be of the same part number. Series connection of outputs is accomplished without connecting the PR pins and allowing each module to regulate its own output voltage. Since the same current passes through the output of each module with the series connection, power sharing is inherent. Series connection of inputs requires special precautions, please contact Applications Engineering for assistance.

**Array Output Overvoltage Protection (OVP).** In order to maintain the highest possible uptime of a parallel array the converters use an output overvoltage protection system (OVP) that is highly resistant to false tripping. For the converter to shut down due to an OVP condition two conditions must be satisfied (logical AND);

1. The voltage at the output terminals must be greater than the OVP set point.
2. The secondary control IC within the converter must be requesting a power conversion cycle from the internal primary control IC.

By using this logic, false tripping of individual converters due to externally induced OVP conditions such as load dumps or, being driven by an external voltage source at the output terminals is minimized.

Modules connected in a parallel array rely on the active master module for OVP of the entire array. Modules acting as boosters (slaves) in the array are receiving external requests for power conversion cycles (PR pulse) and will not shut down from an OVP condition. Therefore it is imperative that the + and -Output pins of modules connected in a parallel array **never** be allowed to become open circuited from the output bus. An open circuit at the output terminals will result in terminal voltages far in excess of the normal rating causing permanent damage to the module and possible hazardous conditions.

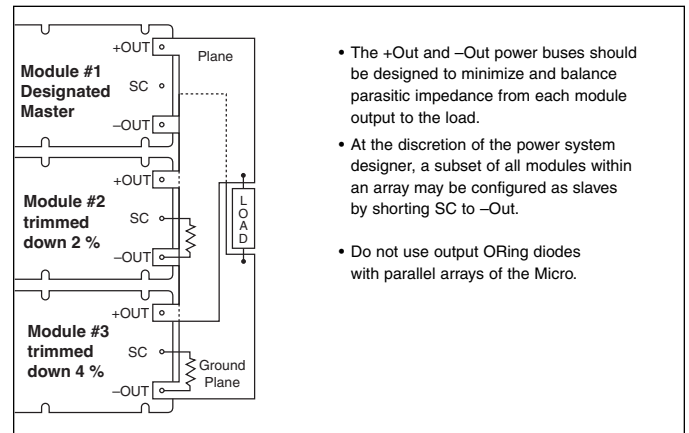

Figure 2–11 — Parallel module array output connections (Micro)

**CONTROL FUNCTIONS, SECONDARY CONTROL (SC PIN)**

**Output Voltage Programming.** The output voltage of the converter can be adjusted or programmed via fixed resistors, potentiometers or DACs.

**Trim Down.** The converter is **not** a constant power device; it has a constant current limit. Hence, available output power is reduced by the same percentage that output voltage is trimmed down. Do not exceed maximum rated output current. The trim down resistor must be connected to the –S pin (–Out pin on a Micro). (Figures 2–12a and 2–12b)

**Trim Up.** The converter is rated for a maximum delivered power. To ensure that maximum rated power is not exceeded, reduce maximum output current requirement in the application by the same percentage increase in output voltage. The trim up resistor must be connected to the +S pin (+OUT pin on a Micro.) Do not trim the converter above maximum trim range (+10%) or the output over voltage protection circuitry may be activated. (Figures 2–13a and 2–13b)

**SC Pin and Output Voltage Trimming.** If no connection is made to the SC pin, the SC pin voltage will be 1.23 V referenced to –S (–OUT pin on a Micro) and the output of the converter will equal the nominal output voltage. When the SC pin voltage is set by an external source such as a D/A converter, the % change in SC will be equal the % change in the output voltage.

For example, an application requires a +10, 0% (nominal), and a –15% output voltage adjustment for a 48 V output converter. Referring to the table below, the voltage that should be applied to the SC pin would be as follows:

V <sub>sc</sub>	V <sub>out</sub>	Change from nominal
1.046	40.8	–15%
1.230	48.0	0%
1.353	52.8	+10%

Circuits such as op-amps and D/A converters, which directly drive the SC pin, should be designed to limit the applied voltage to the SC pin. It is also important to consider voltage excursions that may occur during initialization of the external circuitry. The external circuit must be referenced to the –S pin (–Out on Micro). See Figure 2–14 for remote sense implementation on Micro.

For systems that require an adjustable output voltage, it is good practice to limit the adjustment range to a value only slightly greater than that required. This will increase the adjustment resolution while reducing noise pickup.

It is recommended that the maximum rate of change applied to the SC pin be limited to 30 Hz, sinusoidal. Small step-up changes are permissible; however, the resultant change in the output voltage can create significant current demands due to charge requirements of both the internal and external output capacitance. In no case should the converter be driven beyond rated continuous output current. The response to programming a lower output voltage is limited by the energy stored in both the internal and external output capacitance and the load. The converter cannot sink current to lower the output voltage other than a minimal internal preload.

Contact [Applications Engineering](#) if the module's output is to be dynamically trimmed.

Trimming resistor calculators are available on Vicor's web site at [www.vicorpower.com/tools](http://www.vicorpower.com/tools). (Figure 2–16)

Resistor values can be calculated for fixed trim up, fixed trim down, and for variable trim up or down. In addition to trimming information, the web also includes design tips, applications circuits, EMC suggestions, thermal design guidelines and PDF data sheets for all Vicor products. Evaluation Boards (Figure 2–15) are available for the Maxi, Mini and Micro DC-DC converters.



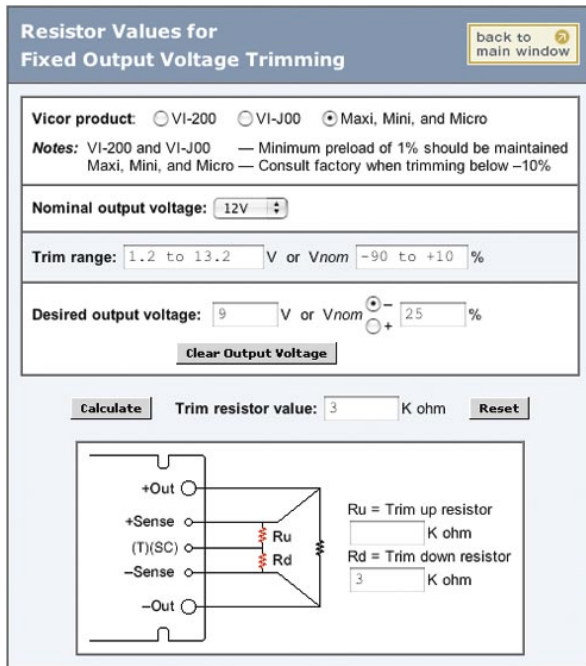

Figure 2-16 — Online trim calculator

**EVALUATION BOARDS**

- Three styles: Maxi, Mini or Micro
- Short pin and Long pin compatible
- Easy I/O and control connections
- Includes fusing and capacitors
- Can be paralleled for higher power arrays

DESCRIPTION	PART NUMBER
Maxi board style	24644R
Mini board style	24645R
Micro board style	24646R

## SAFETY CONSIDERATIONS

**Fusing.** Safety agency conditions of acceptability require that the module positive (+) Input terminal be fused and the baseplate of the converter be connected to earth ground. The following table lists the acceptable fuse types

and current rating for the Maxi, Mini, Micro Family of DC-DC converters. The [Safety Certification link](#) on the Vicor web site should always be consulted for the latest fusing requirements.

**Acceptable Fuse Types and Current Rating for the Maxi, Mini, Micro Family of Converters**

Package Size	Input Voltage	Output Voltage	Output Power	Required Fuse
Maxi (A)	375	2	160	Bussmann PC-Tron 5A
Maxi (A)	375	3.3	264 / 200	Bussmann PC-Tron 5A
Maxi (A)	375	5, 8	400 / 300	Bussmann PC-Tron 5A
Maxi (A)	375	12, 15, 24, 28, 32, 36, 48, 54	600 / 400	Bussmann PC-Tron 5A
Mini (B)	375	2	100	Bussmann PC-Tron 5A
Mini (B)	375	3.3	150 / 100	Bussmann PC-Tron 5A
Mini (B)	375	5, 8	200 / 150	Bussmann PC-Tron 5A
Mini (B)	375	12, 15, 24, 28, 36, 48	300 / 200	Bussmann PC-Tron 5A
Micro (C)	375	2	50	Bussmann PC-Tron 3A
Micro (C)	375	3.3	75 / 50	Bussmann PC-Tron 3A
Micro (C)	375	5, 8	100 / 50	Bussmann PC-Tron 3A
Micro (C)	375	12, 15, 24, 28, 36, 48	150 / 75	Bussmann PC-Tron 3A
Maxi (A)	300	2	160	Bussmann PC-Tron 5A
Maxi (A)	300	3.3	264 / 200	Bussmann PC-Tron 5A
Maxi (A)	300	5, 8	400 / 300	Bussmann PC-Tron 5A
Maxi (A)	300	12, 15, 24, 28, 36, 48	500 / 400	Bussmann PC-Tron 5A
Mini (B)	300	2	100	Bussmann PC-Tron 5A
Mini (B)	300	3.3	150 / 100	Bussmann PC-Tron 5A
Mini (B)	300	5, 8	200 / 150	Bussmann PC-Tron 5A
Mini (B)	300	12, 15, 24, 28, 36, 48	250 / 150	Bussmann PC-Tron 5A
Micro (C)	300	2	50	Bussmann PC-Tron 3A
Micro (C)	300	3.3	75 / 50	Bussmann PC-Tron 3A
Micro (C)	300	5, 8	100 / 50	Bussmann PC-Tron 3A
Micro (C)	300	12, 15, 24, 28, 36, 48	150 / 75	Bussmann PC-Tron 3A
Maxi (A)	150	3.3	264 / 200	Bussmann ABC-8
Maxi (A)	150	5, 8	400 / 300	Bussmann ABC-8
Maxi (A)	150	12, 15, 24, 28, 36, 48	500 / 400	Bussmann ABC-8
Mini (B)	150	3.3	150 / 100	Bussmann PC-Tron 5A
Mini (B)	150	5, 8	200 / 150	Bussmann PC-Tron 5A
Mini (B)	150	12, 15, 24, 28, 36, 48	250 / 150	Bussmann PC-Tron 5A
Micro (C)	150	3.3	75	Bussmann PC-Tron 3A
Micro (C)	150	5, 8	100	Bussmann PC-Tron 3A
Micro (C)	150	12, 15, 24, 28, 36, 48	150	Bussmann PC-Tron 3A
Maxi (A)	110	3.3	200 / 150	Bussmann ABC-8
Maxi (A)	110	5, 8	300 / 200	Bussmann ABC-8
Maxi (A)	110	12, 15, 24, 28, 36, 48	400 / 300	Bussmann ABC-8
Mini (B)	110	3.3	100 / 75	Bussmann PC-Tron 5A
Mini (B)	110	5, 8	150 / 100	Bussmann PC-Tron 5A
Mini (B)	110	12, 15, 24, 28, 36, 48	200 / 150	Bussmann PC-Tron 5A
Micro (C)	110	3.3	50	Bussmann PC-Tron 3A
Micro (C)	110	5, 8	75	Bussmann PC-Tron 3A
Micro (C)	110	12, 15, 24, 28, 36, 48	100	Bussmann PC-Tron 3A

## Acceptable Fuse Types and Current Rating for the Maxi, Mini, Micro Family of Converters

Package Size	Input Voltage	Output Voltage	Output Power	Required Fuse
Maxi (A)	72	3.3	264	Bussmann ABC-12
Maxi (A)	72	5, 8	300	Bussmann ABC-12
Maxi (A)	72	12, 15, 24, 28, 36, 48	400	Bussmann ABC-12
Mini (B)	72	3.3	100	Bussmann ABC-8
Mini (B)	72	5, 8	150	Bussmann ABC-8
Mini (B)	72	12, 15, 24, 28, 36, 48	250	Bussmann ABC-8
Micro (C)	72	3.3	75	Bussmann PC-Tron 5A
Micro (C)	72	5, 8	100	Bussmann PC-Tron 5A
Micro (C)	72	12, 15, 24, 28, 36, 48	150	Bussmann PC-Tron 5A
Maxi (A)	48	3.3	264	Bussmann ABC-10
Maxi (A)	48	5, 8	400	Bussmann ABC-15
Maxi (A)	48	12, 15, 24, 28, 36, 48	500	Bussmann ABC-20
Mini (B)	48	2	100	Bussmann ABC-8
Mini (B)	48	3.3	150	Bussmann ABC-8
Mini (B)	48	5, 8	200	Bussmann ABC-10
Mini (B)	48	12, 15, 24, 28, 36, 48	250	Bussmann ABC-10
Micro (C)	48	2	50	Bussmann PC-Tron 5A
Micro (C)	48	3.3	75 / 50	Bussmann PC-Tron 5A
Micro (C)	48	5, 8	100 / 75 / 50	Bussmann ABC-8
Micro (C)	48	12, 15, 24, 28, 36, 48	150 / 75	Bussmann ABC-8
Maxi (A)	28	3.3	150	Bussmann ABC-25
Maxi (A)	28	5	175	Bussmann ABC-25
Maxi (A)	28	6.5, 8, 12, 15, 24, 28, 36, 48	200	Bussmann ABC-30
Mini (B)	28	3.3	75	Bussmann ABC-15
Mini (B)	28	5	75	Bussmann ABC-15
Mini (B)	28	12, 15, 24, 28, 36, 48	150	Bussmann ABC-15
Micro (C)	28	3.3	50	Bussmann ABC- 8
Micro (C)	28	5	50	Bussmann ABC-10
Micro (C)	28	12, 15, 24, 28, 36, 48	100	Bussmann ABC-10
Maxi (A)	24	3.3	264 / 200	Bussmann ABC-25
Maxi (A)	24	5, 8, 12, 15, 24, 28, 36, 48	400 / 300	Bussmann ABC-30
Mini (B)	24	3.3	150 / 100	Bussmann ABC-15
Mini (B)	24	5, 8, 12, 15, 24, 28, 36, 48	200 / 150	Bussmann ABC-15
Micro (C)	24	3.3	75 / 50	Bussmann ABC-8
Micro (C)	24	5, 8, 12, 15, 24, 28, 36, 48	100 / 50	Bussmann ABC-10

The fuse must be in series with the positive (+) Input lead. Fusing the negative (–) Input lead does not provide adequate protection since the PR and PC terminals of the converter are referenced to the –Input. If a fuse located in the –Input lead were to open, the PR and PC terminals could rise to the potential of the +Input. This may damage any converter or circuitry connected to these pins. The fuse should not be located in an area with a high ambient temperature as this will lower the current rating of the fuse.

### THERMAL AND VOLTAGE HAZARDS

Vicor component power products are intended to be used within protective enclosures. Vicor DC-DC converters work effectively at baseplate temperatures, which could be harmful if contacted directly. Voltages and high currents (energy hazard) present at the terminals and circuitry connected to them may pose a safety hazard if contacted or if stray current paths develop. Systems with removable circuit cards or covers which may expose the converter(s) or circuitry connected to the converters, should have proper guarding to avoid hazardous conditions.

The module pins are intended for PCB mounting either by wave soldering to a PCB or by insertion into one of the recommended PCB socket solutions. Use of discrete wire soldered directly to the pins may cause intermittent or permanent damage to the module; therefore, it is not recommended as a reliable interconnection scheme for production as a final released product. In addition, modules that have been soldered into printed circuit boards and have subsequently been removed should not be reused.

### PC PIN

The PC pin should be used only to; disable the module, provide a bias to input referenced circuitry or communicate status of the module. The PC pin is referenced to the –Input pin. All circuits that connect to the PC pin must use the –Input as the reference. Do not break the connection between the –Input and the circuitry connected to the PC pin or damage to the module will result. Additional requirements include:

- Circuits that derive their power from the PC pin must not exceed 1.5 mA.
- Do not drive the PC pin with external circuitry.
- Do not attempt to control the output of the converter by PWM pulsing of the PC pin, or exceed a repetitive on / off rate of 1 Hz.

For applications where the converter will be disabled on a regular basis or where capacitance is added to this pin, please contact [Vicor Applications Engineering](#).

### HIGH-POWER ARRAYS AND PR PIN

To simplify the implementation of large arrays, a subset of modules within the parallel array should be configured as boosters (listeners) by connecting the SC pin to the –S pin. Modules, which are configured as boosters, cannot assume the role of drivers (talkers) for N+M redundant arrays. Modules configured as boosters may be locally sensed.

Each module within the parallel array must be properly bypassed with capacitors. Film or ceramic types should be used across the input of the module and between each input lead and the baseplate. Modules having input sources, which are not connected to SELV sources, should use X-capacitors across the input and Y-capacitors from each input power pin to the baseplate. When in doubt about capacitor safety approvals, always consult with the governing safety regulatory agency or Vicor Applications Engineering.

A maximum of 12 modules may be directly connected in parallel. Please contact Vicor Applications Engineering for assistance with larger arrays.

The PR pin is referenced to the –In pin; therefore, all modules within the array must have a common low-impedance connection between each –In pin. Special precautions are necessary if a PCB is not used for interconnection of modules, because the wiring impedance can be significant. Do not allow the connection between the –In pin and the –In bus to become disconnected as damage to the module will result.

Coupling transformers should be used to transmit the PR pulse if long distances between each module are anticipated or if the interconnection impedance of the –In leads is high or questionable. PR coupling transformer(s) should be used if the PR pulse exits the PCB. For example, an array constructed of multiple circuit cards plugged into a backplane with a number of converters on each card should have a PR coupling transformer at the entry point of each card; however, no coupling transformer would be required between each converter on the card of three or less converters on a single PCB. Do not externally drive the PR pin, connection to this pin is limited to Vicor module application only.

### INPUT SOURCE IMPEDANCE

The impedance of the source feeding the input of the module directly affects both the stability and transient response of the module. In general, the source impedance should be lower than the input impedance of the module by a factor of ten, from DC to 50 kHz.

To calculate the required source impedance, use the following formula:

$$Z = 0.1(V_{LL})^2 / P_{in}$$

where: Z is required input impedance

$V_{LL}$  is the low line input voltage

$P_{in}$  is the input power of the module

Filters, which precede the module, should be well damped to prevent ringing when the input voltage is applied or the load on the output of the module is abruptly changed.

### INPUT TRANSIENTS AND SURGES

The voltage applied to the input of the module must not exceed the ratings outlined in the data sheet. Protection devices such as Zener diodes and MOVs should be used to protect the module from short-duration transients.

These shunt protection devices are effective only if the source impedance is high relative to the impedance of the protection device when it is conducting. For voltage surges where the abnormal voltage is present for a long period of time, shunt protection devices can easily be damaged by the power dissipated. For this type of condition, a voltage limiter in series with the input of the module may be the best solution. Vicor Applications Engineering can assist in recommending the appropriate type of protection for the module.

**NOTE:** Do not allow the rate of change of the input voltage to exceed 10 V/ $\mu$ s for any input voltage deviation.

### SENSE LEADS (Mini and Maxi only)

The sense leads of the module must always terminate either directly to the output pins (local sense) or at the load (remote sense). When remote sense is used, the output wiring impedance in combination with the load impedance can cause significant loss of phase margin and result in oscillation and possible damage to the module, poor transient response, or activation of the output overvoltage protection. Long sense leads may require a compensation circuit for stability.

Protection circuitry is required if the possibility of reversed sense leads can occur. Please contact Vicor Applications Engineering for specific recommendations.

Do **not** exceed 1 V between  $-S$  and  $-Out$  leads. This is an important consideration if the converter is used in a Hot-Swap application. ORing diodes, if used, should be located in the  $+Output$  lead to avoid exceeding this rating.

Do **not** exceed the rated power of the converter. The total of the power consumed by the load plus the power lost in conductors from the converter to the load must be less than the output power rating of the converter.

### OUTPUT CONNECTIONS

For systems designed to charge batteries, subject the module output to dynamic loading, or loads that have large reactive components, please contact Vicor Applications Engineering to discuss your application in detail.

Do **not** externally drive the output of the module 10% above its nominal setpoint voltage.

Modules, that are used to charge batteries should be applied with a diode in series with the output of the module. The charge current must be externally controlled to ensure that the module is not operated in excess of its power or current rating.

Current-carrying conductors should be sized to minimize voltage drops.

Do **not** use output ORing diodes with parallel arrays of the Micro Family converters.

**Output Overvoltage Protection (OVP).** The OVP detection circuitry within the converter is highly resistant to false tripping. For the converter to shut down due to an OVP condition two conditions must be satisfied (logical AND);

1. The voltage at the output terminals must be greater than the OVP set point.
2. The secondary control IC within the converter must be requesting a power conversion cycle from the internal primary control IC.

By using this logic, false tripping of individual converters due to externally induced OVP conditions such as load dumps or, being driven by external voltage sources at the output terminals is minimized. The user should not test the OVP circuit by back driving the output terminals or by any other means as the OVP circuitry is fully tested as part of the inline manufacturing process.

### OVERCURRENT PROTECTION

The Maxi, Mini, Micro converters incorporate a straight-line type current limit. (Figure 3–1) As output current is increased beyond  $I_{max}$ , the output voltage remains constant and within its specified limits up to a point,  $I_{KNEE}$ , which is typically 5 – 25% greater than rated current,  $I_{max}$ . Beyond  $I_{KNEE}$ , the output voltage falls to  $I_{shortcircuit}$ . Typically, modules will automatically recover after the over-current condition is removed.

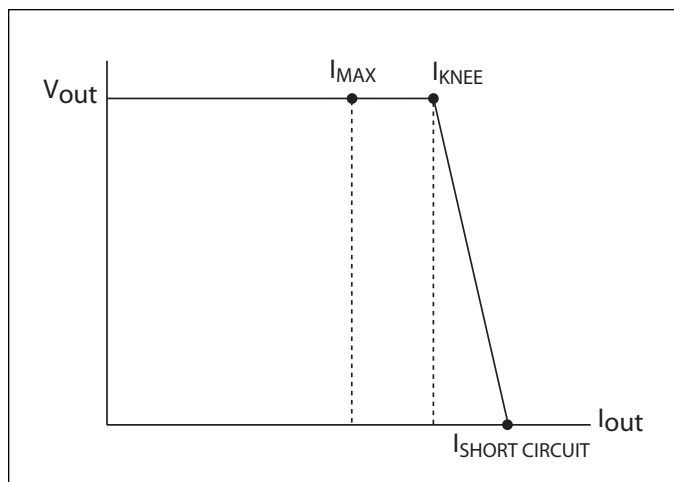

Figure 3-1 — Typical Maxi, Mini, Micro current limiting

### MAXIMUM OUTPUT CAPACITANCE

In general, adding external capacitance to the Maxi, Mini, and Micro's output is not required. However, it is often common practice with power supply designs to add external capacitance to the converter output for attenuation of output ripple and / or improving dynamic load performance. The Maxi, Mini, Micro converters typically have a faster response to dynamic loads than other power solutions; hence, external capacitors may not be necessary. In addition, the output ripple and noise specification listed on the data sheet may be acceptable for many applications.

A general equation for determining the maximum recommended output capacitance is as follows:

$$C_{(\text{farad})} = \frac{\frac{P_{\text{out}}}{V_{\text{out}}} (400 \times 10^{-6})}{V_{\text{out}}}$$

where:  $P_{\text{out}}$  is the output power of the converter  
 $V_{\text{out}}$  is the nominal output voltage of the converter

The capacitance value is not the absolute maximum value, but the value for which general application of the converter can be deemed appropriate. Testing will be required to ensure that the module is stable if this value is exceeded. Approximately 10X the value calculated will cause the converter to go into current limit at turn-on.

**CAUTION:** If exceeding this value, it is recommended that Vicor Applications Engineering be consulted.

### ABSOLUTE MAXIMUM RATINGS

Please consult the latest module data sheets available on the Vicor website for maximum ratings concerning pin-to-pin voltages, isolation, temperature, and mechanical ratings.

### GROUNDING OF BASEPLATE AND REFERENCING OF INPUT AND OUTPUT TERMINALS

The baseplate of the converter should always be connected to earth ground. If for any reason this is not possible in your application please consult with Vicor Applications Engineering for acceptable alternatives for your application.

The input and output leads of the converter should be referenced to the baseplate at some point to avoid stray voltages. For offline applications the input leads are often referenced to earth ground at the AC source ahead of the bridge rectifier. Either + or –Output terminal may be referenced to earth ground and the baseplate. “Floating” inputs or outputs should at a minimum have a high-resistance divider to bleed off stray charges to avoid damage to the insulation system.

### HIGH FREQUENCY BYPASSING

All Vicor converters must be bypassed for proper operation. (Figure 3-2) The minimum complement of high-frequency bypass capacitors must consist of the following:

- 0.2  $\mu\text{F}$  ceramic or film type connected between +In and –In.
- 4.7 nF Y-capacitor between +In and baseplate and –In and baseplate.
- 10 nF ceramic or film capacitor between +Out and baseplate and –Out and baseplate.

All applications utilizing Maxi, Mini, Micro converters should be properly bypassed, even if no EMC standards need to be met. Bypass Vin and Vout pins to each module baseplate as shown in Figure 3-2. Lead length should be as short as possible. Recommended values vary depending on the front end, if any, that is used with the modules, and are indicated on the appropriate data sheet or application note. In most applications, C1 is a 4,700 pF Y-capacitor (Vicor P/N 01000) carrying the appropriate safety agency approval; C2 is a 4,700 pF Y-capacitor (Vicor P/N 01000) or a 0.01  $\mu\text{F}$  ceramic capacitor rated at 500 V. In PC board applications, each of these components is typically small enough to fit under the module baseplate flange. For PCB mounting of the module. Please refer to Figures 3-3 and 3-4.

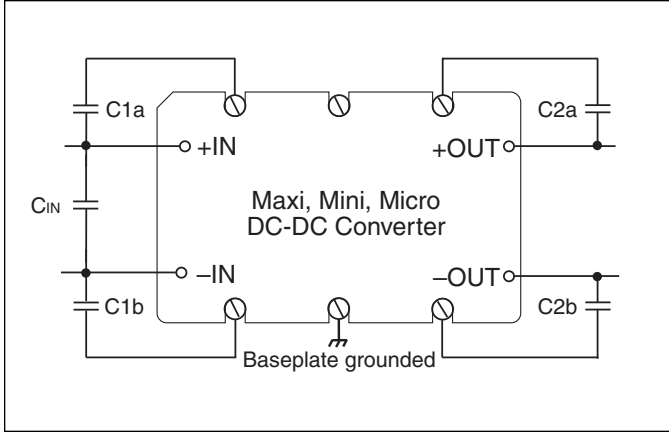

**Figure 3-2** — Minimum recommended bypassing for Maxi, Mini, and Micro; Keep all leads short.

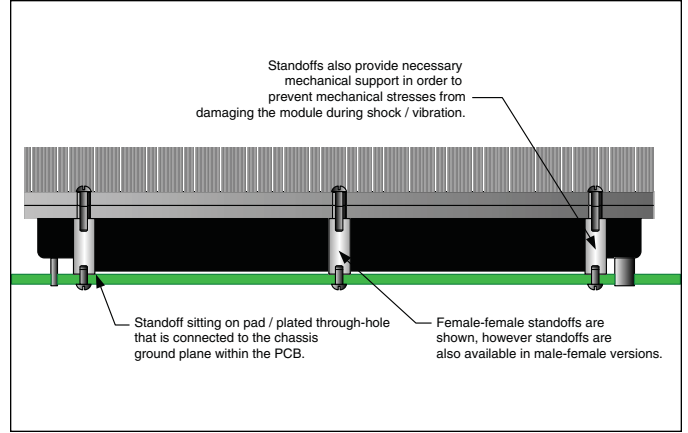

**Figure 3-3** — Recommended mounting method using standoffs

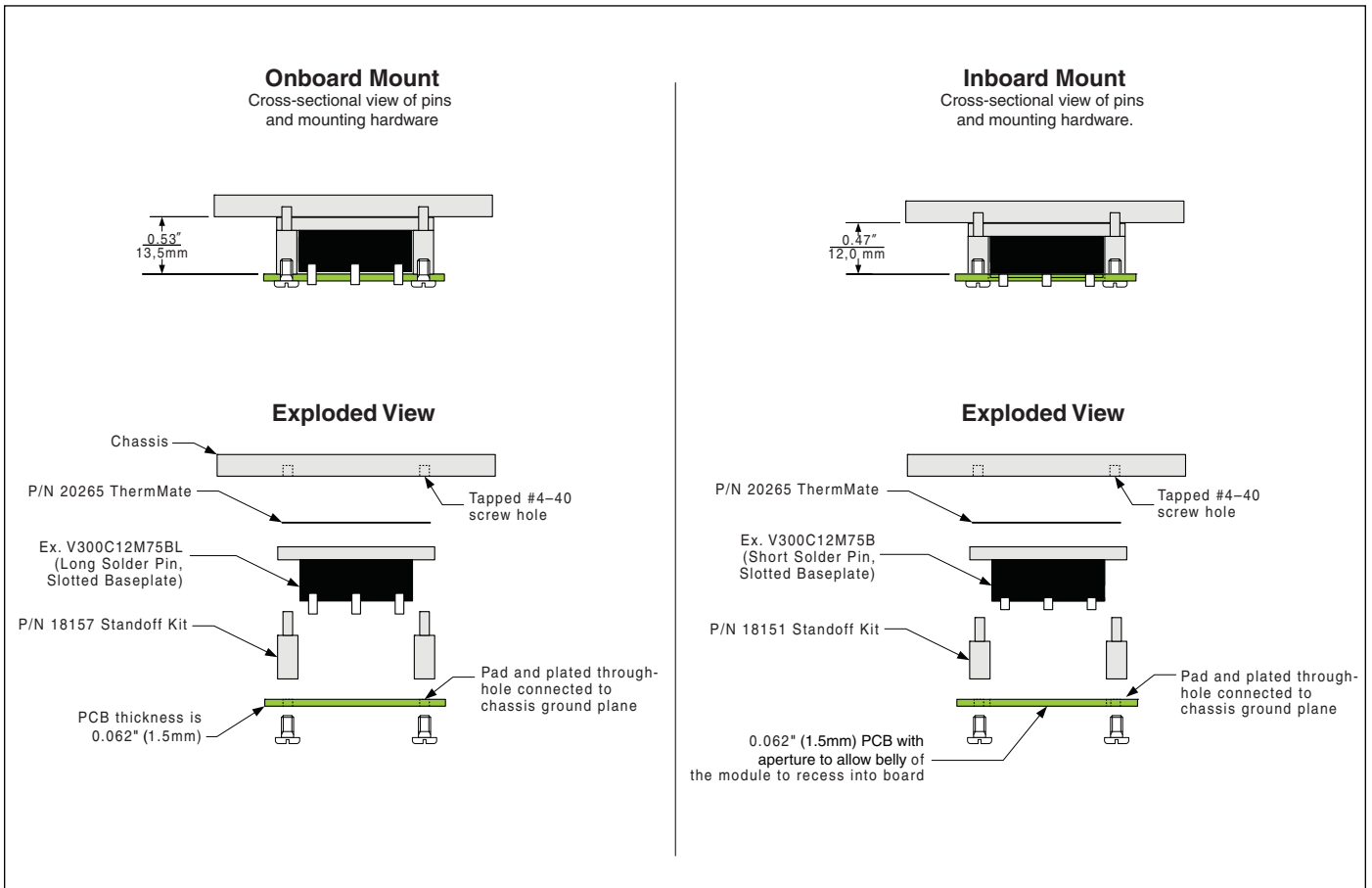

**Figure 3-4** — Onboard vs. inboard mounting of (1/4 brick) Micro with slotted baseplate

## FILTERING AND TRANSIENT PROTECTION

All switching power supplies generate potentially interfering signals as a result of high-frequency, high-power switching. The Vicor power converter topology, to a large extent, addresses the problem at the source by the use of a quasi-resonant, zero-current switching (ZCS) and zero-voltage switching (ZVS) topology. The switching current waveform is a half sine wave that generates far less conducted and radiated noise in both frequency spectrum and magnitude. EMI filtering, if properly designed and implemented, reduce the magnitude of conducted noise an additional 40 – 60 dB, and as a result, the noise radiated by the power conductors is reduced proportionally.

Conducted noise on the input power lines can occur as either differential-mode or common-mode noise currents. Differential-mode noise, largely at low frequencies, appears across the input conductors at the fundamental switching frequency and its harmonics. Common-mode noise, which has mostly high-frequency content, is measured between the converter's input conductors and ground.

The Vicor power converter being an electronic device may be susceptible to high levels of conducted or radiated emissions. It is the responsibility of the user to assess testing protocols in order to determine applicability of the converter in the intended application.

## BASIC GUIDELINES FOR SUCCESSFUL EMI FILTERING

1. Keep current loops small. The ability of a conductor to couple energy by induction and radiation is reduced accordingly.
2. For conductor pairs, use wide (low Z) copper traces aligned above and below each other.
3. Locate filters at the source of interference; i.e., close to the power converter(s).
4. Filter component values should be chosen with consideration given to the desired frequency range of attenuation. For example, capacitors are self-resonant at a certain frequency, beyond which they look inductive. Keep bypass capacitor leads as short as possible.
5. Locate components on the PCB with consideration given to proximity of noise sources to potentially susceptible circuits. For example, the FIAM is an input line filter module that has been optimized for use with Maxi, Mini, and Micro DC-DC converters. When used in conjunction with the recommended external components and layout, it will significantly reduce the differential and common-mode noise returned to the power source. The FIAM meets the requirements of EN55022 "B", FCC "B", and Bellcore GR-001089-CORE, Issue 2 when used with any combination of Maxi, Mini, and Micro converters up to the FIAM's maximum rated current.

DC-DC converter inputs and outputs must be properly bypassed, to system chassis or earth. Bypass Vin and Vout pins to each DC-DC module baseplate. Capacitor lead length must be as short as possible. (Figure 4–1)

EMI filtering can be application dependent. A packaged filter module may not always be the appropriate solution, and the general practice of bypassing Vin and Vout may not produce optimal results. You may have to adjust the values depending on the severity of common-mode and differential-mode noise. (Figures 4–2 and 4–3)

Input transient suppression should be used in applications where source transients may be induced by load changes, blown fuses, etc. The level of transient suppression required will depend on the expected severity of the transients. A Zener diode, TRANSORB™, or MOV will provide transient suppression, act as a voltage clamp for DC input spikes, and provide reverse input voltage protection. The device voltage rating should be chosen above high-line voltage limits to avoid conducting during normal operation which would result in overheating.

Module shields that provide shielding around the belly (label side) of the Maxi, Mini, Micro are also available for applications that are highly noise sensitive. Module shield information is available on the Vicor website, see links provided, on the following page.

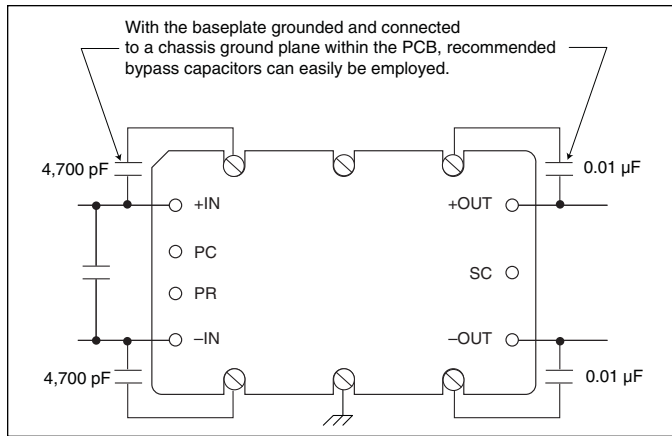

**Figure 4-1** — Recommended bypassing capacitors must be in close proximity, i.e., have short lead length to be effective.

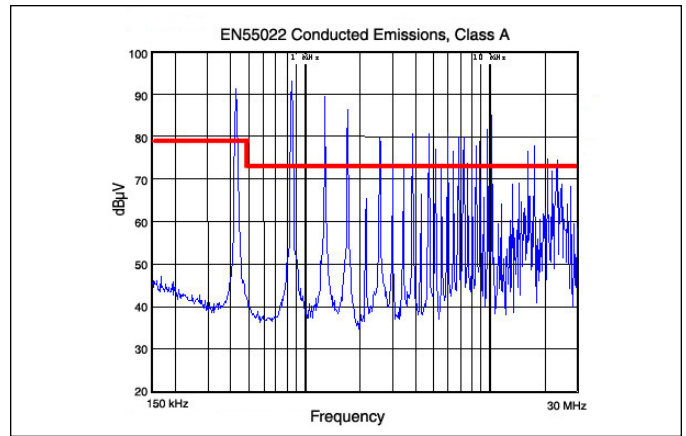

**Figure 4-2** — V48B28H250BN without bypass caps (330 μF across input)

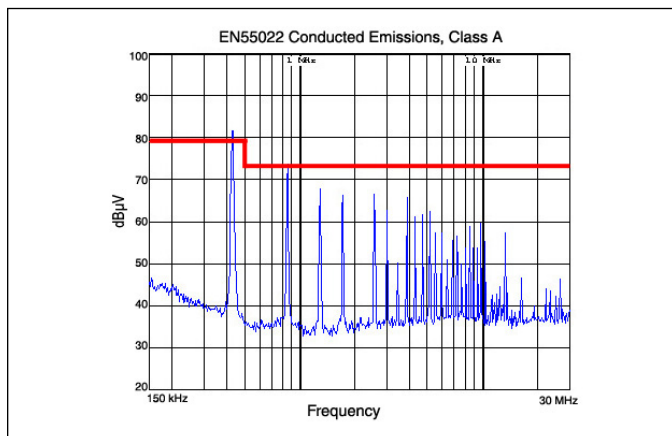

**Figure 4-3** — V48B28H250BN with recommended bypass caps (330 μF across input)

### Module Shield Information

Module shield for Maxi with threaded or through-hole baseplate P/N 30142

<http://vdac2.vicr.com/CADPDF/H7CEX3.PDF>

Module shield for Maxi with slotted baseplate P/N 30199

<http://vdac2.vicr.com/CADPDF/HXE113.PDF>

Module shield for Mini with threaded or through-hole baseplate P/N 30180

<http://vdac2.vicr.com/CADPDF/UT55TT.PDF>

Module shield for Mini with slotted baseplate P/N 30198

<http://vdac2.vicr.com/CADPDF/HXE112.PDF>

Module shield for Micro with threaded or through-hole baseplate P/N 30143

<http://vdac2.vicr.com/CADPDF/9YRD8X.PDF>

Module shield for Micro with slotted baseplate P/N 30141

<http://vdac2.vicr.com/CADPDF/NG6SIS.PDF>

Whenever power supplies or converters are operated in a parallel configuration — whether for higher output power, fault tolerance, or both — current sharing is an important consideration. Most current-sharing schemes employed with power converters involve either artificially increasing the output impedance of the converter module or actually sensing each output current, forcing all of the currents to be equal by feedback control. In a synchronous current-sharing scheme, however, there is no need for having a current-sensing or current-measuring device on each module, nor is there a need to artificially increase the output impedance, which compromises load regulation.

### WHY IS CURRENT SHARING IMPORTANT

Most paralleled power components — transistors, rectifiers, power conversion modules, offline power supplies — will not inherently share the load. In the case of power converters, one or more of the converters will try to assume a disproportionate or excessive fraction of the load unless forced current-share control is designed into the system. One converter — typically the one with the highest output voltage — may deliver current up to its current limit setting, which is beyond its rated maximum. Then the voltage will drop to the point where another converter in the array — the one with the next highest voltage — will begin to deliver current. All of the converters in an array may deliver some current, but the load will be shared unequally. Built-in current limiting may cause all or most converters to deliver current, but the loading will remain unbalanced, and potentially cause damage to the converters.

Consider the situation when one module in a two-module array is providing all of the load. If it fails, the load on the second module must go from no load to full load, during which time the output voltage is likely to droop temporarily. This could result in system problems, including shutdown or reset. If both modules were sharing the load and one failed, however, the surviving module would experience a much less severe transient (one half to full load), and the output voltage would be likely to experience no more than a slight momentary droop. The dynamic response characteristic of all forward converters, resonant or pulse-width modulated, is degraded when the load is stepped from zero (no load) where the output inductor current is discontinuous.

In the same two-module array example, the module carrying all of the load is also generating all of the heat, resulting in a much lower mean time between failure (MTBF) for that module. An often-quoted rule of thumb says that for each 10°C increase in operating temperature, average component life is cut in half. In a current-sharing system, all of the converters or supplies

run at a lower temperature than some modules would in a system without current sharing. As a result, all of the modules age equally.

Current sharing, then, is important because it improves system performance; it minimizes transient / dynamic response and thermal problems and improves reliability. It is an essential ingredient in most systems that use multiple power supplies or converters for higher output power or for fault tolerance.

### CURRENT-SHARING IN POWER EXPANSION ARRAYS

When parallel supplies or converters are used to increase power, current sharing is achieved by a number of approaches. One scheme simply adds resistance in series with the load. A more practical variant of that is the “droop-share” method, which actively causes the output voltage to drop in response to increasing load. The two most commonly used approaches to paralleling converters for power expansion are the driver / booster or master / slave arrays and analog current-share control. They appear to be similar, but the implementation of each is quite different. Driver / booster arrays usually contain one intelligent module or driver, and one or more power-train-only modules or boosters. Analog current-share control involves paralleling two or more identical modules, each containing intelligence.

**Droop Share.** The droop-share method, shown in Figure 5–1, increases the output impedance to force the currents to be equal. It is accomplished by an error signal, which is interjected into the control loop of the converter causing the output voltage to operate as a function of load current. As load current increases, output voltage decreases. All of the modules will have approximately the same amount of current because they are all being summed into one node. If one supply is delivering more current than another supply, its output voltage will be forced down a little so that it will be delivering equal current for an equal voltage out of that summing node. Figure 5–1 illustrates a simple implementation of this scheme where the voltage dropped across the ORing diode, being proportional to current, is used to adjust the output voltage of the associated converter.

Droop share has advantages and disadvantages. One of the advantages is that it can work with any topology. It is also fairly simple and inexpensive to implement. A major drawback, though, is that it requires that the current be sensed. A current-sensing device is needed in each of the converters or power supplies. In addition, a small penalty is paid in load regulation, although in many applications this is not an issue.

In general, it is not recommended to mix and match converters, especially those with incompatible current-sharing schemes. The droop-share method, however, is more forgiving in this regard than with any of the other methods. Current sharing can be achieved using arrays constructed from different converter models or even from different suppliers with a little external circuitry.

**Driver/ Booster Arrays.** Most Vicor converters can employ the driver / booster array for increased power. (Figure 5–2) Driver / booster arrays usually contain one intelligent module or driver, and one or more power-train-only modules or boosters. The driver is used to set and control output voltage, while booster modules are used to increase output power to meet system requirements.

Driver / booster arrays of quasi-resonant converters with identical power trains inherently current share because the per-pulse energy of each converter is the same. If the inputs and outputs are tied together and the units have the same clock frequency, all modules will deliver the same current (within component tolerances). The single intelligent module in the array determines the transient response, which does not change as modules are added. Booster modules require only one connection between units when their outputs are connected; no trimming, adjustments, or external components are required to achieve load sharing. The load sharing is dynamic and usually guaranteed to be within five percent.

It is important to remember that when using boosters, the input voltage, output voltage, and output power of the boosters must be the same as the driver.

The advantages of driver / booster arrays are that they have only a single control loop so there are no loop-within-a-loop stability issues, and they have excellent transient response. However, this arrangement is not fault tolerant. If the driver module fails, the array will fail to maintain its output voltage.

**Analog Current-Share Control.** Analog current-share control, typical of PWM type converters, involves paralleling two or more identical modules, each containing intelligence. The circuit actively adjusts the output voltage of each supply so that the multiple supplies deliver equal currents. This method, however, has a number of disadvantages. Each converter in the array has its own voltage regulation loop, and each requires a current sensing device and current control loop.

Analog current-share control supports a level of redundancy, but it is susceptible to single-point failures within the current-share bus that can, at best, defeat current sharing, and, at worst, destroy every module in the array. The major reason for this is the single-wire galvanic connection between modules.

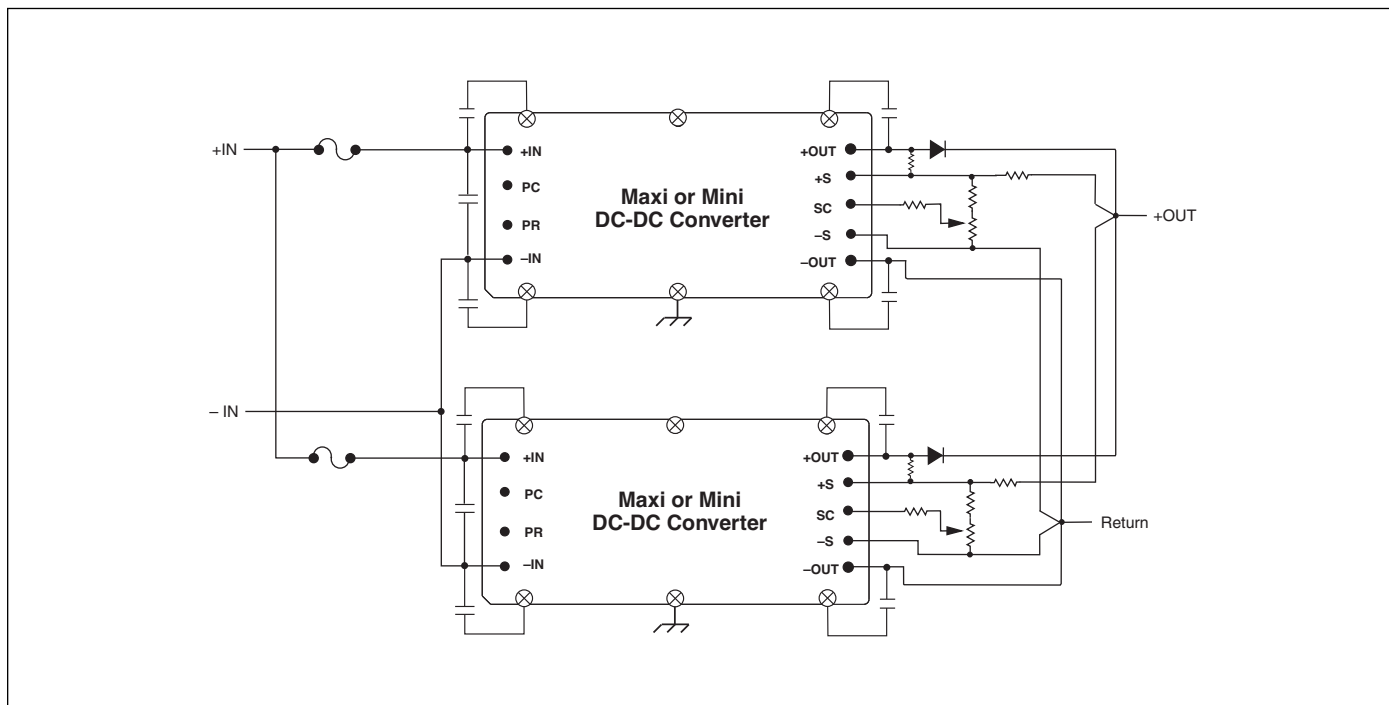

Figure 5–1 — The droop-share method artificially increases the output impedance to force the currents to be equal.

### CURRENT SHARING IN FAULT TOLERANT ARRAYS

Current sharing is an essential element in fault-tolerant arrays, and regardless of the approach, there is an inherent additional cost incurred by the addition of at least one redundant converter or supply.

Most applications today that require fault tolerance or redundancy also require Hot-Swap capability to ensure continuous system operation. Hot swappable cards must be designed so that the operator cannot come in contact with dangerous potentials, currents or thermal hazards. It is also essential that when a module fails, the failure is detected and identified by an alarm or notice to provide service. A Hot-Swap system must ensure that during swap out there is minimal disturbance of the power bus. Specifically, the affected voltage bus must not drop enough to cause errors in the system, either on the input bus or the output bus.

**N+1 Redundancy.** A power supply failure can cripple an entire system, so a redundant converter or supply can be added to ensure that, in the event of a failure, the system will continue to operate. Adding an extra module (N+1) to a group of paralleled modules will significantly increase reliability with only a modest increase in cost.

How redundant converters are implemented is determined in part by the available space and cost requirements. Two 500 W Maxi modules, for example, could be used to provide a 1 kW output with an additional 500 W module for 2+1 redundancy a total of 1.5 kW in a volume of about 16.5 in<sup>3</sup> (270 cm<sup>3</sup>). Four 200 W half-size modules might be used instead with a fifth 200 W module for 4+1 redundancy, a total of 1 kW and 14 in<sup>3</sup> (229 cm<sup>3</sup>). Although the second solution uses less space, it increases the accumulated failure rate because it employs more converters, more ORing diodes, more monitoring circuitry, and more assembly.

ORing diodes may be inserted in series with the +Output of each module in a N+1 array to provide output fault tolerance (Figure 5–1). They are important in a redundant power system to maintain fault isolation. Without them, a short-circuit failure in the output of one converter could bring down the entire array. As well, fusing the input of each converter prevents a converter input short from compromising the entire array.

ORing diodes, however, add losses to the power system, reducing overall efficiency (and, potentially, decreasing reliability). To ameliorate this negative effect on efficiency, ORing diodes should run hot, thereby reducing forward voltage drop and improving system efficiency. Reverse leakage current will be an issue only if the output of a converter shorts and the diode is reverse biased. This is an important consideration with regard to operating temperature.

Current sharing, required to ensure system reliability, can be implemented by a multiplicity of methods. Figure 5–1, shown earlier as an example of the droop-share method, is also an example of N+1 redundancy using ORing diodes.

**Synchronous Current Sharing.** Synchronous current sharing (Figure 5–2) is available with Maxi, Mini, Micro converters — converters that use the zero-current-switching and zero-voltage-switching topology. Each module has the capability to assume control of the array, that is, they constitute a democratic array. The module that assumes command transmits a pulse on the parallel bus to which all other modules on the bus synchronize.

The converters use this pulse as a current-sharing signal for power expansion and fault-tolerant applications. The pulsed signal on the parallel bus simplifies current-sharing control by synchronizing the high-frequency switching of each converter. The parallel pin is a bi-directional port on each module used to transmit and receive information between modules. If the lead module relinquishes control, another module in the array will transparently take command with little or no perturbation of the output bus. A pulsed signal also gives designers the option to add capacitors (Figure 5–3) or transformers between parallel pins, providing DC-blocked coupling. Such coupling prevents certain failure modes internal to a single module from affecting the other modules in the array, thus providing an increased level of fault tolerance.

Use of a current-share bus transformer (Figure 5–4) enables arrays of Maxi, Mini, Micro converters to current share when they are widely separated or operated from independent sources. Since the current-share signal is a pulsed signal, it can be transformer coupled. Transformer coupling this pulsed signal provides a high level of common-mode noise immunity while maintaining SELV isolation from the primary source. This is especially useful when board-to-board load sharing is required in redundant applications.

Synchronous current sharing eliminates the need for current-sensing or current-measuring devices on each module, and load regulation is not compromised. Additional advantages of the synchronous current sharing architecture includes excellent transient response, “no loop within a loop” control problems, and, a high degree of immunity from system noise. The availability of synchronous current sharing in democratically controlled arrays offers power architects new opportunities to achieve simple, non-dissipative current-share control. It provides options that simplify current sharing and eliminates the tradeoffs — such as the need to sense the current from each individual module and adjust each control voltage — as is the case with other current-sharing methods.

The synchronous current-sharing method applies to quasi-resonant, frequency-modulated converters with the necessary intelligence, such as the Vicor Maxi, Mini, Micro Family of high-density DC-DC converters, where the energy per pulse is fixed.

Finally, no matter what method is used, current sharing reduces thermal problems, improves transient response, and helps extend the lifetimes of all modules in an array. Nevertheless, all current-sharing schemes require careful attention to electrical and mechanical design to operate effectively.

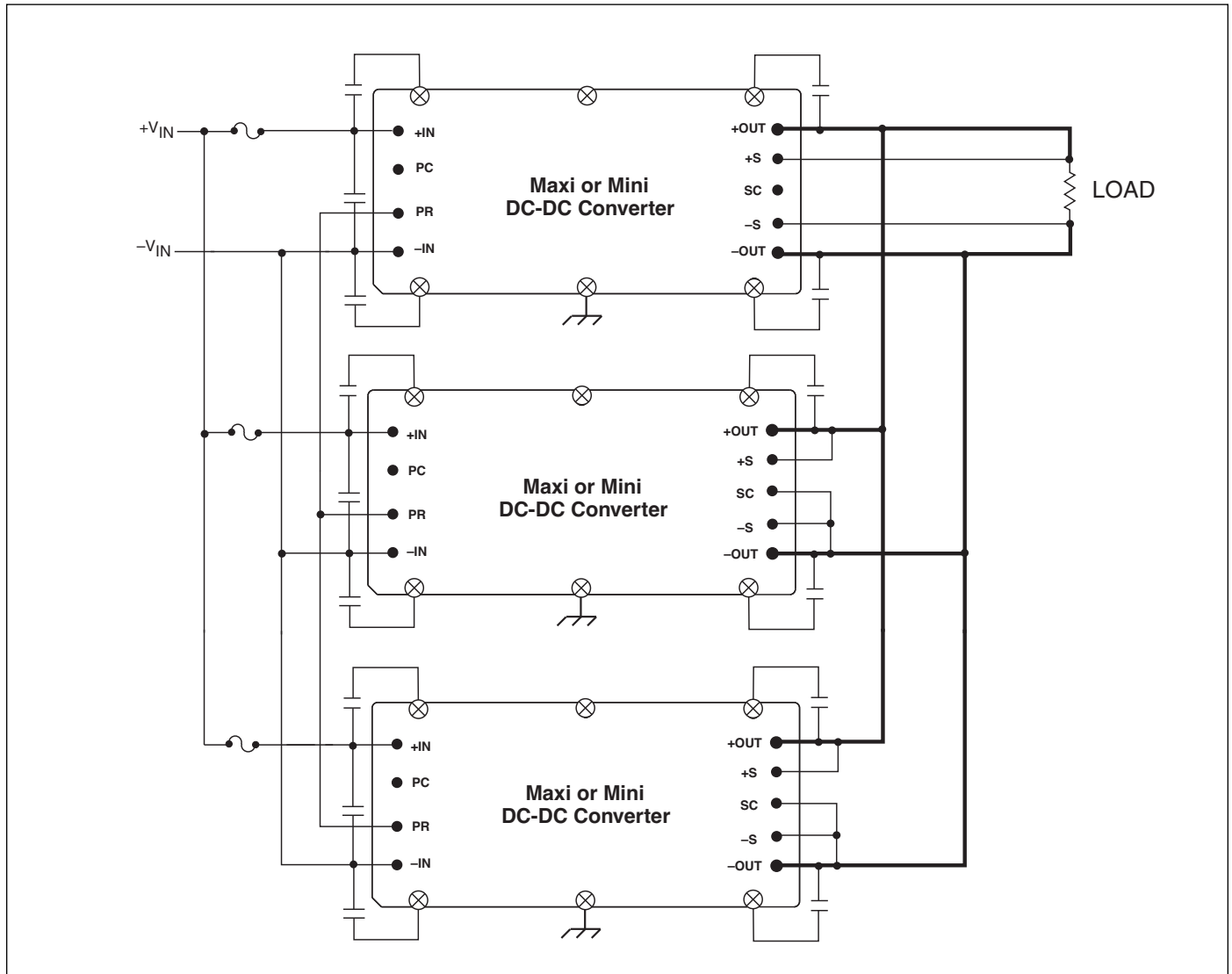

**Figure 5-2** — PCB mounted DC-DC array with dedicated boosters for output power expansion. Shorting SC to -S sets converter as a dedicated booster.

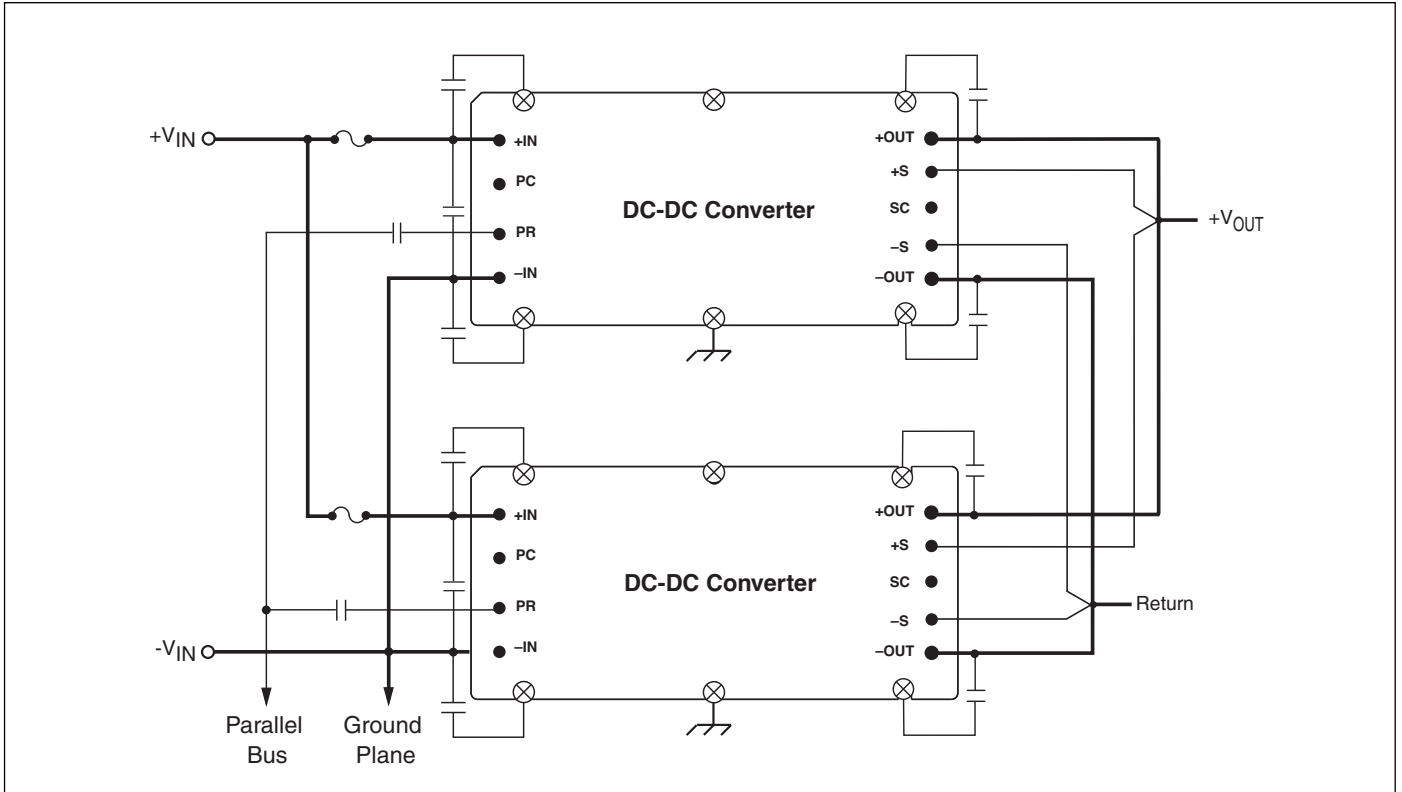

Figure 5-3 — Synchronous power architecture simplifies current sharing control and enhances fault tolerance.

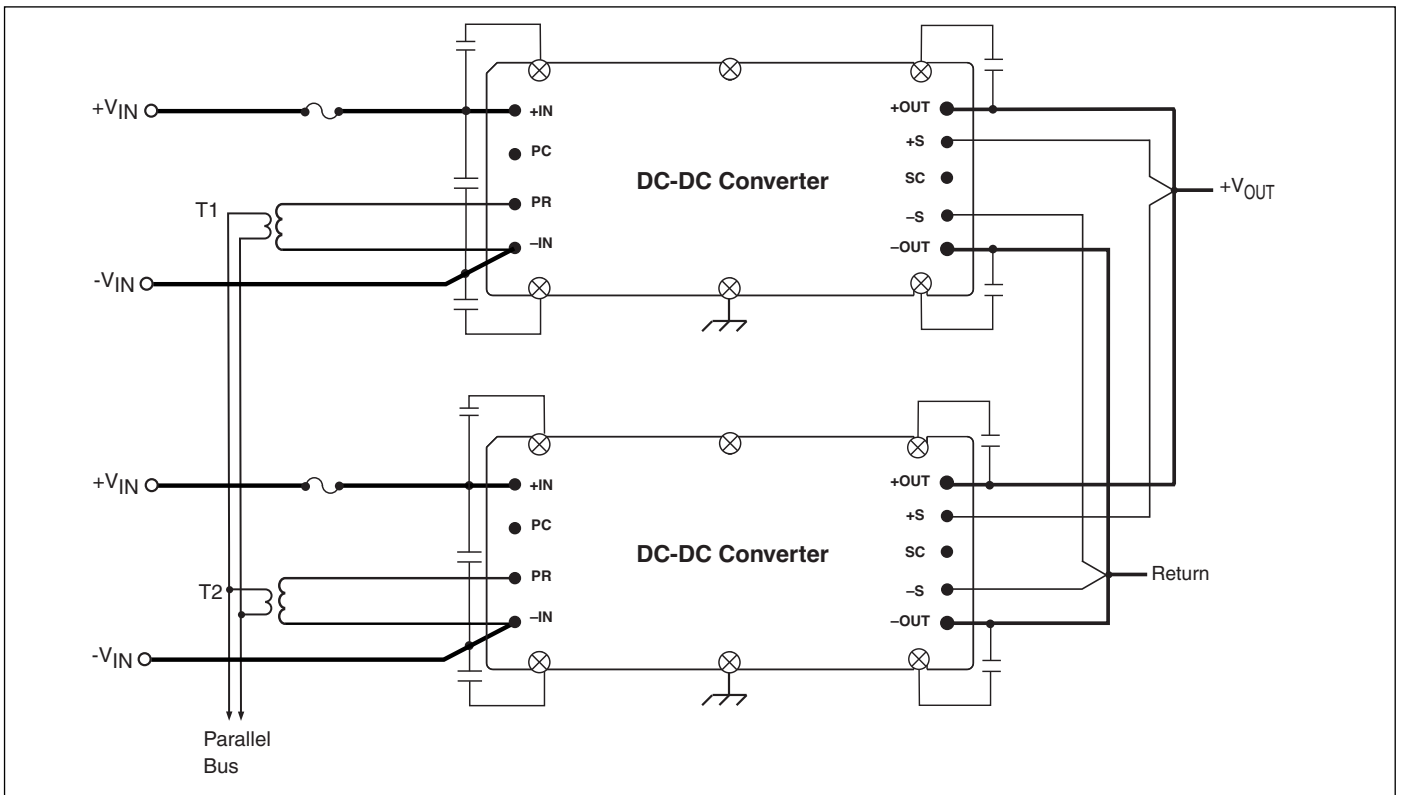

Figure 5-4 — Transformer-coupled interface provides load sharing and SELV isolation from the primary source.

Simplified thermal management is one of the benefits of using Vicor converters. High operating efficiency minimizes heat loss, and the low-profile package features an easily accessible, electrically isolated thermal interface surface.

Proper thermal management pays dividends in terms of improved converter and system MTBFs, smaller size, and lower product life-cycle costs. The following pages provide guidelines for achieving effective thermal management of Vicor converters.

Consideration should be given to the module baseplate temperature during operation. The maximum baseplate temperature specification for Maxi, Mini, and Micro is 100°C.

Enhanced module cooling can be achieved with free or forced convection by using the appropriate heat sink. The available [Vicor heat sinks and thermal interface options](#) are available on the Vicor website.

The relevant nomenclature for the tabulated thermal information supplied in this section for the Maxi, Mini, and Micro modules is defined as follows:

$T_b$  = baseplate temperature

$T_a$  = ambient temperature

$P_{out}$  = module output power

$P_{in}$  = module input power

$\eta$  = module efficiency =  $P_{out} / P_{in}$

$P_{diss}$  = module power dissipation =  $P_{in} - P_{out} = (1/\eta - 1) \cdot P_{out}$

Supplied thermal resistance values:

$\theta_{bs}$  = baseplate-to-heatsink thermal resistance

$\theta_{ba}$  = baseplate-to-ambient thermal resistance

Basis of output power versus ambient temperature derating curves:

$(T_a)_{max} = (T_b)_{max} - \theta_{ba} \cdot P_{diss} = (T_b)_{max} - \theta_{ba} \cdot (1/\eta - 1) \cdot P_{out}$

#### Additional Thermal Data

The following pages contain temperature derating curves.  
For additional thermal data, see the following link:

[www.vicorpower.com/support/technical/apps-info/xls/calc\\_t~1.xls](http://www.vicorpower.com/support/technical/apps-info/xls/calc_t~1.xls)

**THERMAL PERFORMANCE CURVES (Maxi)**

**Table Usage:** The forced convection thermal impedance data shown in the tables on the next three pages assumes airflow through the heat sink fins. Actual airflow through the fins should be verified. For purposes of heat sink calculation, assume efficiencies listed on Maxi data sheets. Use as a design guide only. Verify final design by actual temperature measurement.

Maxi $\theta_{ba}$ (Baseplate-to-Ambient Thermal Resistance Values) vs. Airflow						
$\theta_{bs} = 0.07^\circ\text{C/W}$	Baseplate	0.9" Longitudinal Fins	0.9" Transverse Fins	0.4" Longitudinal Fins	0.4" Transverse Fins	
Free Air	4.98	2.89	2.24	3.72	3.49	
200 LFM	3.23	1.30	1.02	2.14	1.53	
400 LFM	2.17	0.90	0.72	1.48	1.08	
600 LFM	1.73	0.72	0.60	1.10	0.87	
800 LFM	1.46	0.59	0.51	0.86	0.70	
1,000 LFM	1.27	0.51	0.44	0.71	0.60	
1,200 LFM	1.14	0.46	0.41	0.61	0.55	

**Maxi Output Power vs. Ambient Temperature Derating Curves**

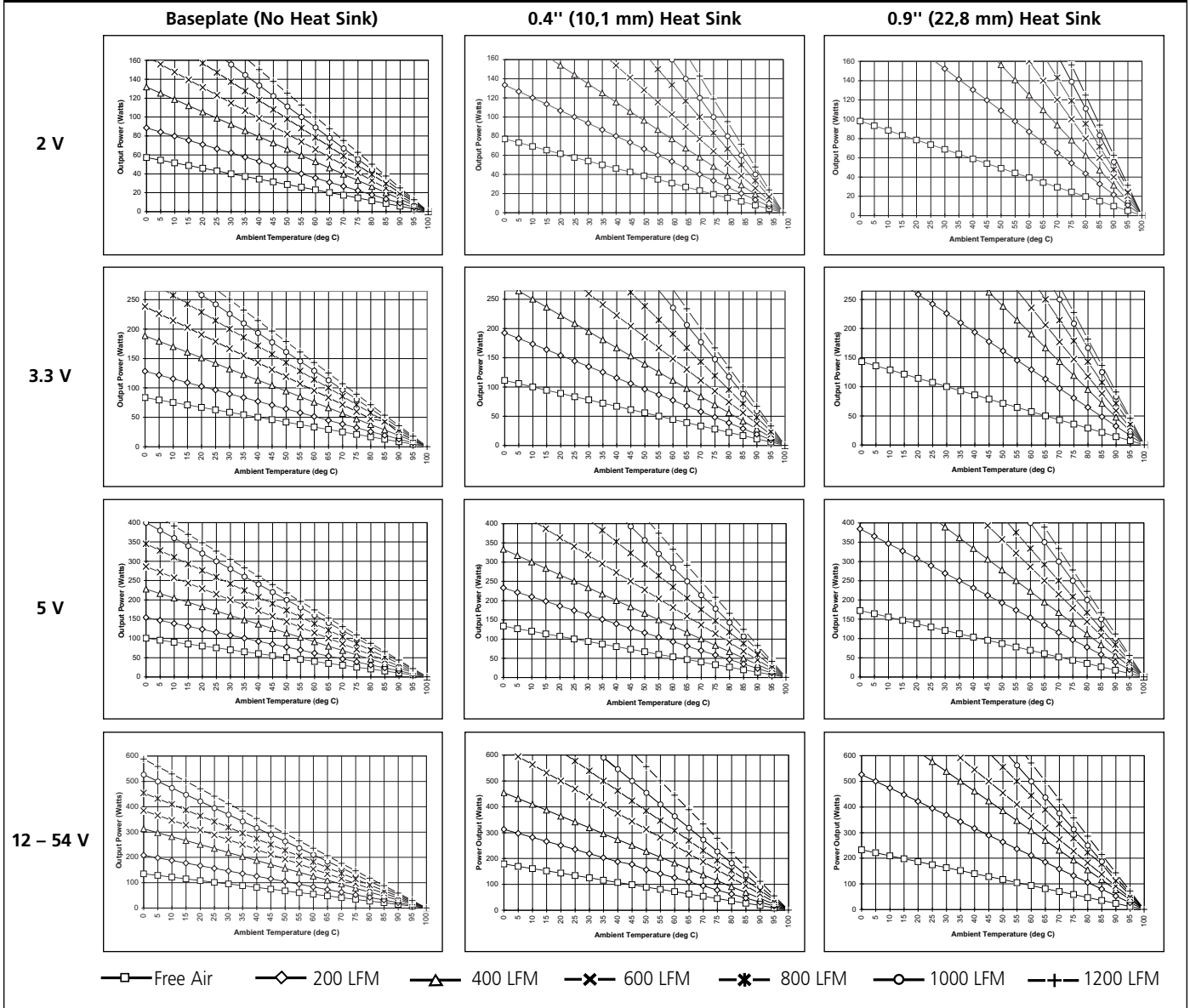

**THERMAL PERFORMANCE CURVES (Mini)**

**Table Usage:** The forced convection thermal impedance data shown in the tables on the next three pages assumes airflow through the heat sink fins. Actual airflow through the fins should be verified. For purposes of heat sink calculation, assume efficiencies listed on Mini data sheets. Use as a design guide only. Verify final design by actual temperature measurement.

Mini $\theta_{ba}$ (Baseplate-to-Ambient Thermal Resistance Values) vs. Airflow						
$\theta_{bs} = 0.14^{\circ}\text{C/W}$	Baseplate	0.9" Longitudinal Fins	0.9" Transverse Fins	0.4" Longitudinal Fins	0.4" Transverse Fins	
Free Air	7.94	4.10	3.93	6.28	6.34	
200 LFM	4.50	1.72	1.93	2.81	3.00	
400 LFM	3.20	1.26	1.38	1.98	2.09	
600 LFM	2.52	1.02	1.06	1.55	1.59	
800 LFM	2.15	0.86	0.89	1.24	1.31	
1,000 LFM	1.89	0.75	0.77	1.05	1.11	
1,200 LFM	1.69	0.68	0.70	0.94	0.99	

**Mini Output Power vs. Ambient Temperature Derating Curves**

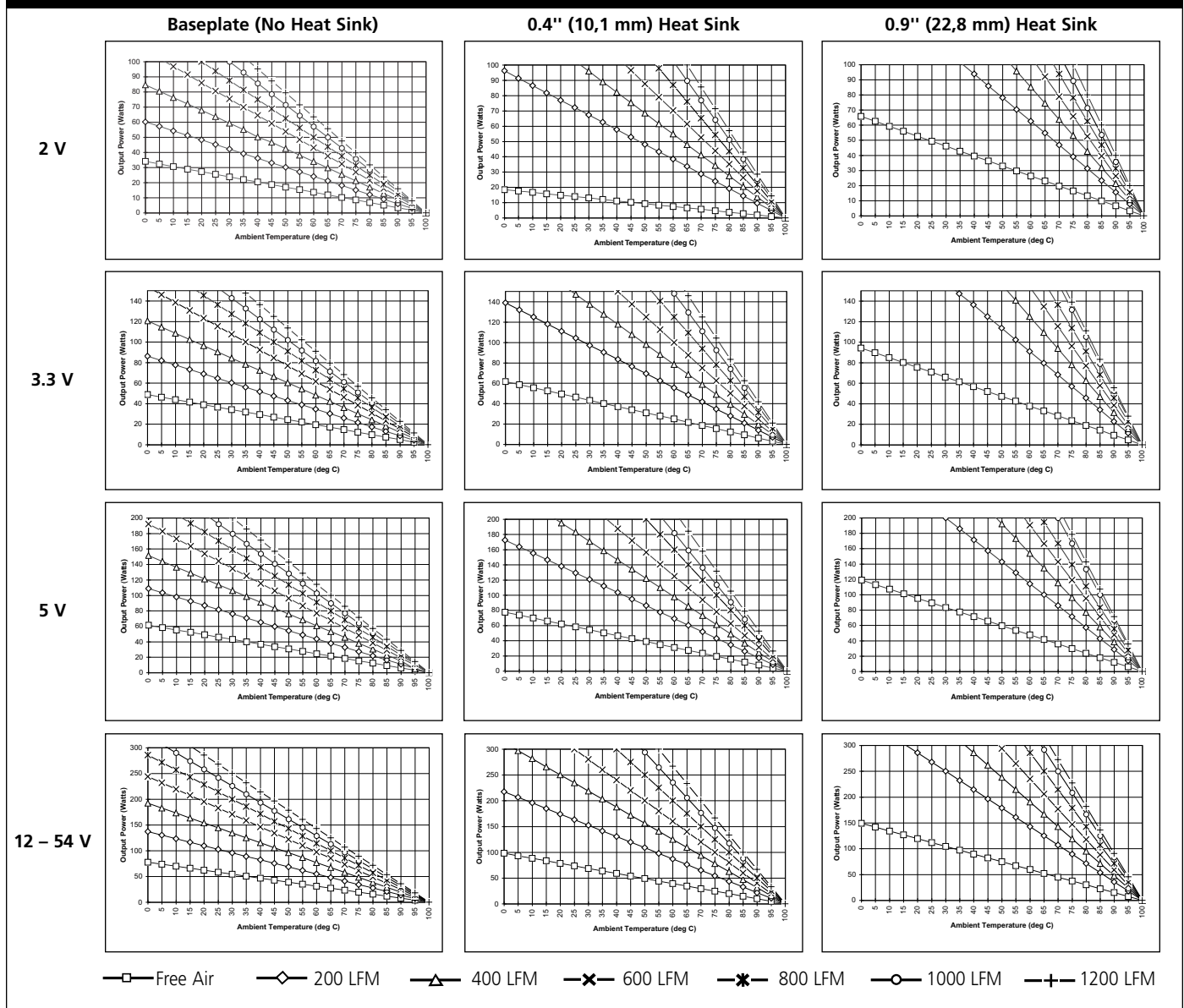

**THERMAL PERFORMANCE CURVES (Micro)**

**Table Usage:** The forced convection thermal impedance data shown in the tables on the next three pages assumes airflow through the heat sink fins. Actual airflow through the fins should be verified. For purposes of heat sink calculation, assume efficiencies listed on Micro data sheets. Use as a design guide only. Verify final design by actual temperature measurement.

Micro $\theta_{ba}$ (Baseplate-to-Ambient Thermal Resistance Values) vs. Airflow						
$\theta_{bs} = 0.21^\circ\text{C/W}$	Baseplate	0.9" Longitudinal Fins	0.9" Transverse Fins	0.4" Longitudinal Fins	0.4" Transverse Fins	
Free Air	10.90	5.37	5.04	7.77	7.76	
200 LFM	6.90	2.51	2.31	3.87	3.58	
400 LFM	4.78	1.79	1.68	2.68	2.52	
600 LFM	3.74	1.42	1.31	2.13	2.01	
800 LFM	3.15	1.20	1.10	1.78	1.67	
1,000 LFM	2.79	1.06	0.97	1.48	1.45	
1,200 LFM	2.49	0.93	0.88	1.32	1.29	

**Micro Output Power vs. Ambient Temperature Derating Curves**

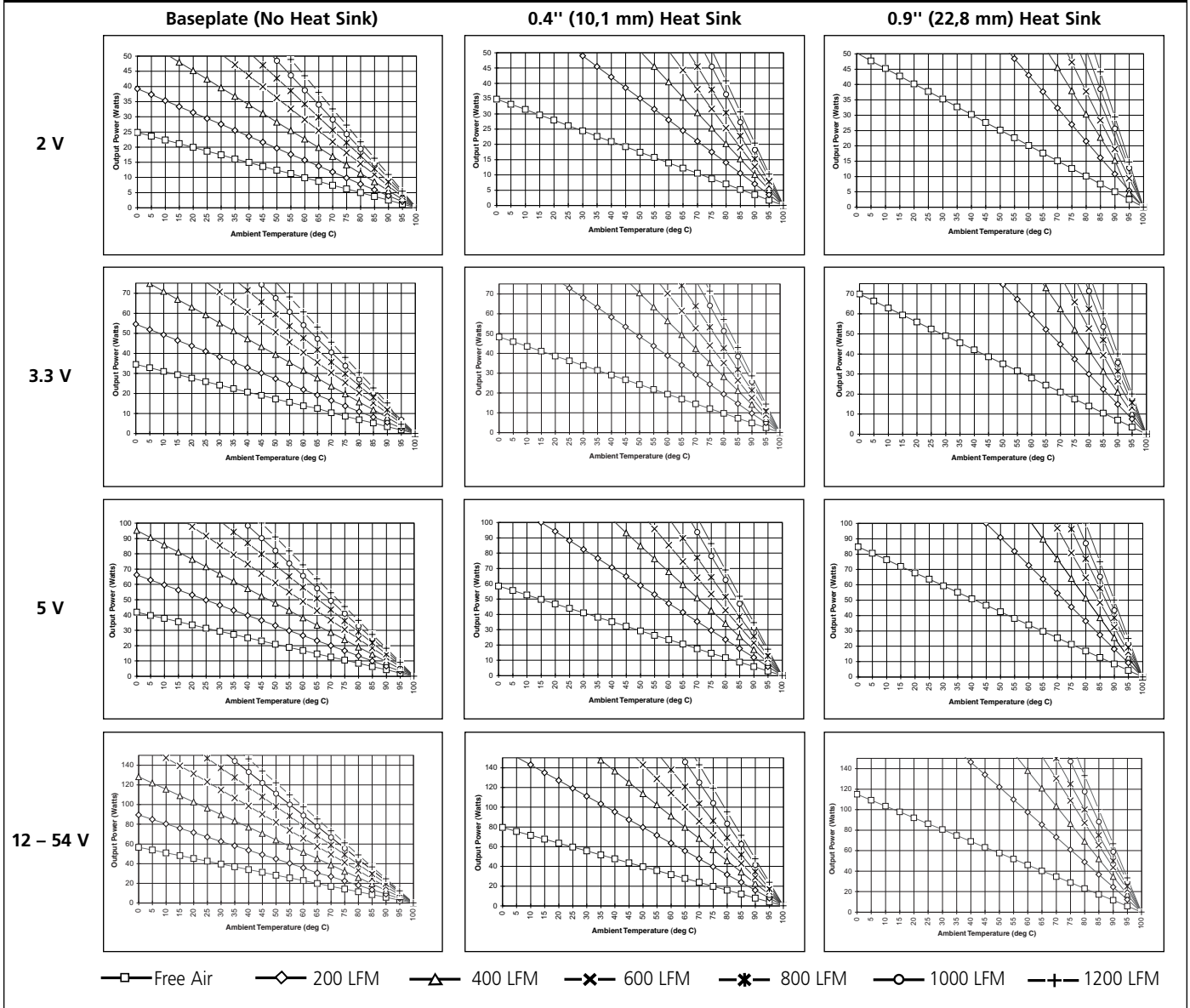

**Typical Examples — Thermal Equations (Maxi, Mini, Micro)**

**EXAMPLE 1**

Determine the maximum output power for a Maxi module without a heat sink delivering 5 V in 400 LFM airflow at a maximum ambient temperature of 40°C.

$$\text{Maximum output power} = (T_{b_{\max}} - T_{a_{\max}}) / [\theta_{ba} \cdot (1/\eta - 1)]$$

$$T_{b_{\max}} = 100^{\circ}\text{C}$$

$$T_{a_{\max}} = 40^{\circ}\text{C}$$

For Maxi module without a heat sink @ 400 LFM,  $\theta_{ba} = 2.17^{\circ}\text{C/W}$

For the 5 V Maxi module the typical value for  $\eta = 0.83$

$$\text{Maximum output power} = (100 - 40) / [2.17 (1/0.83 - 1)] \sim 135 \text{ W}$$

Or, the same answer could be obtained by using the output power versus ambient temperature derating curves for the Maxi modules.

For the case with no heat sink the baseplate chart for the 5 V module would be used. At a 40°C ambient and 400 LFM airflow this chart indicates a maximum output power of approximately 135 W.

For full output power of 400 W the required thermal resistance is;

$$\theta_{ba} = (100 - 40) / [400 (1/0.83 - 1)] = 0.73^{\circ}\text{C/W}$$

What size heat sink would be necessary to operate at full output power (400 W) under the same conditions?

From the  $\theta_{ba}$  versus airflow charts for the Maxi, the thermal resistance at 400 LFM airflow requires the use of a 0.9" (22,8 mm) transverse fin heat sink.

**EXAMPLE 2**



Determine the maximum ambient for a Mini module with a 0.9" (22,8 mm) heat sink in 400 LFM of airflow delivering 200 W at 5 V.

From the output power versus ambient temperature chart for the 5 Vout Mini with a 0.9" (22,8 mm) heat sink, the 200 W at 400 LFM data point results in a  $T_{a_{\max}}$  of approximately 48°C.

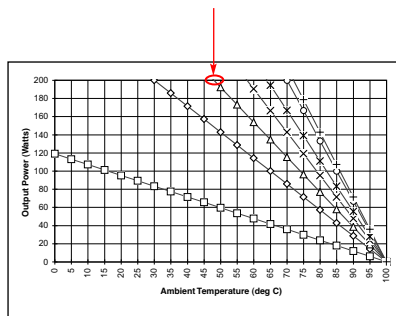
5 V Mini with  
0.9" (22,8 mm)  
heat sink

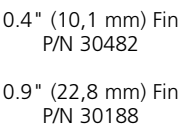
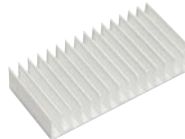
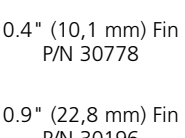

**THERMAL MANAGEMENT ACCESSORIES (All parts are RoHS compliant unless otherwise noted)**

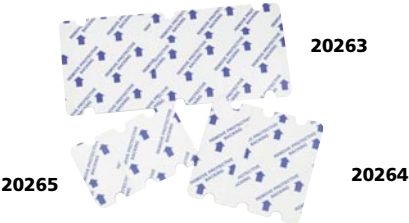
		Maxi Heat Sinks		Mini Heat Sinks		Micro Heat Sinks													
		Threaded	Through Hole	Threaded	Through Hole	Threaded	Through Hole												
<b>Longitudinal Fins</b>		0.4" (10,1 mm) Fin P/N 30482	0.4" (10,1 mm) Fin P/N 30718	0.4" (10,1 mm) Fin P/N 32188	0.4" (10,1 mm) Fin P/N 30195	0.4" (10,1 mm) Fin P/N 32174	0.4" (10,1 mm) Fin P/N 30719												
		0.9" (22,8 mm) Fin P/N 30188	0.9" (22,8 mm) Fin P/N 30181	0.9" (22,8 mm) Fin P/N 30189	0.9" (22,8 mm) Fin P/N 30182	0.9" (22,8 mm) Fin P/N 30190	0.9" (22,8 mm) Fin P/N 30183												
<b>Transverse Fins</b>		0.4" (10,1 mm) Fin P/N 30778	0.4" (10,1 mm) Fin P/N 30720	0.4" (10,1 mm) Fin P/N 30184	0.4" (10,1 mm) Fin P/N 30721	0.4" (10,1 mm) Fin P/N 32173	0.4" (10,1 mm) Fin P/N 30722												
		0.9" (22,8 mm) Fin P/N 30196	0.9" (22,8 mm) Fin P/N 30723	0.9" (22,8 mm) Fin P/N 30269	0.9" (22,8 mm) Fin P/N 30724	0.9" (22,8 mm) Fin P/N 30270	0.9" (22,8 mm) Fin P/N 30725												
<b>Low-profile Side-fin Heat Sinks</b>				<b>Standoffs and Screws</b>															
<p>Height only 0.125" (3,17 mm) above module baseplate*</p>  <p>0.55" (13,97 mm) Side Fins P/N 30096      0.55" (13,97 mm) Side Fins P/N 32190      0.55" (13,97 mm) Side Fins P/N 30095</p> <p><i>Not compatible with standoff kits.</i></p>				<p>Bulk and single-module kits compatible with all standard mounting configurations.</p>  <p>See the following link for complete info: <a href="http://www.vicorpower.com/products/accessories/2nd_gen_standoffs/">www.vicorpower.com/products/accessories/2nd_gen_standoffs/</a></p>															
<b>ThermMate Thermal Pads</b>																			
 <p>20263      20264      20265</p>				<p>For use with Vicor modules, ThermMate thermal pads are a "dry" alternative to thermal compound and are pre-cut to the outline dimensions of the module.</p> <table border="1"> <thead> <tr> <th>THERMAL PAD</th> <th>PART NUMBER</th> <th>THICKNESS</th> </tr> </thead> <tbody> <tr> <td>Maxi (10 pc. pkg.)</td> <td>20263</td> <td>0.007" (0,177 mm)</td> </tr> <tr> <td>Mini (10 pc. pkg.)</td> <td>20264</td> <td>0.007" (0,177 mm)</td> </tr> <tr> <td>Micro (10 pc. pkg.)</td> <td>20265</td> <td>0.007" (0,177 mm)</td> </tr> </tbody> </table>				THERMAL PAD	PART NUMBER	THICKNESS	Maxi (10 pc. pkg.)	20263	0.007" (0,177 mm)	Mini (10 pc. pkg.)	20264	0.007" (0,177 mm)	Micro (10 pc. pkg.)	20265	0.007" (0,177 mm)
THERMAL PAD	PART NUMBER	THICKNESS																	
Maxi (10 pc. pkg.)	20263	0.007" (0,177 mm)																	
Mini (10 pc. pkg.)	20264	0.007" (0,177 mm)																	
Micro (10 pc. pkg.)	20265	0.007" (0,177 mm)																	

\* For thermal curves of low-profile side-fin heat sinks and on-line capability for thermal curve calculations, see the following link:  
[http://www.vicorpower.com/technical\\_library/calculators/calc\\_t-1.xls](http://www.vicorpower.com/technical_library/calculators/calc_t-1.xls)

The Autoranging Rectifier Module (ARM) provides an effective solution for the AC front end of a power supply designed with Vicor DC-DC converters. This high-performance power system building block satisfies a broad spectrum of requirements and agency standards.

The ARM contains all of the power switching and control circuitry necessary for autoranging rectification, inrush current limiting, and overvoltage protection. This module also provides converter enable and status functions for orderly power up / down control or sequencing. To complete the AC front-end configuration, the user needs only to add hold-up capacitors and a suitable input filter with transient protection.

**FUNCTIONAL DESCRIPTION (Figure 7-1)**

**Initial Conditions.** The switch that bypasses the inrush limiting PTC (positive temperature coefficient) thermistor is open when power is applied, as is the switch that engages the strap for voltage doubling. In addition, the downstream DC-DC modules are disabled via the Enable (EN) line, and Bus OK (BOK) is high.

**POWER-UP SEQUENCE (Figure 7-2)**

- 1.1 Upon application of input power, the output bus capacitors begin to charge. The thermistor limits the charge current, and the exponential time constant is determined by the hold-up capacitor value and the thermistor cold resistance. The slope (dv/dt) of the capacitor voltage approaches zero as the capacitors become charged to the peak of the AC line voltage.
- 2.1 If the bus voltage is less than 200 V as the slope nears zero, the voltage doubler is activated, and the bus voltage climbs exponentially to twice the peak line voltage. If the bus voltage is greater than 200 V, the doubler is not activated.
- 3.1 If the bus voltage is greater than 235 V as the slope approaches zero, the inrush limiting thermistor is bypassed. Below 235 V, the thermistor is not bypassed.
- 4.1 The converters are enabled ~150 milliseconds after the thermistor bypass switch is closed.
- 5.1 Bus OK is asserted after an additional ~150 millisecond delay to allow the converter outputs to settle within specification.

**POWER-DOWN SEQUENCE (Figure 7-2)**

When input power is turned off or fails, the following sequence occurs as the bus voltage decays:

- 1.2 Bus OK is de-asserted when the bus voltage falls below 205 Vdc (typical).
- 2.2 The converters are disabled when the bus voltage falls below 200 Vdc. If power is reapplied after the converters are disabled, the entire power-up sequence is repeated. If a momentary power interruption occurs and power is re-established before the bus reaches the disable threshold, the power-up sequence is not repeated.

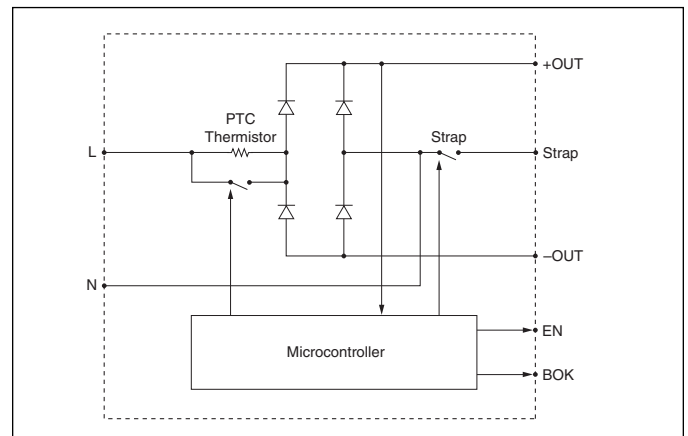

Figure 7-1 — Functional block diagram

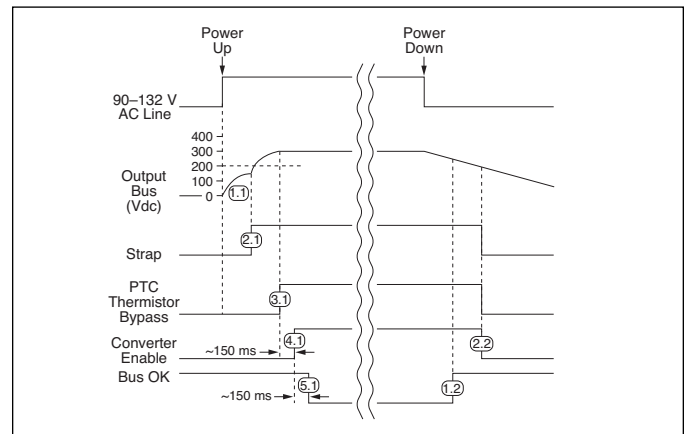

Figure 7-2 — Timing diagram: power up / down sequence

## OFF-LINE POWER SUPPLY CONFIGURATION

The ARM maintains the DC output bus voltage between 200 and 375 Vdc over the entire universal input range, this being compatible with the Maxi, Mini, Micro 300 V input converters as well as VI-260 family and VI-J60 family DC-DC converters. The ARM automatically switches to the proper rectification mode (doubled or undoubled) depending on the input voltage, eliminating the possibility of damage due to improper line connection. The VI-ARM-x1 is rated at 500 W in the low range (90 – 132 Vac input), and 750 W in the high range (180 – 264 Vac input). The VI-ARMB-x2 is rated for 750 W and 1,500 W for the low and high input ranges respectively. Either of these modules can serve as the AC front end for any number and combination of compatible converters as long as the maximum power rating is not exceeded. See VI-ARMB derating curves (Figures 1 and 2) on [VI-ARM data sheet](#).

**Strap (ST) Pin.** In addition to input and output power pin connections, it is necessary to connect the Strap pin to the junction of the series hold-up capacitors (C1, C2, Figure 7-3) for proper (autoranging) operation. Varistors across the capacitors provide input transient protection. The bleeder resistors (R1, R2, Figure 7-3) discharge the hold-up capacitors when power is switched off.

**Enable (EN) Pin.** (Figure 7-4) The Enable pin must be connected to the PC or GATE IN pin of all converter modules to disable the converters during power up. Otherwise, the converters would attempt to start while the hold-up

capacitors were being charged through an un-bypassed thermistor, preventing the bus voltage from reaching the thermistor bypass threshold, thus disabling the power supply. The Enable output (the drain of a N channel MOSFET) is internally pulled up to 15 V through a 150 kΩ resistor.

A signal diode should be placed close to and in series with the PC or GATE IN pin of each converter to eliminate the possibility of control interference between converters. The Enable pin switches to the high state (15 V) with respect to the negative output power pin to turn on the converters after the power-up inrush is over. The Enable function also provides input overvoltage protection for the converters by turning off the converters if the DC bus voltage exceeds 400 Vdc. The thermistor bypass switch opens if this condition occurs, placing the thermistor in series with the input voltage, which reduces the bus voltage to a safe level while limiting input current in case the varistors conduct. The thermistor bypass switch also opens if a fault or overload reduces the bus voltage to less than 180 Vdc.

**CAUTION:** There is no input to output isolation in the ARM, hence the –Out of the ARM and thus the –In of the downstream DC-DC converter(s) are at a high potential. If it is necessary to provide an external enable / disable function by controlling the DC-DC converter’s PC or GATE IN pin (referenced to the –In) of the converter an opto-isolator or isolated relay should be employed.

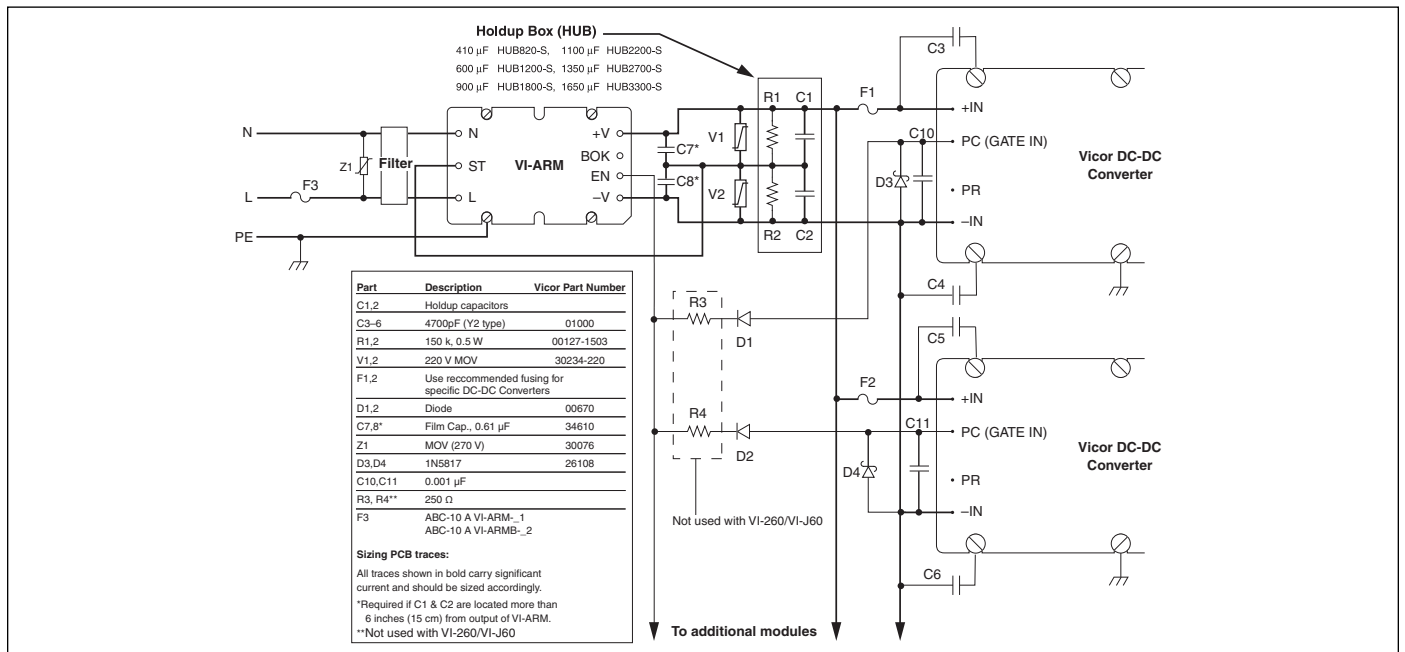

Figure 7-3 — Typical ARM application

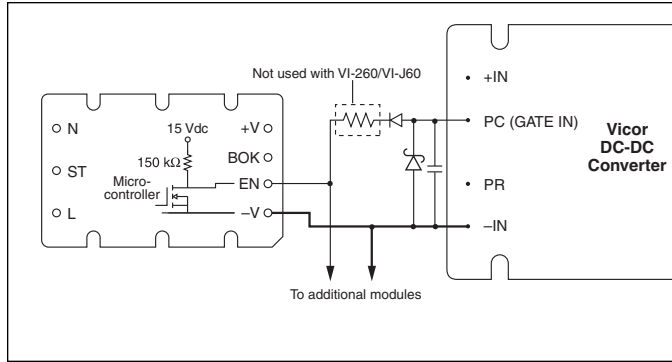

Figure 7-4 — Enable (EN) function

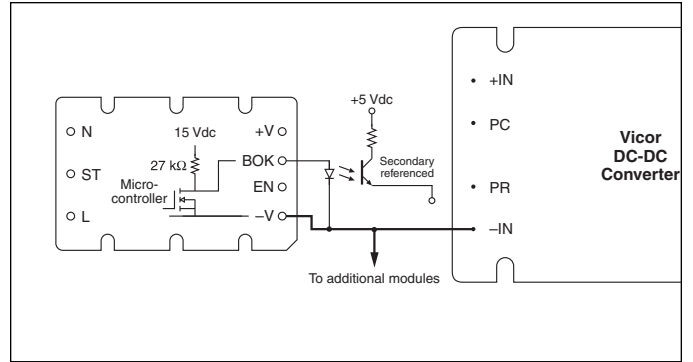

Figure 7-5 — Bus OK (BOK) isolated power status indicator

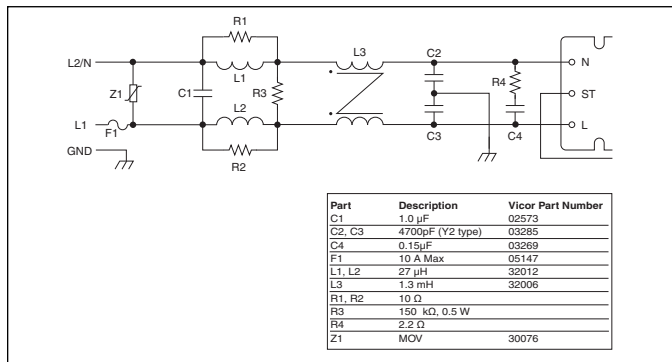

Figure 7-6a — Recommended filter design; Low power filter connection for VI-ARM-x1

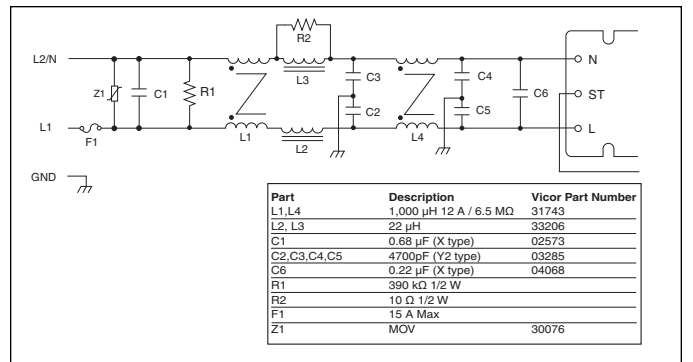

Figure 7-6b — Recommended filter design; High power filter connection for VI-ARMB-x2

**Bus OK (BOK) Pin.** (Figure 7-5) The Bus OK pin is intended to provide early-warning power fail information and is also referenced to the negative output pin.

**CAUTION:** There is no input-to-output isolation in the ARM. It is necessary to monitor Bus OK via an optocoupler if it is to be used on the secondary (output) side of the converters. A line-isolation transformer should be used when performing scope measurements. Scope probes should never be applied simultaneously to the input and output as this will damage the module.

**Filter.** Two input filter recommendations are shown for low-power VI-ARM-x1 and high-power VI-ARMB-x2. (Figures 7-6a and 7-6b)

Both filter configurations provide sufficient common-mode and differential-mode insertion loss in the frequency range between 100 kHz and 30 MHz to comply with the Class B conducted emissions limit.

**Hold-up Capacitors.** Hold-up capacitor values should be determined according to output bus voltage ripple, power fail hold-up time, and ride-through time. (Figure 7-7) Many applications require the power supply to maintain output regulation during a momentary power failure of

specified duration, i.e., the converters must hold up or ride through such an event while maintaining undisturbed output voltage regulation. Similarly, many of these same systems require notification of an impending power failure to allow time to perform an orderly shutdown.

The energy stored on a capacitor, which has been charged to voltage V, is:

$$\mathcal{E} = 1/2(CV^2) \quad (1)$$

where:  $\mathcal{E}$  = stored energy

C = capacitance

V = voltage across the capacitor

Energy is given up by the capacitors as they are discharged by the converters. The energy expended (the power-time product) is:

$$\mathcal{E} = P\Delta t = C(V_1^2 - V_2^2) / 2 \quad (2)$$

where: P = operating power

$\Delta t$  = discharge interval

V<sub>1</sub> = capacitor voltage at the beginning of  $\Delta t$

V<sub>2</sub> = capacitor voltage at the end of  $\Delta t$

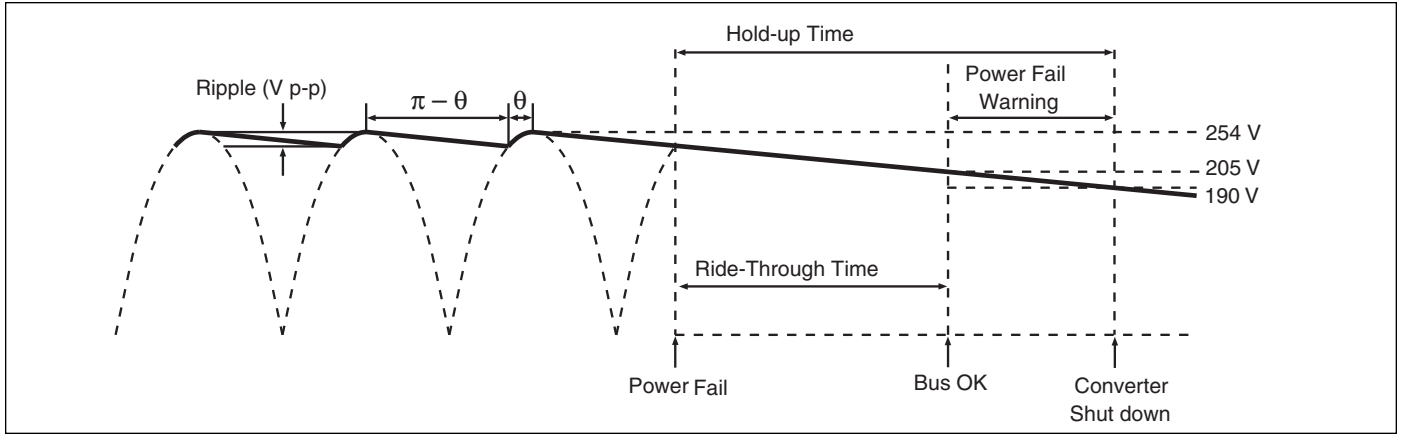

Figure 7-7 — General timing diagram of bus voltage following interruption of the AC mains

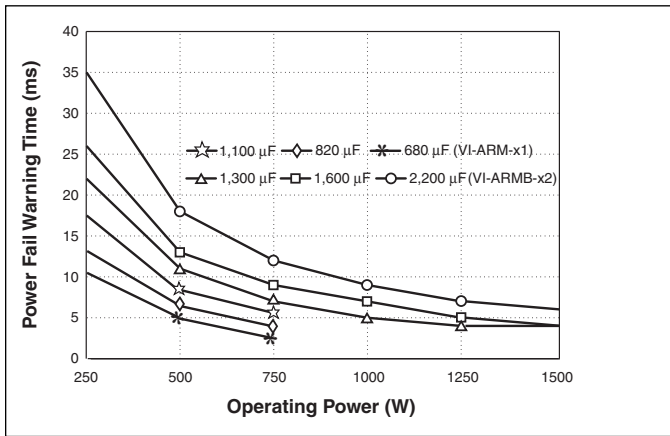

Figure 7-8 — Power fail warning time vs. operating power and total bus capacitance, series combination of C1, C2 (Figure 7-3)

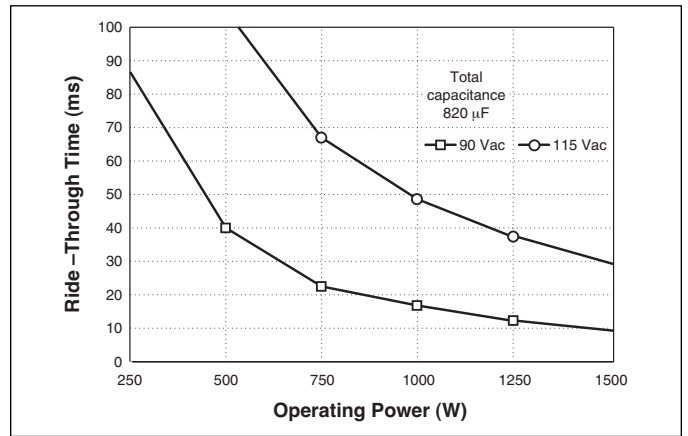

Figure 7-9 — Ride-through time vs. operating power

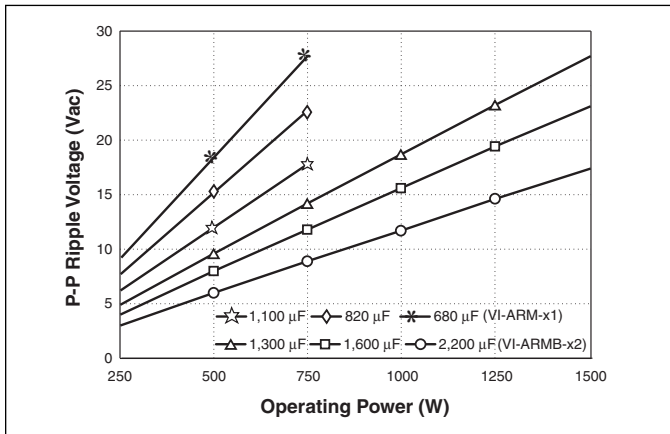

Figure 7-10 — Ripple voltage vs. operating power and bus capacitance, series combination of C1, C2 (Figure 7-3)

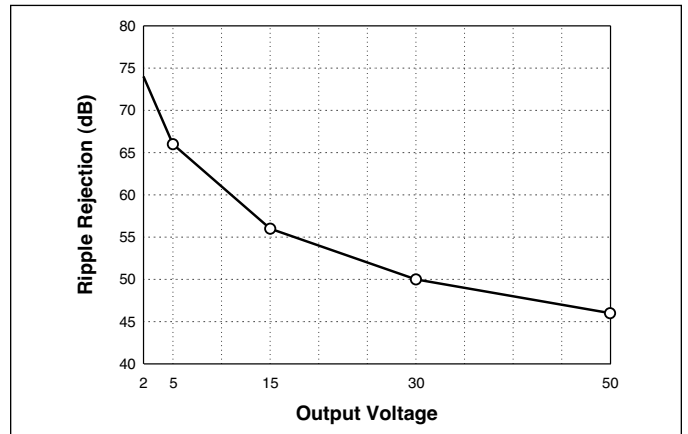

Figure 7-11 — Converter ripple rejection vs. output voltage (Typical)

Rearranging equation 2 to solve for the required capacitance:

$$C = 2P\Delta t / (V_1^2 - V_2^2) \quad (3)$$

The power fail warning time ( $\Delta t$ ) is defined as the interval between (BOK) and converter shutdown (EN) as illustrated in Figure 7-7. The Bus OK and Enable thresholds are 205 V and 190 V, respectively. A simplified relationship between power fail warning time, operating power, and bus capacitance is obtained by inserting these constants:

$$C = 2P\Delta t / (205^2 - 190^2)$$

$$C = 2P\Delta t / (5,925)$$

It should be noted that the series combination ( $C_1$ ,  $C_2$ , Figure 7-3) requires each capacitor to be twice the calculated value, but the required voltage rating is reduced to 200 V.

Allowable ripple voltage on the bus (or ripple current in the capacitors) may define the capacitance requirement. Consideration should also be given to converter ripple rejection and resulting output ripple voltage.

For example, a converter whose output is 15 V and nominal input is 300 V will provide typically 56 dB ripple rejection, i.e., 10 V p-p of input ripple will produce 15 mV p-p of output ripple. (Figure 7-11) Equation 3 is again used to determine the required capacitance. In this case,  $V_1$  and  $V_2$  are the instantaneous values of bus voltage at the peaks and valleys (Figure 7-7) of the ripple, respectively. The capacitors must hold up the bus voltage for the time interval ( $\Delta t$ ) between peaks of the rectified line as given by:

$$\Delta t = (\pi - \theta) / 2\pi f \quad (4)$$

where:  $f$  = line frequency

$\theta$  = rectifier conduction angle

(Figure 7-7)

The approximate conduction angle is given by:

$$\theta = \cos^{-1} V_2 / V_1 \quad (5)$$

Another consideration in hold-up capacitor selection is their ripple current rating. The capacitors' rating must be higher than the maximum operating ripple current.

The approximate operating ripple current (rms) is given by:

$$I_{rms} = 2P / V_{ac} \quad (6)$$

where:  $P$  = operating power level

$V_{ac}$  = operating line voltage

Calculated values of bus capacitance for various hold-up time, ride-through time, and ripple voltage requirements are given as a function of operating power level in Figures 7-8, 7-9, and 7-10, respectively.

### EXAMPLE

In this example, the output required at the point of load is 12 Vdc at 320 W. Therefore, the output power from the ARM would be 375 W (assuming a converter efficiency of 85%). The desired hold-up time is at least 9 ms over an input range of 90 to 264 Vac.

**Determining Required Capacitance for Power Fail Warning.** Figure 7-8 is used to determine capacitance for a given power fail warning time and power level, and shows that the total bus capacitance must be at least 820  $\mu$ F. Since two capacitors are configured in series, each capacitor must be at least 1,640  $\mu$ F.

**NOTE:** The warning time is not dependent on line voltage. A hold-up capacitor calculator is available on the Vicor website, at [vicorpower.com/hubcalc](http://vicorpower.com/hubcalc).

**Determining Ride-through Time.** Figure 7-9 illustrates ride-through time as a function of line voltage and output power, and shows that at a nominal line of 115 Vac, ride-through would be 68 ms. Ride-through time is a function of line voltage.

**Determining Ripple Voltage on the Hold-up Capacitors.** Figure 7-10 is used to determine ripple voltage as a function of operating power and bus capacitance, and shows that the ripple voltage across the hold-up capacitors will be 12 Vac.

**Determining the Ripple on the Output of the DC-DC Converter.** Figure 7-11 is used to determine the ripple rejection of the DC-DC converter and indicates a ripple rejection of approximately 60 dB for a 12 V output. If the ripple on the bus voltage is 12 Vac and the ripple rejection of the converter is 60 dB, the output ripple of the converter due to ripple on its input (primarily 120 Hz) will be 12 mV p-p.

The Filter / Autoranging Rectifier Module (FARM) provides an effective solution for the AC front end of a power supply built with Vicor DC-DC converters. This high-performance power-system building block satisfies a broad spectrum of requirements and agency standards.

In addition to providing transient / surge immunity and EMI filtering, the FARM contains all of the power switching and control circuitry necessary for autoranging rectification, inrush current limiting, and overvoltage protection. This module also provides converter enable and status functions for orderly power up / down control or sequencing. To complete the AC front-end configuration, the user only needs to add hold-up capacitors, and a few discrete components.

### FUNCTIONAL DESCRIPTION (Figure 8-1)

**Initial Condition.** The switch that bypasses the inrush limiting PTC (positive temperature coefficient) thermistor is open when power is applied, as is the switch that engages the strap for voltage doubling. In addition, the converters are disabled via the Enable (EN) line, and Bus OK (BOK) is high.

### POWER-UP SEQUENCE (Figure 8-2)

- 1.1 Upon application of input power, the output bus capacitors begin to charge. The thermistor limits the charge current, and the exponential time constant is determined by the hold-up capacitor value and the thermistor cold resistance. The slope (dv/dt) of the capacitor voltage versus time approaches zero as the capacitors become charged to the peak of the AC line voltage. If the bus voltage is less than 200 V as the slope nears zero, the voltage doubler is activated, and the bus voltage climbs exponentially to twice the peak line voltage.
- 2.1 If the bus voltage is greater than 200 V, the doubler is not activated.
- 3.1 If the bus voltage is greater than 235 V as the slope approaches zero, the inrush limiting thermistor is bypassed. Below 235 V, it is not bypassed.
- 4.1 The converters are enabled ~150 ms after the thermistor bypass switch is closed.
- 5.1 Bus OK is asserted after an additional ~150 ms delay to allow the converter outputs to settle within specification.

### POWER-DOWN SEQUENCE (Figure 8-2)

When input power is turned off or fails, the following sequence occurs as the bus voltage decays:

- 1.2 Bus OK is de-asserted when the bus voltage falls below 205 Vdc (Typical).
- 2.2 The converters are disabled when the bus voltage falls below 190 Vdc. If power is reapplied after the converters are disabled, the entire power-up sequence is repeated. If a momentary power interruption occurs and power is re-established before the bus reaches the disable threshold, the power-up sequence is not repeated, i.e., the power supply “rides through” the momentary interruption.

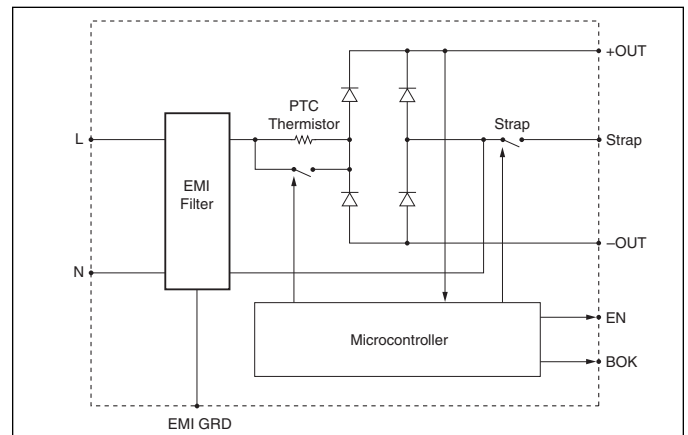

Figure 8-1 — Functional block diagram: FARM

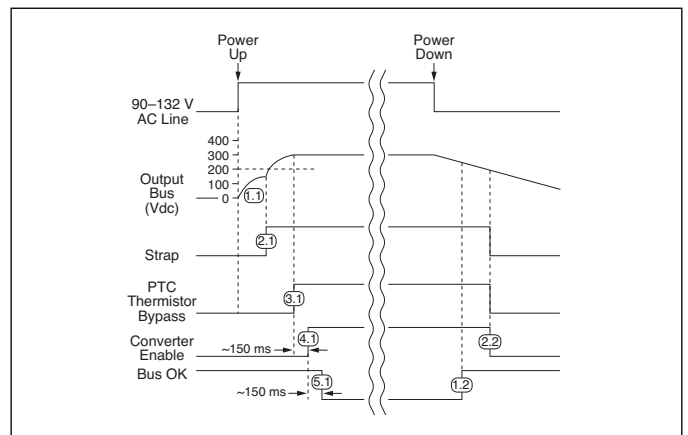

Figure 8-2 — Timing diagram: power up/down sequence

**OFF-LINE POWER SUPPLY CONFIGURATION**

The FARM maintains the DC output bus voltage between 250 and 370 Vdc over the entire input-voltage range, which is compatible with the Maxi, Mini, Micro 300 V input converters as well as VI-260 family and VI-J60 family DC-DC converters. The FARM automatically switches to the proper bridge or doubler mode depending on the input voltage, eliminating the possibility of damage due to improper line connection. The FARM1xxx is rated at 500 W in the low range (90 – 132 Vac input), and 750 W in the high range (180 – 264 Vac input). The FARM2xxx is rated for 750 W and 1,000 W for the low and high input ranges respectively. Either of these modules can serve as the AC front end for any number and combination of compatible converters as long as the maximum power rating is not exceeded.

**Strap (ST) Pin.** In addition to input and output power pin connections, it is necessary to connect the Strap pin to the center junction of the series hold-up capacitors (C1, C2, Figure 8–3) for proper (autoranging) operation. Metal-oxide varistors, V1 and V2 provide capacitor protection. The bleeder resistors (R1, R2, Figure 8–3) discharge the hold-up capacitors when power is switched off. Capacitors C7 and C8 are recommended if the hold-up capacitors are located more than 3 inches (75 mm) from the FARM output pins.

**Enable (EN) Pin.** (Figure 8-4) The Enable pin must be connected to the PC or GATE IN pin of all converter modules to disable the converters during power up. Otherwise, the converters would attempt to start while

the hold-up capacitors were being charged through an un-bypassed current-limiting thermistor, preventing the bus voltage from reaching the thermistor bypass threshold, thus disabling the power supply. The Enable output (the drain of an N channel MOSFET) is internally pulled up to 15 V through a 150 kΩ resistor.

A signal diode should be placed close to and in series with the PC or GATE IN pin of each converter to eliminate the possibility of control interference between converters. The Enable pin switches to the high state (15 V) with respect to the negative output power pin to turn on the converters after the power-up inrush is over. The Enable function also provides input overvoltage protection for the converters by turning off the converters if the DC bus voltage exceeds 400 Vdc. The thermistor bypass switch opens if this condition occurs, placing the thermistor in series with the input voltage, which reduces the bus voltage to a safe level while limiting input current in case the varistors conduct. The thermistor bypass switch also opens if a fault or overload reduces the bus voltage to less than 180 Vdc.

**CAUTION:** There is no input to output isolation in the FARM, hence the –Out of the FARM and thus the –In of the downstream DC-DC converter(s) are at a high potential. If it is necessary to provide an external enable / disable function by controlling the DC-DC converter’s PC or GATE IN pin (referenced to the –In) of the converter an opto-isolator or isolated relay should be employed.

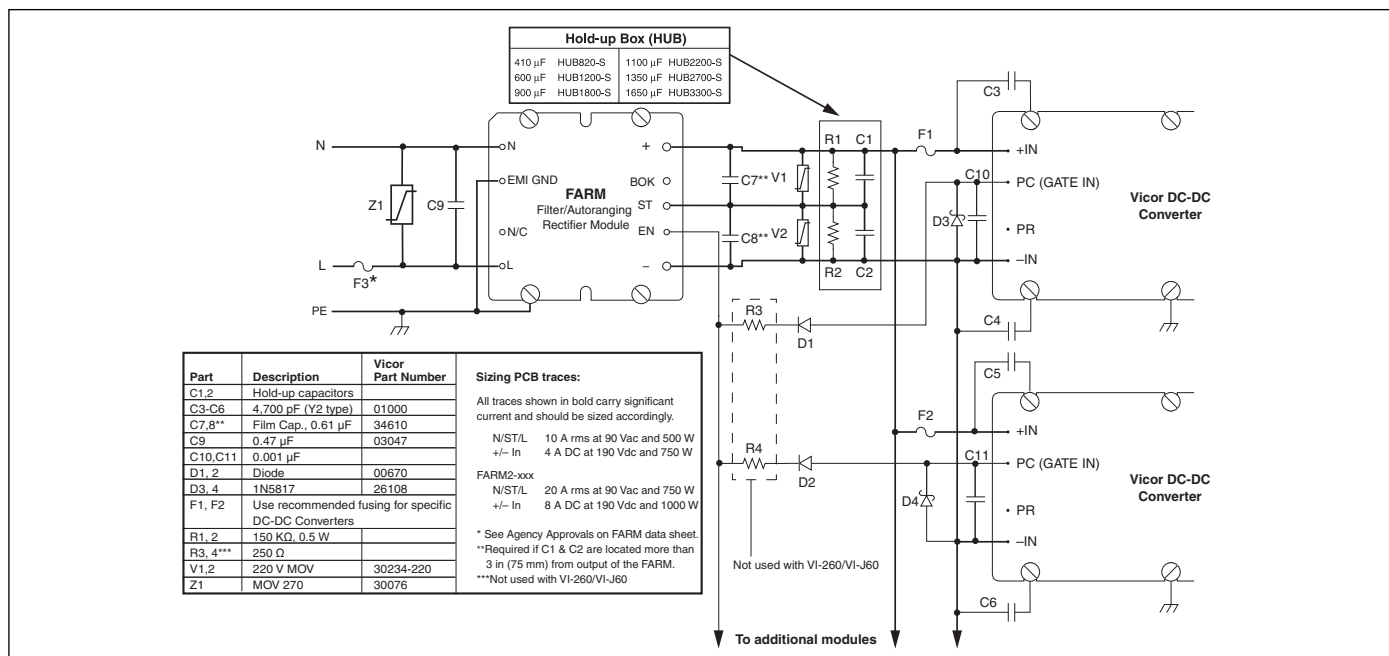

Figure 8–3 — Offline power supply configuration

**Bus OK (BOK) Pin.** (Figure 8–5) The Bus OK pin is intended to provide early-warning power-fail information and is also referenced to the negative output pin.

**CAUTION:** There is no input-to-output isolation in the FARM. It is necessary to monitor Bus OK via an optoisolator if it is to be used on the secondary (output) side of the converters. A line-isolation transformer should be used when performing scope measurements. Scope probes should never be applied simultaneously to the input and output as this will damage the module.

**Filter.** (Figure 8–6) An integral input filter consists of a common-mode choke and Y-capacitors (line-ground) plus two X-capacitors (line-line). This filter configuration provides common-mode and differential-mode insertion loss in the frequency range between 100 kHz and 30 MHz.

**Hold-up Capacitors.** Hold-up capacitor values should be determined according to output bus voltage ripple, power fail hold-up time, and ride-through time. (Figure 8–7)

Many applications require the power supply to maintain output regulation during a momentary power failure of specified duration, i.e., the converters must hold up or ride through such an event while maintaining undisturbed output voltage regulation. Similarly, many of these same systems require notification of an impending power failure to allow time to perform an orderly shut down.

The energy stored in a capacitor which has been charged to voltage V is:

$$\mathcal{E} = 1/2(CV^2) \quad (1)$$

where:  $\mathcal{E}$  = stored energy

C = capacitance

V = voltage across the capacitor

Energy is given up by the capacitors as they are discharged by the converters. The energy expended (the power-time product) is:

$$\mathcal{E} = P\Delta t = C(V_1^2 - V_2^2) / 2 \quad (2)$$

where: P = operating power

$\Delta t$  = discharge interval

V1 = capacitor voltage at the beginning of  $\Delta t$

V2 = capacitor voltage at the end of  $\Delta t$

Rearranging Equation 2 to solve for the required capacitance:

$$C = 2P\Delta t / (V_1^2 - V_2^2) \quad (3)$$

The power fail warning time ( $\Delta t$ ) is defined as the interval between Bus OK and converter shut down (EN) as illustrated in Figure 8–7. The Bus OK and Enable thresholds are 205 V and 190 V, respectively. A simplified relationship between power fail warning time, operating power, and bus capacitance is obtained by inserting these constants:

$$C = 2P\Delta t / (205^2 - 190^2)$$

$$C = 2P\Delta t / (5,925)$$

It should be noted that the series combination (C1, C2, Figure 8–3) requires each capacitor to be twice the calculated value, but the required voltage rating of each capacitor is reduced to 200 V. Allowable ripple voltage on the bus (or ripple current in the capacitors) may define the capacitance requirement. Consideration should be given to converter ripple rejection and resulting output ripple voltage.

For example, a converter whose output is 15 V and nominal input is 300 V will provide 56 dB ripple rejection, i.e., 10 V p-p of input ripple will produce 15 mV p-p of output ripple. (Figure 8–11) Equation 3 is again used to determine the required capacitance. In this case, V1 and V2 are the instantaneous values of bus voltage at the peaks and valleys (Figure 8–7) of the ripple, respectively. The capacitors must hold up the bus voltage for the time interval ( $\Delta t$ ) between peaks of the rectified line as given by:

$$\Delta t = (\pi - \theta) / 2\pi f \quad (4)$$

where: f = line frequency

$\theta$  = rectifier conduction angle

(Figure 8–7)

The approximate conduction angle is given by:

$$\theta = \cos^{-1}(V_2 / V_1) \quad (5)$$

Another consideration in hold-up capacitor selection is their ripple current rating. The capacitors' rating must be higher than the maximum operating ripple current. The approximate operating ripple current (rms) is given by:

$$I_{rms} = 2P / V_{ac} \quad (6)$$

where: P = total output power

V<sub>ac</sub> = operating line voltage

Calculated values of bus capacitance for various hold-up time, ride-through time, and ripple-voltage requirements are given as a function of operating power level in Figures 8–8, 8–9, and 8–10, respectively.

**EXAMPLE**

In this example, the output required from the DC-DC converter at the point of load is 12 Vdc at 320 W. Therefore, the output power from the FARM would be 375 W (assuming a converter efficiency of 85%). The desired hold-up time is 9 ms over an input range of 90 to 264 Vac.

**Determining Required Capacitance for Power Fail Warning.** Figure 8–8 is used to determine capacitance for a given power fail warning time and power level, and shows that the total bus capacitance must be at least 820  $\mu$ F. Since two capacitors are configured in series, each capacitor must be at least 1,640  $\mu$ F.

**NOTE:** The warning time is not dependent on line voltage. A hold-up capacitor calculator is available on the Vicor website, at [vicorpower.com/hubcalc](http://vicorpower.com/hubcalc).

**Determining Ride-through Time.** Figure 8–9 illustrates ride-through time as a function of line voltage and output power, and shows that at a nominal line of 90 Vac, ride-through would be 68 ms. Ride-through time is a function of line voltage.

**Determining Ripple Voltage on the Hold-up Capacitors.** Figure 8–10 is used to determine ripple voltage as a function of operating power and bus capacitance, and shows that the ripple voltage across the hold-up capacitors will be 12 V p-p.

**Determining the Ripple on the Output of the DC-DC Converter.** Figure 8–11 is used to determine the ripple rejection of the DC-DC converter and indicates a ripple rejection of approximately 60 dB for a 12 V output. Since the ripple on the bus voltage is 12 Vac and the ripple rejection of the converter is 60 dB, the output ripple of the converter due to ripple on its input (primarily 120 Hz) will be 12 mV p-p.

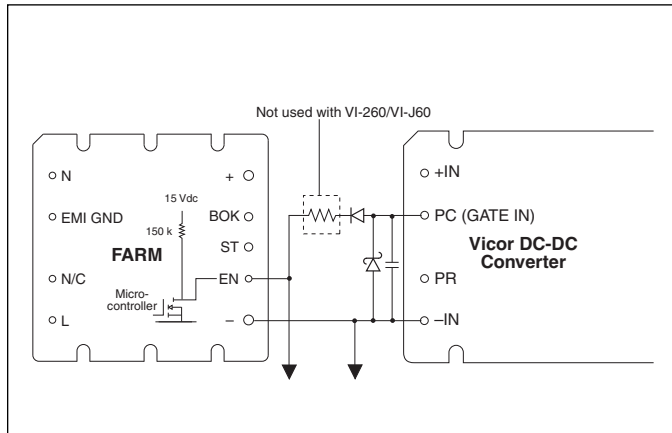

Figure 8–4 — Enable (EN) function

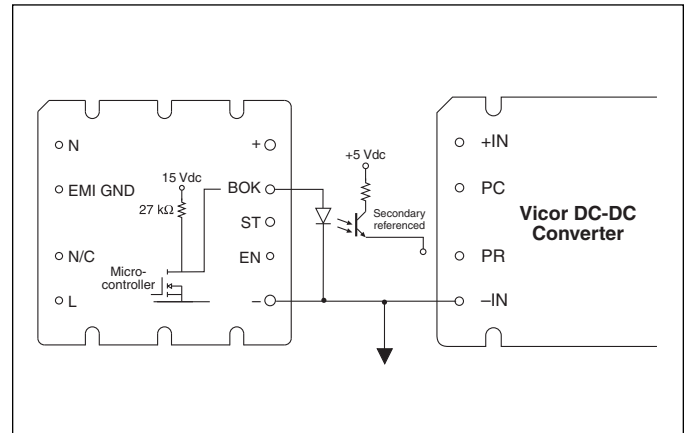

Figure 8–5 — Bus OK (BOK) isolated power status indicator

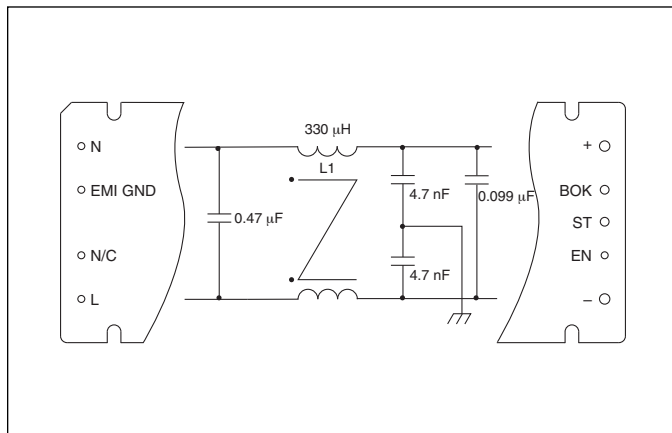

Figure 8–6 — Internal filter

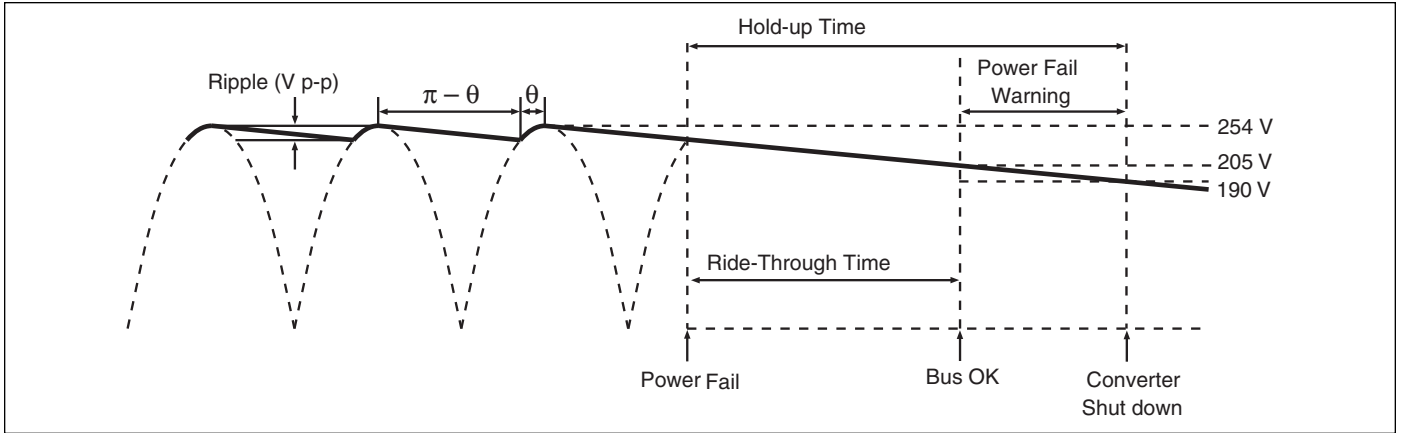

Figure 8-7 — General timing diagram of bus voltage following interruption of the AC mains

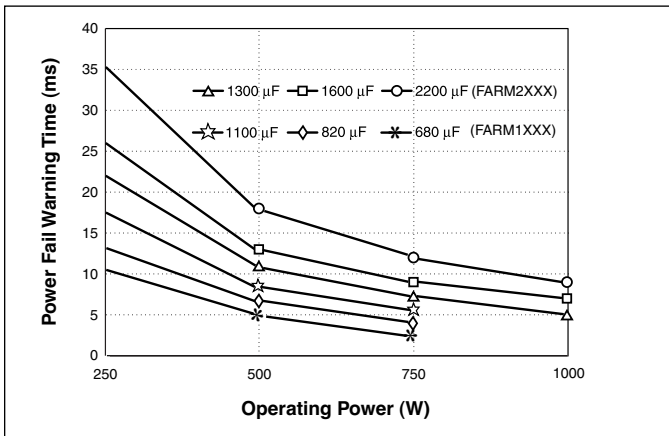

Figure 8-8 — Power fail warning time vs. operating power and total bus capacitance, series combination of C1, C2 (Figure 8-3)

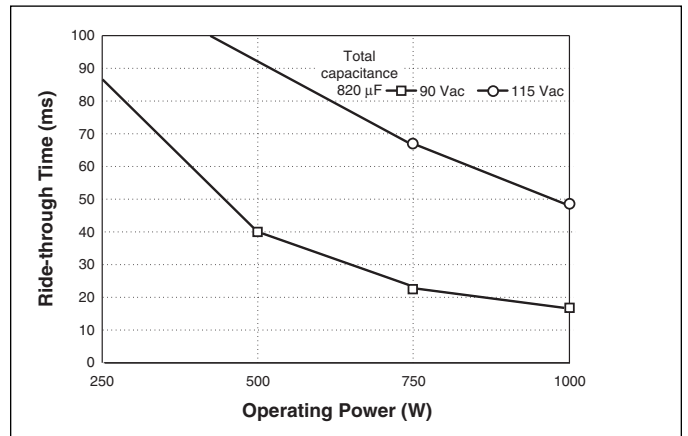

Figure 8-9 — Ride-through time vs. operating power

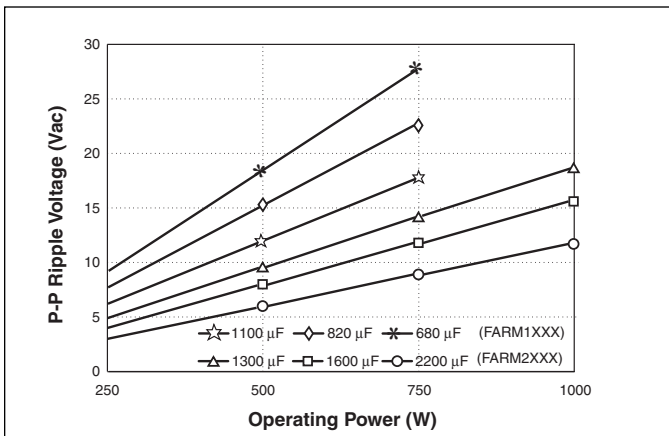

Figure 8-10 — Ripple voltage vs. operating power and bus capacitance, series combination of C1, C2 (Figure 8-3)

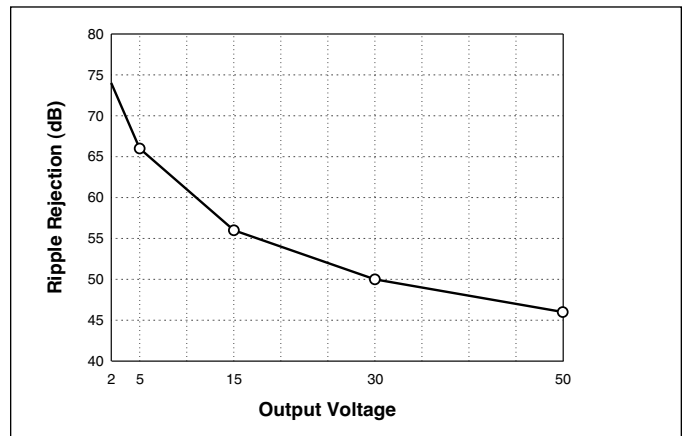

Figure 8-11 — Converter ripple rejection vs. output voltage (Typical)

The ENMod component power front-end system for EN compliance provides an effective solution for an AC front end of a power supply enabled with Vicor DC-DC converters. The ENMod system's basic building blocks are the MiniHAM passive harmonic attenuation module, the FARM3 autoranging AC-DC front-end module (Figure 9–3) and a discrete EMI filter.

filtering, in addition to all of the power switching and control circuitry necessary for autoranging rectification, inrush current limiting, and overvoltage protection. Converter enable and status functions for orderly power up / down control or sequencing are also provided. To complete the AC front-end configuration, the user only needs to add hold-up capacitors, EMI filter (Figure 9–1b), and a few discrete components.

The ENMod system provides transient / surge immunity, harmonic current attenuation (Figure 9–2) and EMI

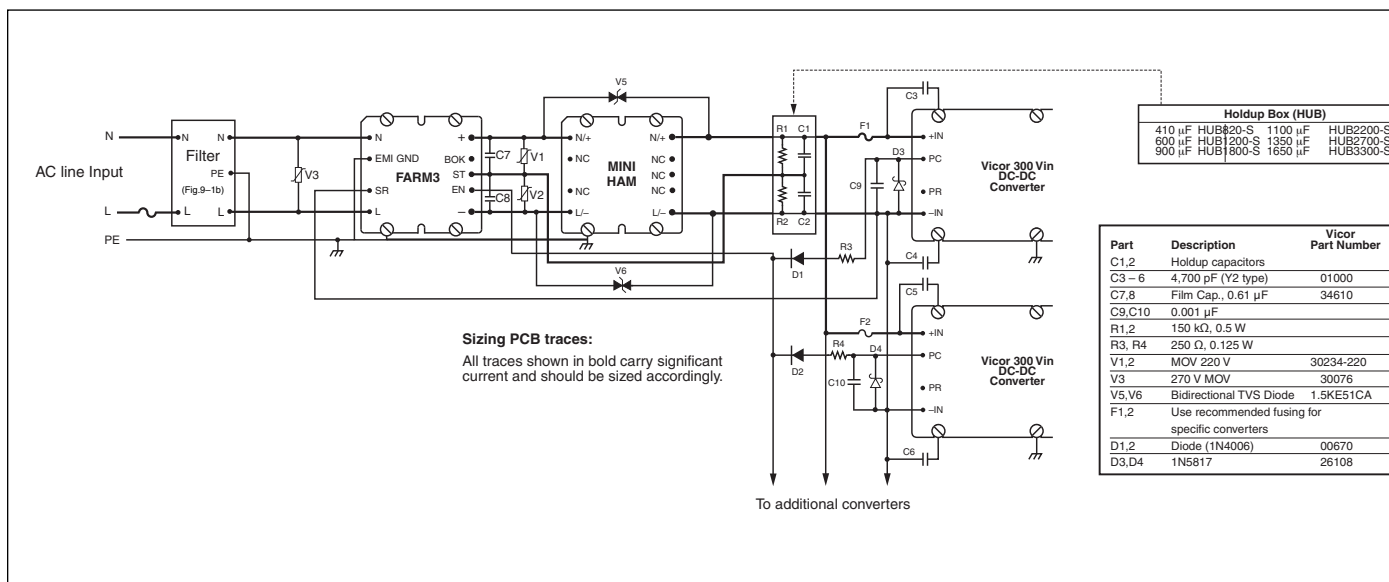

Figure 9-1a — Offline power supply configuration

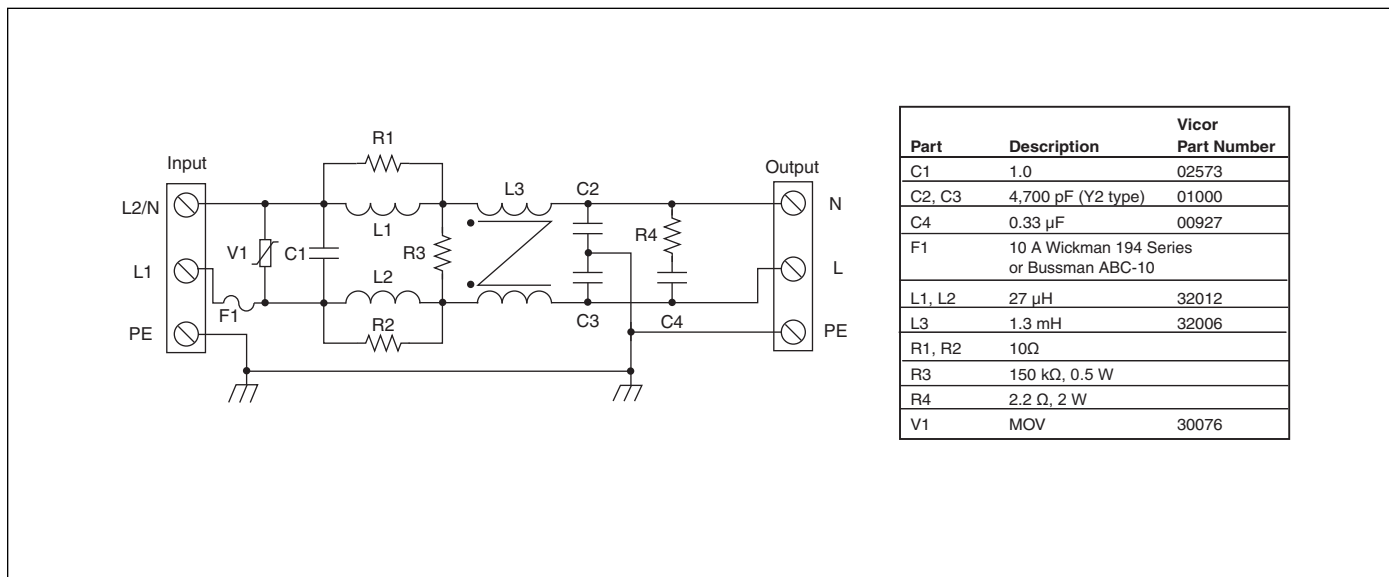

Figure 9-1b — Input EMI filter for EN55022, Class B compliance

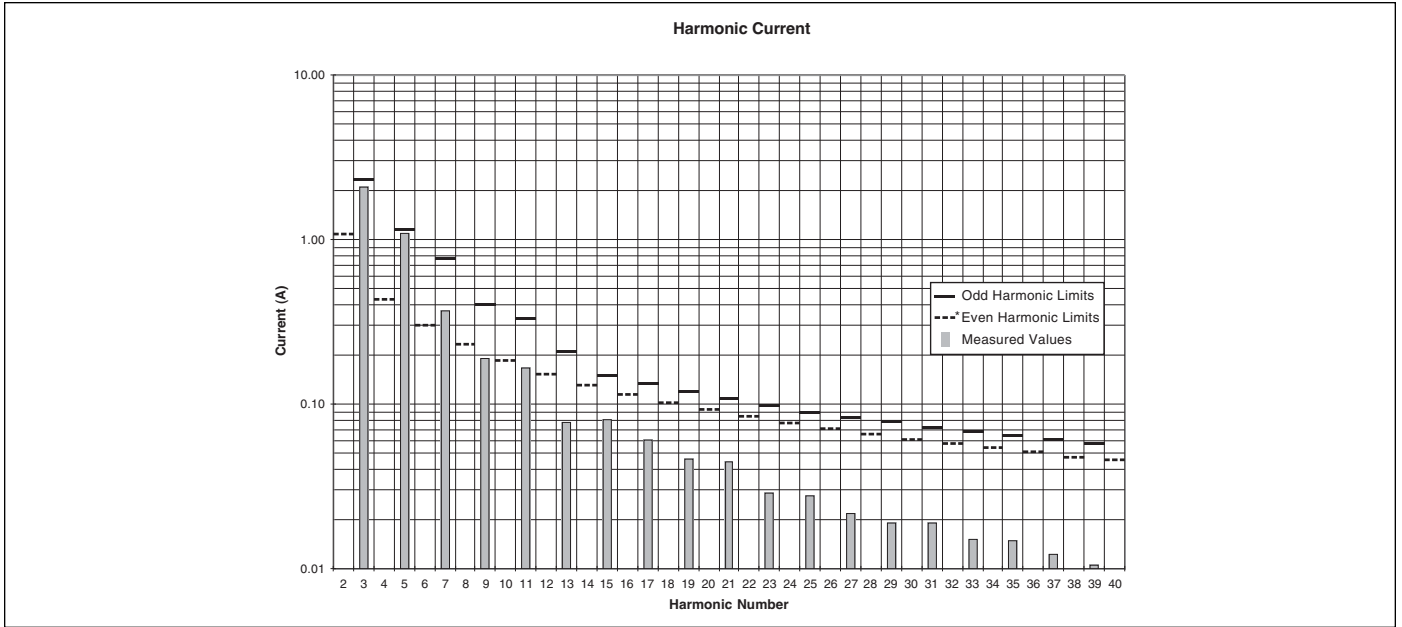

Figure 9-2 — Measured harmonic current at 230 Vac, 575 W vs. EN spec limits (\*Measured values of even harmonics are below 0.01 A)

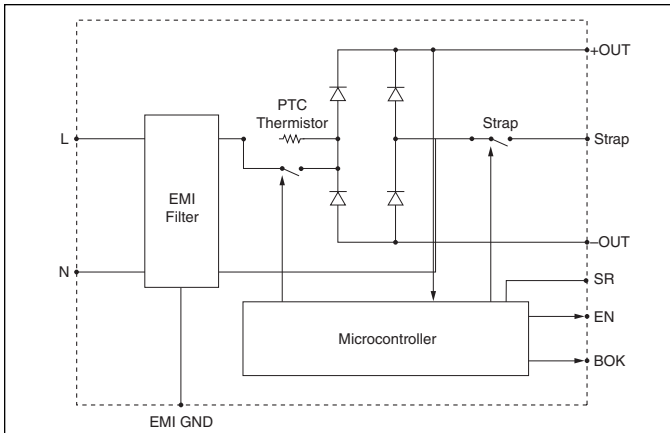

Figure 9-3 — Functional block diagram: FARM3 module

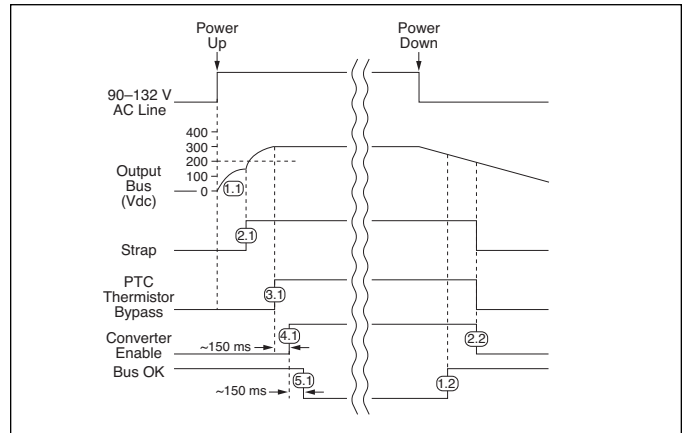

Figure 9-4 — Timing diagram: Power-up / down sequence

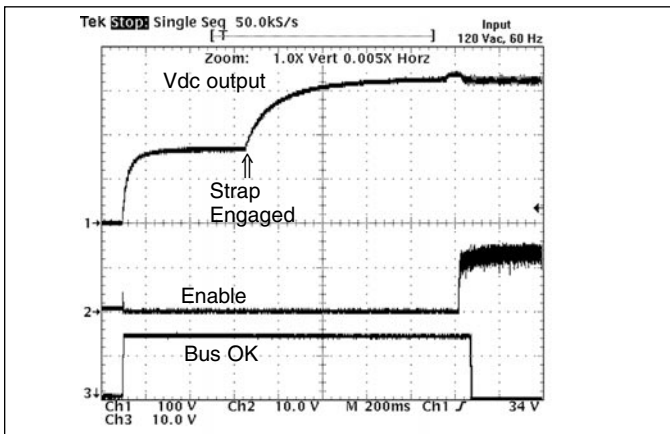

Figure 9-5 — Start up at 120 Vac input

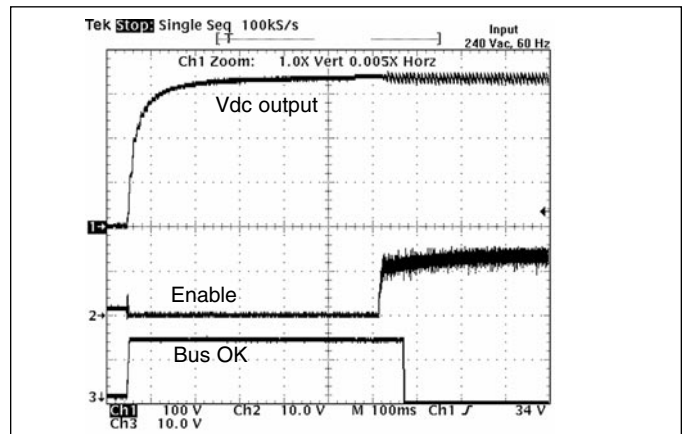

Figure 9-6 — Start up at 240 Vac input

**POWER-UP SEQUENCE (Figure 9-4)**

1.1 Upon application of input power, the hold-up capacitors begin to charge. The thermistor limits the charge current, and the exponential time constant is determined by the hold-up capacitor value and the thermistor cold resistance. The slope ( $dV/dt$ ) of the capacitor voltage versus time approaches zero as the capacitors become charged to the peak of the AC line voltage.

The switch that bypasses the inrush limiting PTC (positive-temperature coefficient) thermistor is open when power is applied, as is the switch that engages the strap for voltage doubling. In addition, the converter modules are disabled via the Enable (EN) line, and Bus OK (BOK) is high.

- 2.1 If the bus voltage is less than 200 V as the slope nears zero, the voltage doubler is activated, and the bus voltage climbs exponentially to twice the peak line voltage. If the bus voltage is greater than 200 V, the doubler is not activated.
- 3.1 If the bus voltage is greater than 235 V as the slope approaches zero, the inrush limiting thermistor is bypassed. Below 235 V, it is not bypassed.
- 4.1 The converters are enabled  $\sim 150$  ms after the thermistor bypass switch is closed.
- 5.1 Bus OK is asserted after an additional  $\sim 150$  ms delay to allow the converter outputs to settle within specification.

**POWER-DOWN SEQUENCE (Figure 9-4)**

When input power is turned off or fails, the following sequence occurs as the bus voltage decays:

- 1.2 Bus OK is de-asserted when the bus voltage falls below 210 Vdc.
- 2.2 The converters are disabled when the bus voltage falls below 190 Vdc. If power is reapplied after the converters are disabled, the entire power-up sequence is repeated. If a momentary power interruption occurs and power is reestablished before the bus reaches the disable threshold, the power-up sequence is not repeated, i.e., the power conversion system "rides through" the momentary interruption.

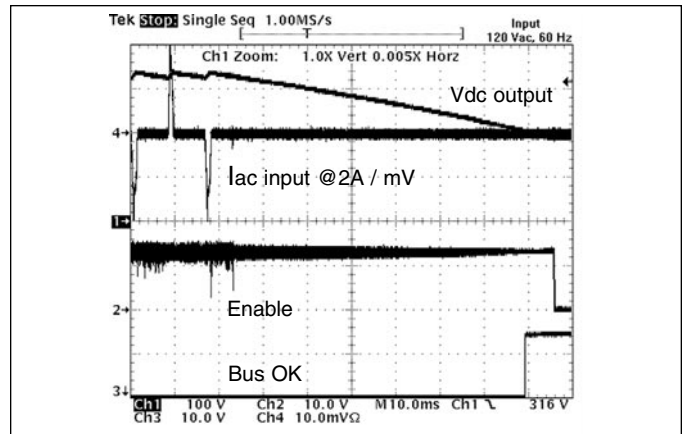

Figure 9-7 — Power down from 120 Vac

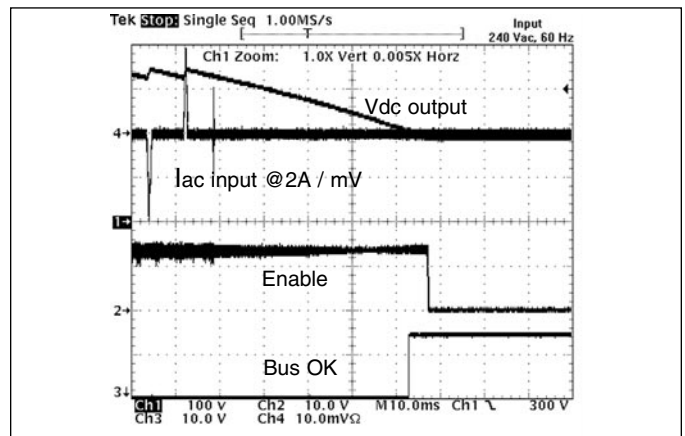

Figure 9-8 — Power down from 240 Vac

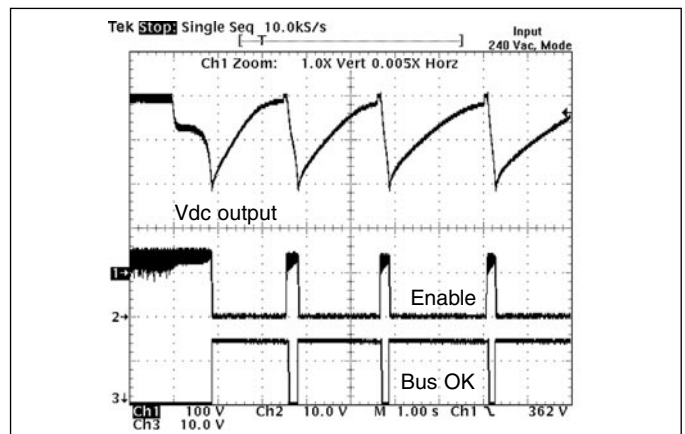

Figure 9-9 — Output overvoltage protection 240 Vac range

**FILTERING AND TRANSIENT PROTECTION**

The ENMod system maintains the DC output bus voltage between 250 and 370 Vdc over the entire input-voltage range, which is compatible with all Vicor 300 V input converters. Autoranging automatically switches to the proper bridge or doubler mode at startup depending on the input voltage, eliminating the possibility of damage due to improper line connection. The ENMod system is rated at 575 W output power. These modules can serve as the AC front end for any number and combination of compatible converters as long as the maximum power rating is not exceeded.

**FARM3 MODULE PIN DESCRIPTIONS**

**Strap (ST) Pin.** In addition to input and output power pin connections, it is necessary to connect the Strap pin to the center junction of the series hold-up capacitors (C1, C2) for proper (autoranging) operation. Varistors V1 and V2 provide capacitor protection. The bleeder resistors (R1, R2) discharge the hold-up capacitors when power is switched off. Capacitors C7 and C8 are recommended if the hold-up capacitors are located more than 3 inches (75 mm) from the output pins.

**Enable (EN) Pin.** The Enable pin must be connected to the PC pin of all converter modules to disable the converters during power up. Otherwise, the converters would attempt to start while the hold-up capacitors are being charged through the current limiting thermistor, preventing the bus voltage from reaching the thermistor bypass threshold, thus disabling the power supply. The Enable output (the drain of an N channel MOSFET) is internally pulled up to 15 V through a 150 kΩ resistor. (Figure 9–11)

A signal diode should be placed close to and in series with the PC pin of each converter to eliminate the possibility of control interference between converters. The Enable pin switches to the high state (15 V) with respect to the SR pin to turn on the converters after the power-up inrush is over. The Enable function also provides input overvoltage protection for the converters by turning off the converters if the DC bus voltage exceeds 400 Vdc. The thermistor bypass switch opens if this condition occurs, placing the thermistor in series with the input voltage, reducing the bus voltage to a safe level while limiting input current in case the varistors conduct. The thermistor bypass switch also opens if a fault or overload reduces the bus voltage to less than 180 Vdc. (Figure 9–3)

**CAUTION:** There is no input to output isolation in the ENMods, hence the –Out of the ENMods and thus the –In of the downstream DC-DC converter(s) are at a high potential. If it is necessary to provide an external enable / disable function by controlling the DC-DC converter’s PC pin (referenced to the –In) of the converter an opto-isolator or isolated relay should be employed.

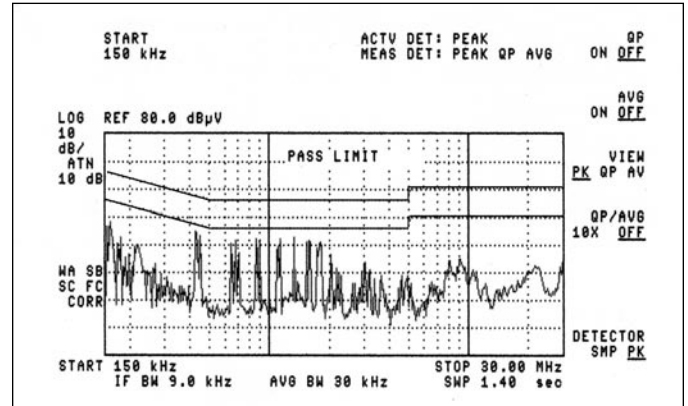

Figure 9–10a — Peak detection

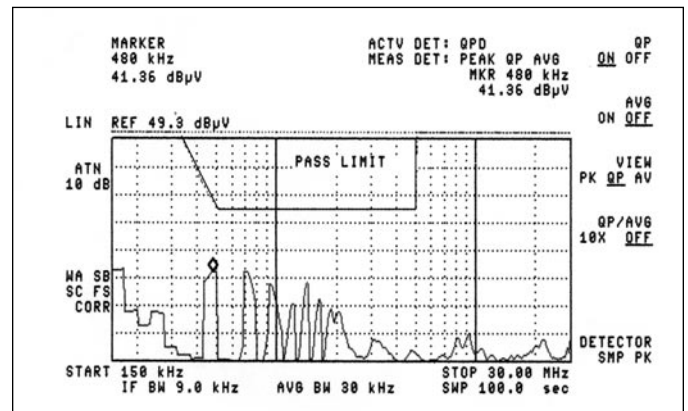

Figure 9–10b — Quasi-peak detection

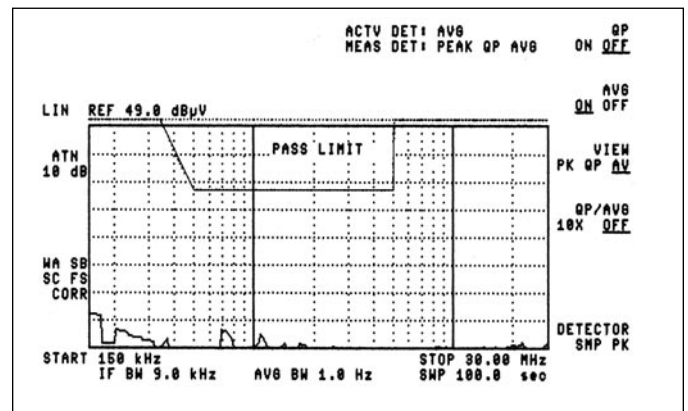

Figure 9–10c — Average detection

**Bus OK (BOK) Pin.** (Figure 9–12) The Bus OK pin is intended to provide early-warning power fail information and is also referenced to the SR pin.

**CAUTION:** There is no input-to-output isolation in the ENMods. It is necessary to monitor Bus OK via an optoisolator if it is to be used on the secondary (output) side of the converters. A line-isolation transformer should be used when performing scope measurements. Scope probes should never be applied simultaneously to the input and output as this will damage the module.

**L, N Pins.** Line and neutral input.

**+ / – Pins.** Positive and negative outputs.

**SR Pin.** Signal return for BOK and EN outputs.

### FOR MINIHAM MODULE PIN CONNECTIONS (Figure 9–1a)

**Filter.** (Figure 9–1b) The input EMI filter consists of differential and common-mode chokes, Y-capacitors (line-ground), and X-capacitors (line-line). This filter configuration provides sufficient common-mode and differential-mode insertion loss in the frequency range between 100 kHz and 30 MHz to comply with the Class B conducted emissions limit, as illustrated in Figures 9–10a thru 9–10c.

**Hold-up Capacitors.** Hold-up capacitor values should be determined according to output bus voltage ripple, power fail hold-up time, and ride-through time. (Figure 9–13) Many applications require the power supply to maintain output regulation during a momentary power failure of specified duration, i.e., the converters must hold-up or ride-through such an event while maintaining undisturbed output voltage regulation. Similarly, many of these same systems require notification of an impending power failure in order to allow time to perform an orderly shutdown.

The energy stored on a capacitor which has been charged to voltage  $V$  is:

$$\mathcal{E} = 1/2(CV^2) \quad (1)$$

where:  $\mathcal{E}$  = stored energy

$C$  = capacitance

$V$  = voltage across the capacitor

Energy is given up by the capacitors as they are discharged by the converters. The energy expended (the power-time product) is:

$$\mathcal{E} = P\Delta t = C(V_1^2 - V_2^2) / 2 \quad (2)$$

where:  $P$  = operating power

$\Delta t$  = discharge interval

$V_1$  = capacitor voltage at the beginning of  $\Delta t$

$V_2$  = capacitor voltage at the end of  $\Delta t$

Rearranging Equation 2 to solve for the required capacitance:

$$C = 2P\Delta t / (V_1^2 - V_2^2) \quad (3)$$

The power fail warning time ( $\Delta t$ ) is defined as the interval between Bus OK and converter shutdown (EN) as illustrated in Figure 9–13. The Bus OK and Enable thresholds are 205 V and 190 V, respectively. A simplified relationship between power fail warning time, operating power, and bus capacitance is obtained by inserting these constants in Equation (3):

$$C = 2P\Delta t / (205^2 - 190^2)$$

$$C = 2P\Delta t / (5,925)$$

It should be noted that the series combination ( $C_1$ ,  $C_2$ , Figure 9–1a) requires each capacitor to be twice the calculated value, but the required voltage rating of each capacitor is reduced to 200 V.

Allowable ripple voltage on the bus (or ripple current in the capacitors) may define the capacitance requirement. Consideration should be given to converter ripple rejection and resulting output ripple voltage.

Equation 3 is again used to determine the required capacitance. In this case,  $V_1$  and  $V_2$  are the instantaneous values of bus voltage at the peaks and valleys (Figure 9–13) of the ripple, respectively. The capacitors must hold up the bus voltage for the time interval ( $\Delta t$ ) between peaks of the rectified line as given by:

$$\Delta t = (\pi - \theta) / 2\pi f \quad (4)$$

where:  $f$  = line frequency

$\theta$  = rectifier conduction angle

The approximate conduction angle is given by:

$$\theta = \cos^{-1}(V_2 / V_1) \tag{5}$$

Another consideration in hold-up capacitor selection is their ripple current rating. The capacitors' rating must be higher than the maximum operating ripple current. The approximate operating ripple current (rms) is given by:

$$I_{rms} = 2P / V_{ac} \tag{6}$$

where: P = total output power

V<sub>ac</sub> = operating line voltage

Calculated values of bus capacitance for various hold-up time, ride-through time, and ripple voltage requirements are given as a function of operating power level in Figures 9-14, 9-15, and 9-16, respectively.

**EXAMPLE**

In this example, the output required from the DC-DC converter at the point of load is 12 Vdc at 320 W. Therefore the output power from the ENMods would be 375 W (assuming a converter efficiency of 85%). The desired hold-up time is 9 ms over an input range of 90 to 264 Vac.

**Determining Required Capacitance for Power Fail Warning.** Figure 9-14 is used to determine capacitance for a given power fail warning time and power level, and shows that the total bus capacitance should be at least 820 μF. Since two capacitors are configured in series, each capacitor should be at least 1,640 μF. Note that warning time is not dependent on line voltage. A hold-up capacitor calculator is available on the Vicor website, at [vicorpower.com/hubcalc](http://vicorpower.com/hubcalc).

**Determining Ride-through Time.** Figure 9-15 illustrates ride-through time as a function of line voltage and output power, and shows that at a nominal line of 90 Vac, ride-through would be 68 ms. Ride-through time is a function of line voltage.

**Determining Ripple Voltage on the Hold-up Capacitors.** Figure 9-16 is used to determine ripple voltage as a function of operating power and bus capacitance, and shows that the ripple voltage across the hold-up capacitors will be 12 Vp-p.

**Determining the Ripple on the Output of the DC-DC Converter.** Figure 9-17 is used to determine the ripple rejection of the DC-DC converter and indicates a ripple rejection of approximately 60 dB for a 12 V output. Since the ripple on the bus voltage is 12 Vac and the ripple rejection of the converter is 60 dB, the output ripple of the converter due to ripple on its input (primarily 120 Hz) will be 12 mVp-p.

A variety of hold-up capacitor options are available. Please visit our website at [vicorpower.com/hub](http://vicorpower.com/hub).

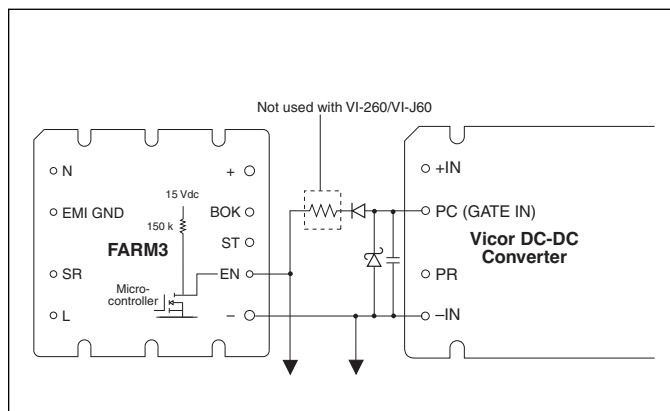

Figure 9-11 — Enable (EN) function

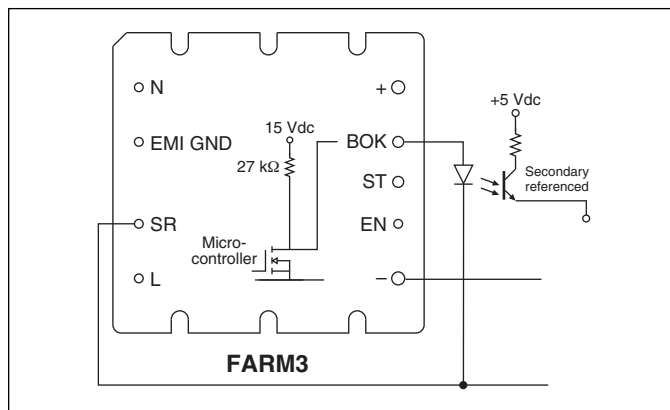

Figure 9-12 — Bus OK (BOK) isolated power status indicator

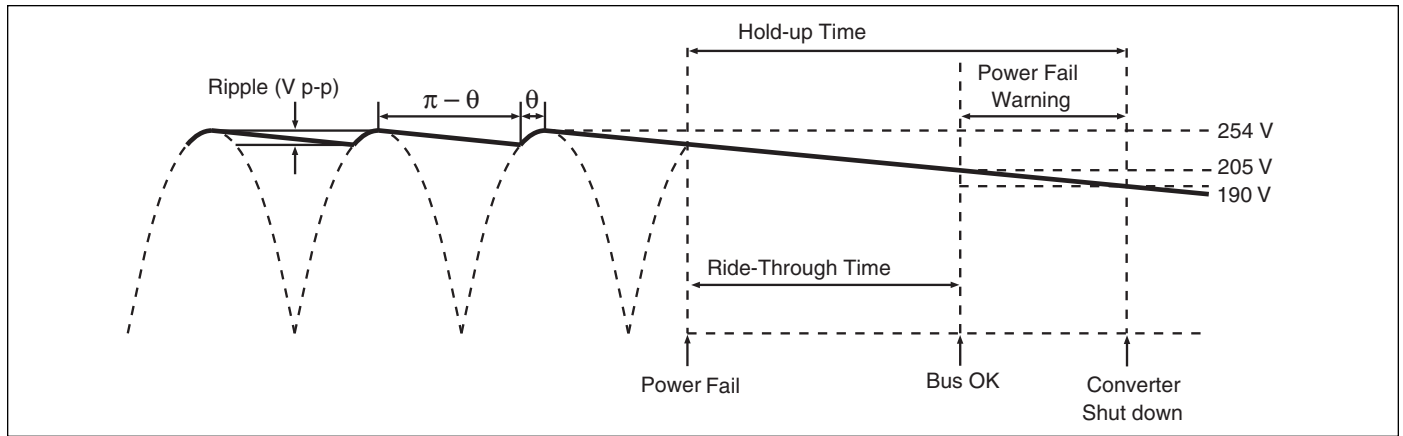

Figure 9-13 — General timing diagram of bus voltage following interruption of the AC mains

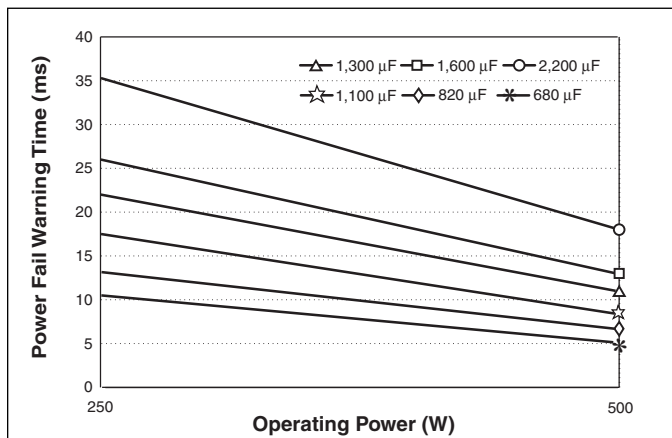

Figure 9-14 — Power fail warning time vs. operating power and total bus capacitance, series combination of C1, C1 (Figure 9-1a)

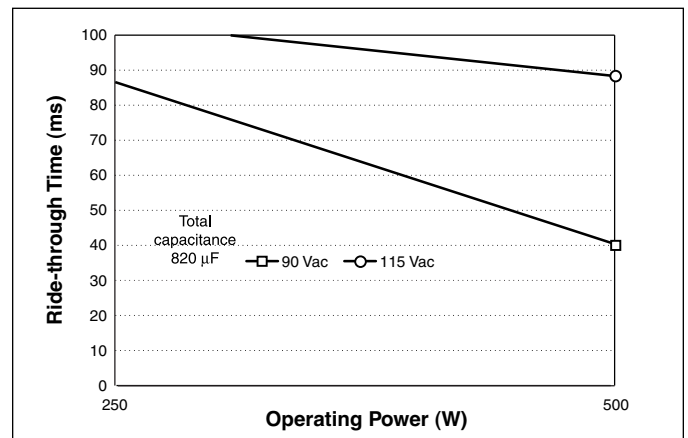

Figure 9-15 — Ride-through time vs. operating power

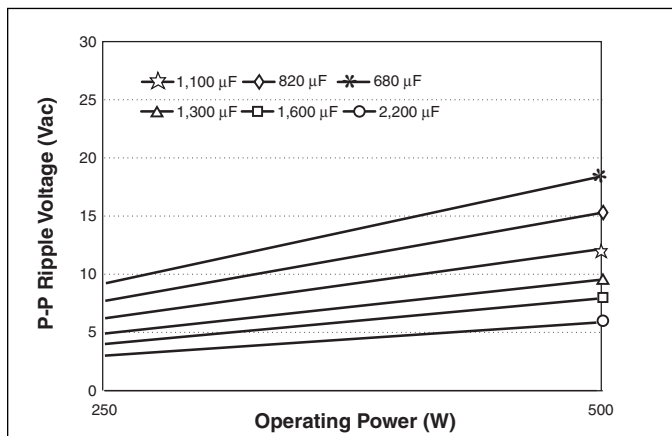

Figure 9-16 — Ripple voltage vs. operating power and bus capacitance, series combination of C1, C1 (Figure 9-1a)

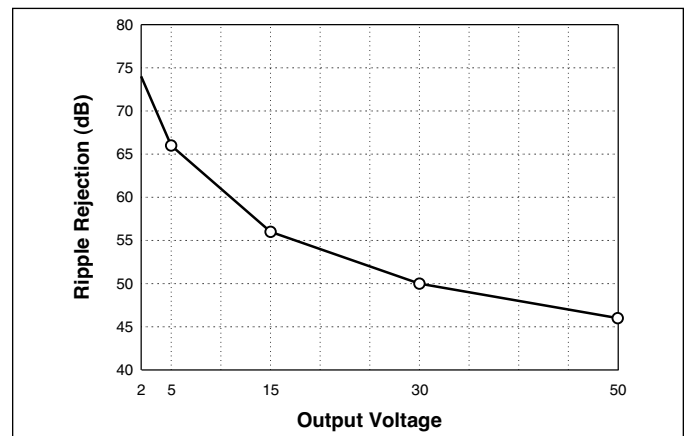

Figure 9-17 — Converter ripple rejection vs. output voltage (Typical)

**THE HIGH-BOOST HARMONIC ATTENUATOR MODULE COMPATIBLE WITH V375, VI-26x AND VI-J6x FAMILIES**

The High-Boost Harmonic Attenuation Module (HAM) consists of a full-wave rectifier, a high-frequency zero-current-switching (ZCS) boost converter, active inrush current limiting, short-circuit protection, control, and housekeeping circuitry (Figure 10–1). The incoming AC line is rectified and fed to the boost converter. The control circuitry varies the operating frequency of the boost converter to regulate and maintain the output voltage of the HAM above the peak of the incoming line, while forcing the input current to follow the waveshape and phase of the line voltage. A power factor better than 0.99 is achieved (Figure 10–2). Operating efficiency of the boost converter is optimized at any incoming line voltage by an adaptive output voltage control scheme.

The output voltage of the HAM is a function of incoming AC line voltage (Figure 10–3). On a nominal 115 Vac line, the output voltage of the HAM is 280 Vdc — well within the input operating voltage range of Vicor V375 DC-DC converters. Above 180 V input, the output voltage linearly increases with input voltage. At 230 Vac the delivered voltage will be approximately 365 V. For any given input line voltage, the HAM maintains enough headroom between the output voltage and peak input voltage to ensure high quality active power factor correction without sacrificing operating efficiency.

The HAMD version does not contain an internal bridge rectifier and is intended for configuring higher power arrays with Booster versions, referred to as the VI-BAMD (Figure 10–5).

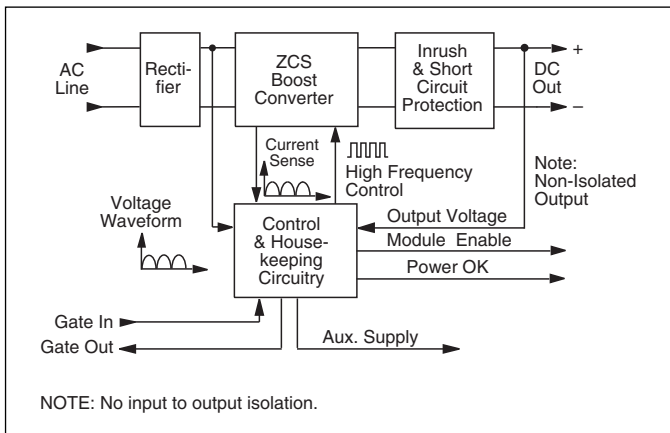

Figure 10–1 — HAM block diagram (HAMD version has the rectifier block deleted.)

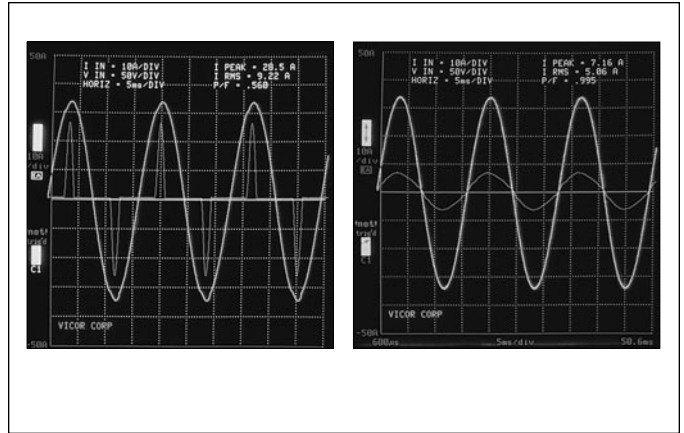

Figure 10–2 — Input voltage and current wave forms, without and with power factor correction.

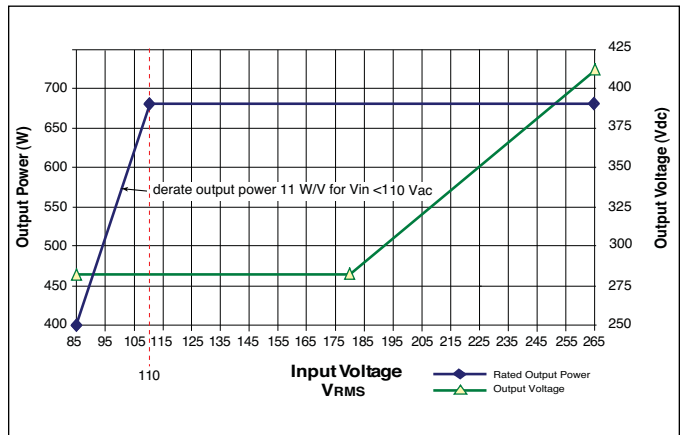

Figure 10–3 — Output voltage and power rating vs. input voltage

**L1 and L2/IN (HAM) Pin.** An appropriate line filter is required to limit conducted emissions and ensure reliable operation of the HAM, see page 51. Connect single phase AC mains to the input of the line filter via a 10 A, 250 V fuse. Connect the output of the filter to L1 and L2/N of the HAM. Do not put an X-capacitor across the input of the HAM or use a line filter with an X-capacitor on its output as power factor correction may be impacted.

**+IN, -IN (HAMD, BAMD) Pin.** These pins are connected to the output of the external bridge rectifier in HAMD / BAMD configurations (Figure 10–5).

**GATE IN (HAM) Pin.** The user should not make any connection to this pin.

**GATE IN (HAMD) Pin.** This pin provides line voltage envelope and phase information for power factor correction. This connection must be made through the synchronization diodes between the line filter and bridge rectifier (Figure 10–5).

**GATE IN (BAMD) Pin.** The Gate In pin is an interface pin to the Gate Out pin of a HAMD or BAMD depending on configuration. The user should not make any other connection to this pin.

**GATE OUT Pin.** The Gate Out pin is a synchronization pin for HAMD/BAMD arrays; the user should not make any other connection to this pin.

**+OUT and -OUT Pin.** Connect the +OUT of the HAM to the +IN of the respective Vicor DC-DC converters with the recommended fuse. Connect the -OUT of the HAM to the -IN of the converters. In addition, an external hold-up capacitor of 1,000  $\mu\text{F}$  with a minimum voltage rating of 450 Vdc, is required (across the output of the HAM) for 16 ms ride through time at full power (500  $\mu\text{F}$  for half power, etc). This capacitor must be in close proximity to the HAM. Do not exceed 3,000  $\mu\text{F}$  of total output capacitance. Lower values of capacitance may be used for reduced hold up requirements, but not less than 500  $\mu\text{F}$ . Lower capacitance values may degrade power factor specifications.

**Auxiliary Supply (A/S) Pin.** The HAM provides a low voltage non isolated output Auxiliary Supply (A/S) that may be used to power primary side control and monitoring circuitry. This output is 19 – 23 Vdc, referenced to -OUT, at 3 mA max. Do not overload or short this output as the HAM will fail. A typical use for A/S is to power an optical coupler that isolates the Power OK signal (Figure 10-6).

**Enable Output (E/O) Pin.** The Enable Output (E/O) is used to inhibit the DC-DC converters at start up until the hold up capacitors are charged, at which time Enable is asserted high (open state, Figure 10-8). If the AC line fails, E/O goes low when the DC output of the HAM drops below 250 Vdc.

E/O must be connected to the Gate Input of all VI-26x and VI-J6x drivers and/or the PC pin of the V375 DC-DC converters (Figure 10-4); failure to do so may cause the converters to toggle on and off. If an external load is connected directly to the output of the HAM, do not apply the load until the output hold up capacitor(s) are fully charged.

In applications using VI-26x drivers and VI-26x boosters, the E/O pin should be connected to the Gate In pin of the driver module only, it is not necessary to connect this pin to boosters as they are controlled by their respective driver.

The E/O pin ancillary circuitry illustrated in Figures 10-4 and 10-5 provides transient immunity. The illustrated circuitry is the minimum required, see Figures 10-4 and 10-5.

**Power OK (P/OK) Pin.** Power OK is a monitor signal that indicates the status of the AC mains and the DC output voltage of the HAM. P/OK is asserted (active low) when the output bus voltage is within normal operating range ( $>270$  Vdc) and 20 – 25 ms after DC-DC converters are enabled by the E/O signal of the HAM. This provides sufficient time for the converters to turn on and their output(s) to stabilize prior to P/OK being asserted, (Figure 10-9). For momentary interruptions of AC power, the HAM will provide at least 16 ms of ride through or hold up time (with 1,000  $\mu\text{F}$  output capacitor). On loss of power or brownout, (when the HAM output voltage drops below 270 Vdc) the P/OK signal will go to an open circuit state (Figure 10-7), signaling an impending loss of input power to the converter modules. P/OK will provide power fail warning at least 1 ms prior to converter shut down. When the HAM output voltage drops below 250 Vdc the converters are disabled via Enable Output (E/O).

## SAFETY NOTES

Each HAM, HAMD or BAMD module must be preceded by a safety agency recognized fast-blow 10A 3AG fuse.

The HAM is not isolated from the line – either input or output; a line isolation transformer must be used when making scope measurements. HAMs do not provide input to output isolation. Differential probes should be used when probing the input and output simultaneously to avoid destructive ground loops.

## PROTECTIVE FEATURES

**Over Temperature Shut Down.** The HAM is designed to shut down when the temperature of the baseplate exceeds 90°C. Do not operate the HAM above its maximum operating temperature of 85°C.

**Short Circuit Protection.** The HAM contains output short circuit protection. Operation of this function does not clear the input fuse and the output will resume normal operation after removal of the fault. A short period of time may be required to allow for cooling of an internal temperature sensor.

**Output Over Voltage Protection.** The HAM contains output over voltage protection. In the event the output voltage exceeds approximately 420 Vdc, the boost will decrease to maintain 420 Vdc on the output. When the peak of the AC line exceeds 420 V (approximately 293 Vac) the boost will have been reduced to zero and the E/O line will be pulled low shutting down the converters. Beyond this the protection circuit will be enabled and the output voltage will decrease.

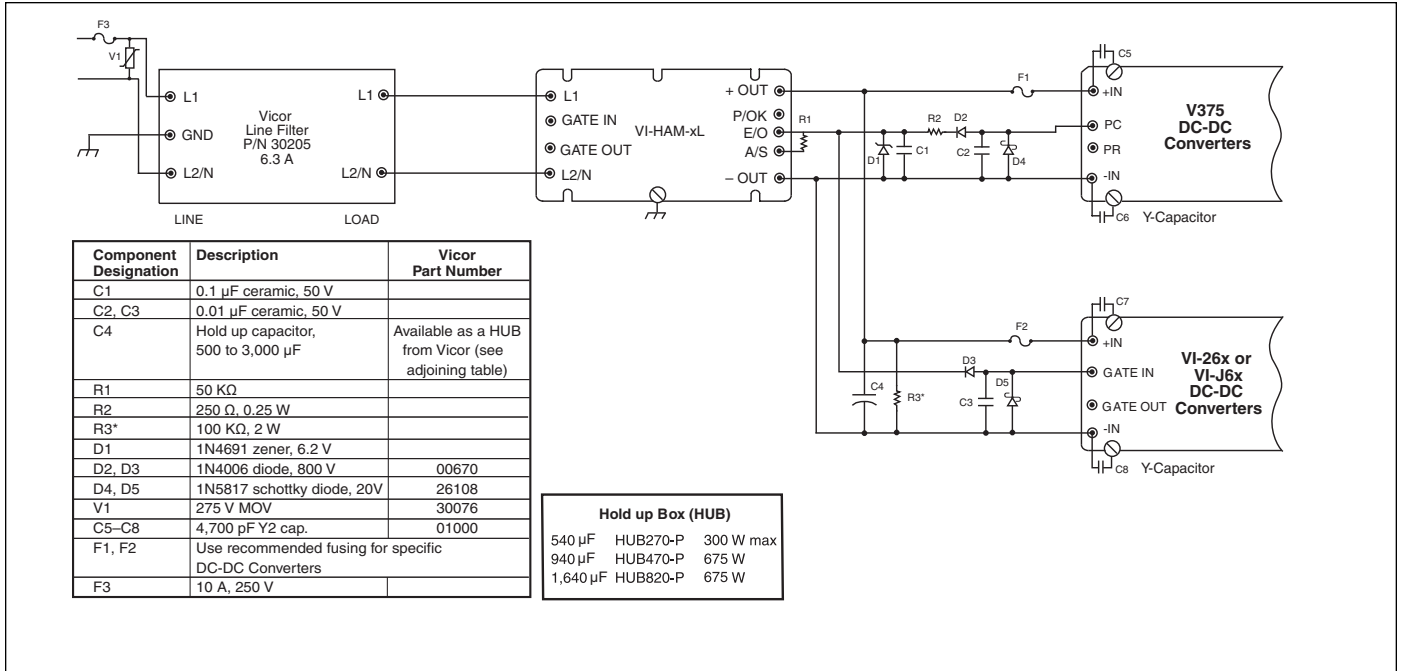

Figure 10-4 — Connection diagram HAM / DC-DC converter

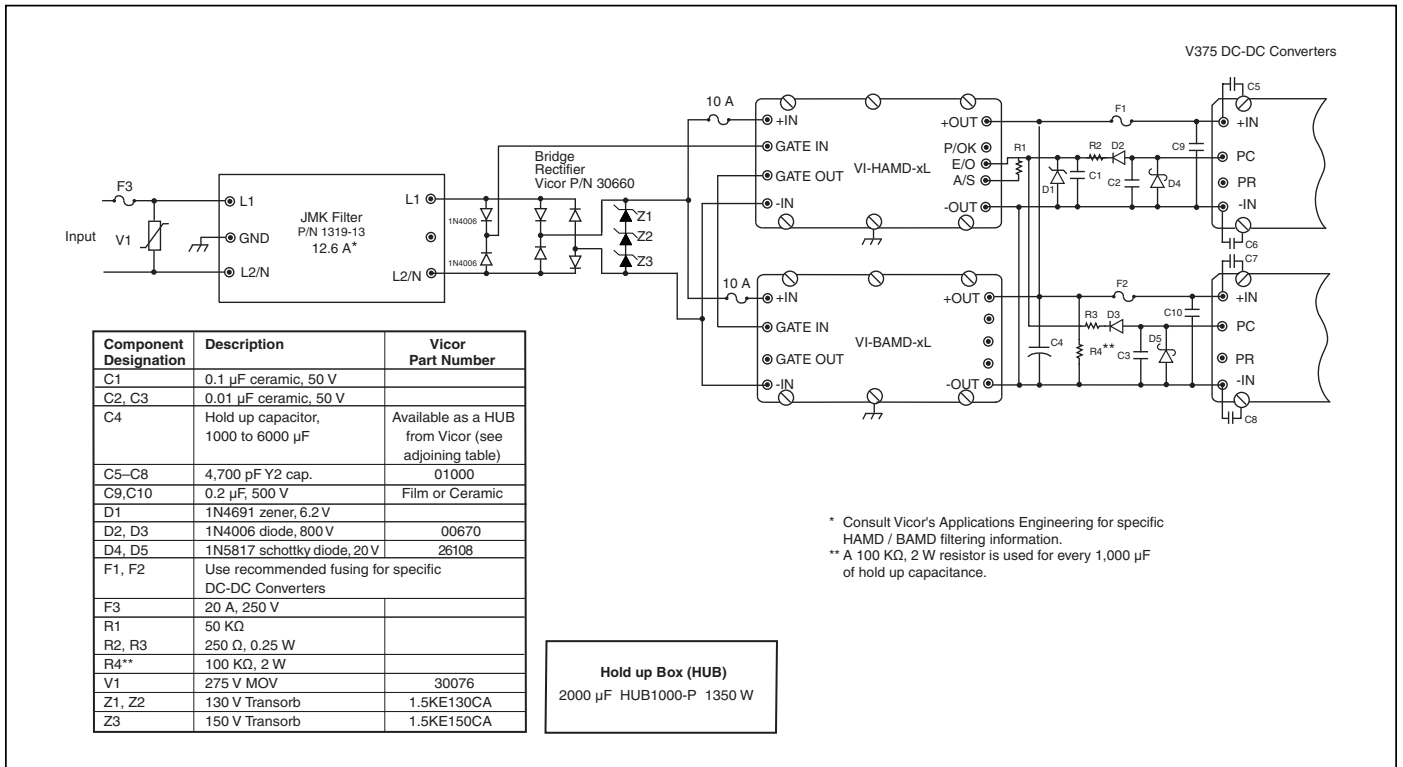

Figure 10-5 — Connection diagram, HAMD / BAMD / V375 DC-DC converters

HAMD-CL Driver HAM: No internal bridge rectifier or synchronization diodes.

BAMD-CL Booster HAM: Companion module to HAMD-CM used for additional output power. No internal bridge rectifier.

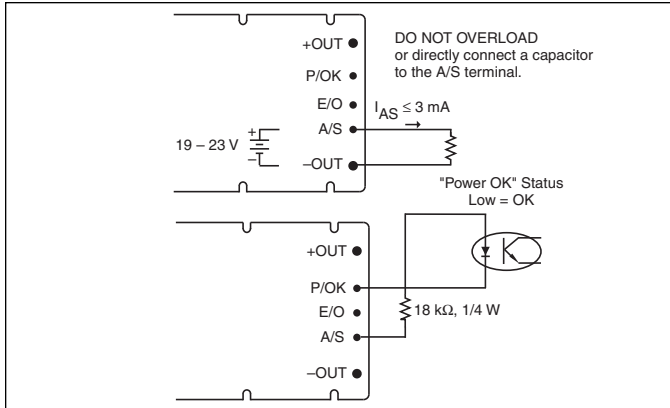

Figure 10-6 — Auxiliary Supply (A/S)

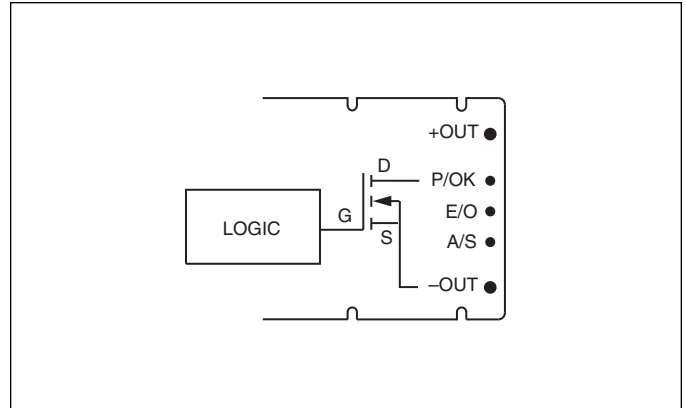

Figure 10-7 — Power OK (P/OK)

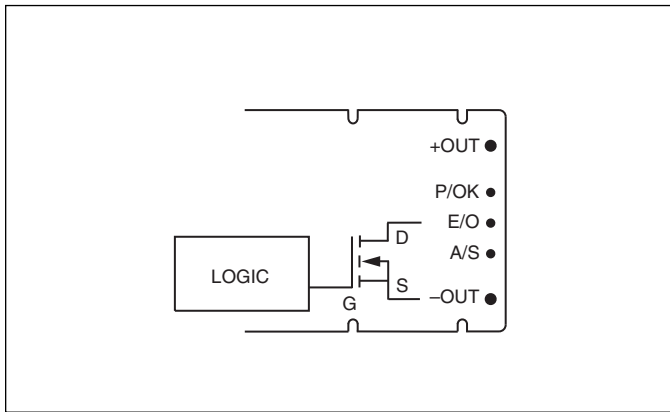

Figure 10-8 — Enable Output (E/O)

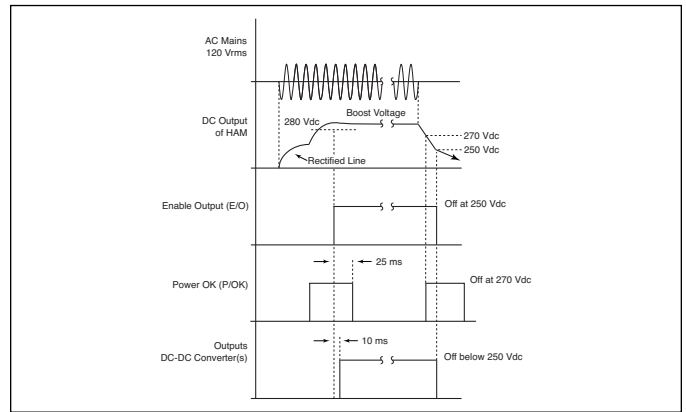

Figure 10-9 — Start-up / shut-down timing diagram

**LINE FILTER FOR HIGH BOOST HAM**

A line filter is required to provide attenuation of conducted emissions generated by the HAM module and to protect it from line transients. It also presents a well defined high frequency AC line impedance to the input of the HAM. To meet the listed specifications, Vicor’s P/N 30205 line filter/transient suppressor or equivalent must be used, see Figure 10-10. The addition of a MOV external to this filter is required to meet normal mode transient surge requirements.

For applications using HAMD + BAMD or where the user desires to construct a custom HAM filter, the filter should be designed following Figure 10-10, the schematic of Vicor’s P/N 30205 filter. The current carrying capability of the inductors must be scaled proportionally to the number of HAM modules used. Inductance values must be selected according to Table 10-1. These limits are to ensure proper operation of the HAM and do not guarantee a system will meet conducted emissions specifications.

For applications requiring magnetic field shielding, do not place a ferrous EMI shield over the plastic cover of the HAM module. This can cause thermal problems due to induction heating effects.

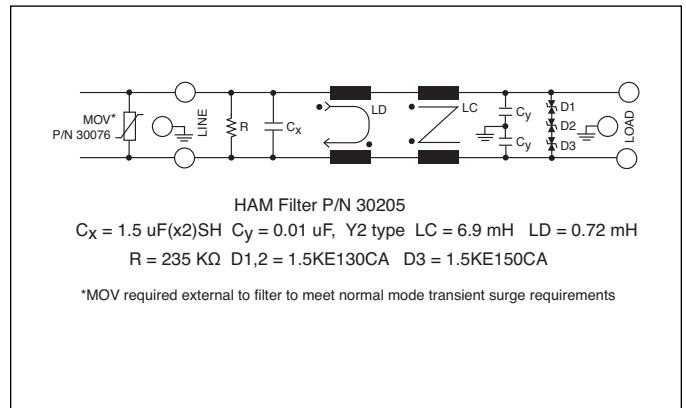

Figure 10-10 — Recommended HAM filter

Parameter	Min	Typ	Max	Unit
Differential Mode Inductance (LD)	0.2	0.35	0.75	mH
Common Mode Inductance (LC)	3	6		mH

Table 10-1 — HAM filter inductance range

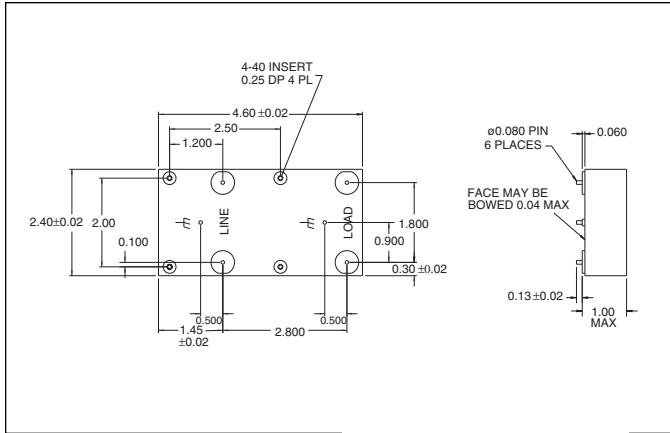

Figure 10-11 — HAM filter mechanical diagram

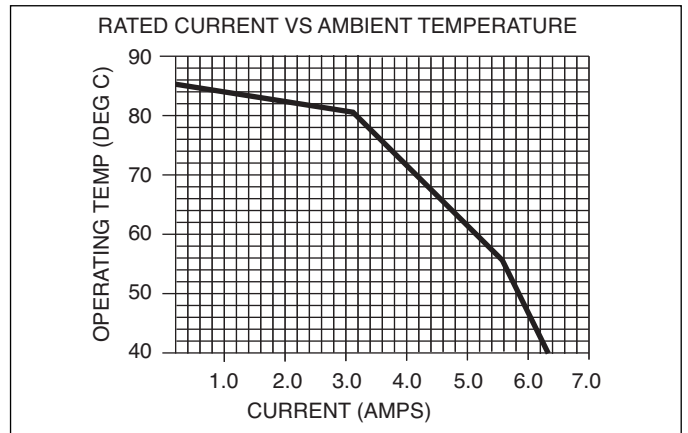

Figure 10-12 — HAM filter's current rating vs. temperature

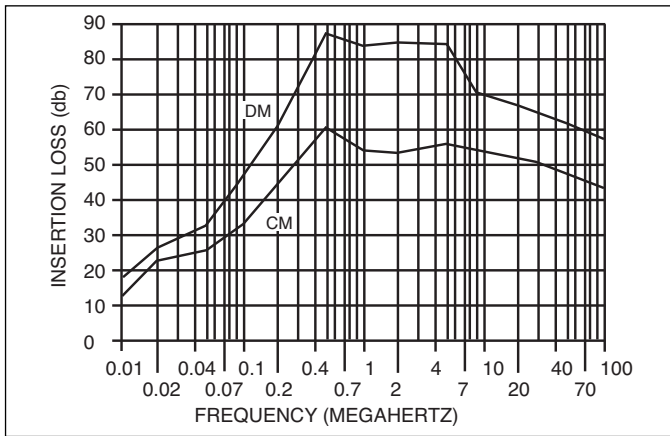

Figure 10-13 — HAM filter insertion loss vs. frequency

Parameter	Min	Typ	Max	Unit
Operating voltage	85		250	Vac
Operating temperature (See Fig.10-12)	-20		50	°C
Leakage current at 264 Vac, 63 Hz (Either line to earth)			1.2	mA
Operating current			6.3	A
Dielectric withstand (line – case)			1500	Vac
Residual voltage after 1 sec.			34	V
Operating frequency	50		60	Hz
Agency Approvals		UL, CSA, TÜV		

Table 10-2 — HAM filter part #30205 specifications

**Description:**

The FIAM family of front-end modules (Figure 11–1) provides EMI filtering, transient protection, and inrush current limiting in DC-DC applications. The FIAM enables designers using Vicor Maxi, Mini, and Micro DC-DC converters, and in select cases V•I Chip based devices, to meet the transient immunity and EMI requirements of the standards referenced in the respective model datasheet.

**Theory of Operation:**

Refer to the simplified FIAM block diagram Figure 11-2.

Internally, the FIAM employs a transient suppressor directly across the input. A passive EMI filter that is tuned to attenuate both common-mode and differential-mode conducted emissions follow this.

When the FIAM ON/OFF control pin is tied to - OUT the device is set to "ON" and will provide an output upon application of input voltage.

When power is applied, the charge pump / control circuit drives the gate of the MOSFET in series with the positive rail (Q1). The charge pump limits the time rate of change of the gate bias voltage, which results in a controlled voltage ramp-up - this limits the rate at which the external output capacitor is charged, thereby limiting the system inrush current.

During normal operation Q1 is fully enhanced - essentially a closed switch.

Surge protection is accomplished by robbing gate charge of the Q1 by the bottom MOSFET Q2. During this condition, the source terminal of the Q1 follows the gate, offset by the gate threshold voltage. A transient surge event at the input, or drain terminal of the Q1 is therefore attenuated and absorbed by Q1 while in the source follower mode. As a result, the transient surge is not propagated to the output of the FIAM.

Removing the ON/OFF connection shuts down the charge pump and turns off Q1.

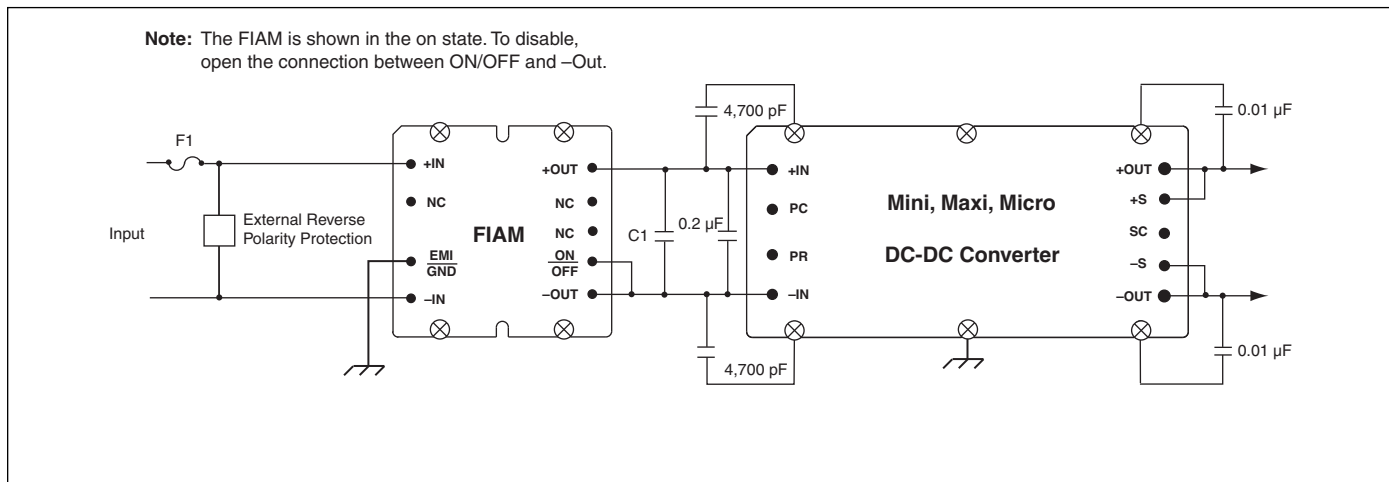

Figure 11–1 — Typical application (FIAM)

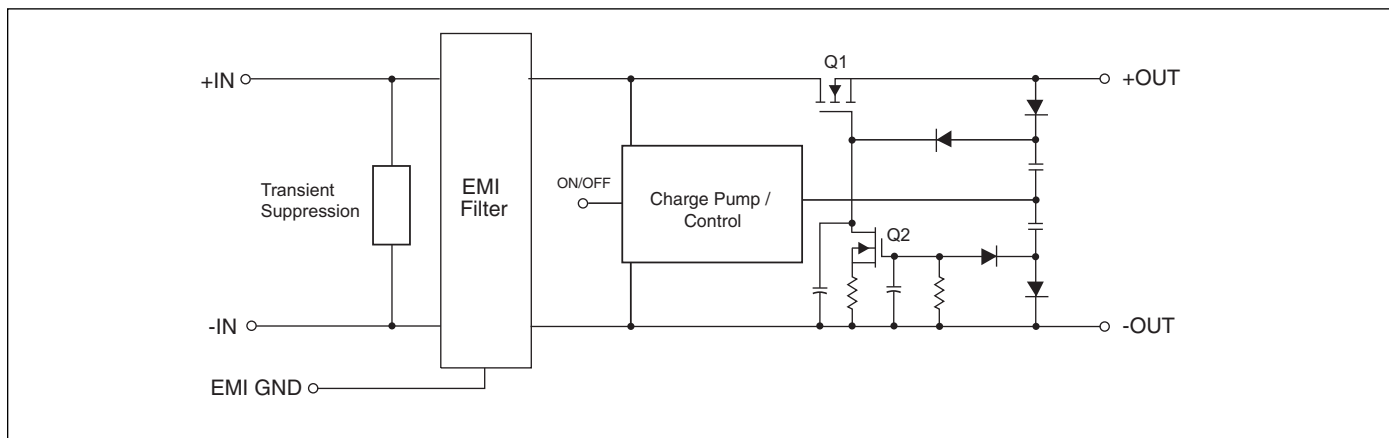

Figure 11–2 — Block diagram (FIAM)

	<b>FIAM1</b>	<b>FIAM2</b>	<b>M-FIAM3</b>	<b>Notes</b>
Input voltage	36 – 76 Vdc	36 – 76 Vdc	180 – 375 Vdc	Continuous
Recommended fusing (F1):	Bussman ABC-10	Bussman ABC-20	Bussman ABC-3	
Output current:	10 A	20 A	3 A	Maximum
External capacitance (C1)	10 µF min – 150 µF max	100 µF min – 330 µF max	10 µF min – 22 µF max	
Inrush limiting	0.014 A/µF	0.014 A/µF	0.018 A/µF	Maximum
EMI/RFI	Bellcore GR-001089-Core, EN55022 Class B, FCC Part 15 Class B	Bellcore GR-001089-Core, EN55022 Class B, FCC Part 15 Class B	MIL-STD-461E, CE101 CE102, CS101, CS114 CS115, CS116	
Transient immunity	Bellcore TR-NWT-0004999, ETS 300 386-1, Class 2	Bellcore TR-NWT-0004999, ETS 300 386-1, Class 2	Exceeds limits of MIL-STD-704E/F	
Mini package size	2.28" x 2.2" x 0.5"	2.28" x 2.2" x 0.5"	2.28" x 2.2" x 0.5"	

	<b>M-FIAM5B</b>	<b>M-FIAM9</b>	<b>Notes</b>
Input voltage	14 – 36 Vdc	10 – 36 Vdc	Continuous
Recommended fusing (F1):	Bussman ABC-20	Bussman ABC-20	
Output current:	20 A	18 A	Maximum
External capacitance (C1)	330 µF min – 1000 µF max	330 µF min – 1000 µF max	
Inrush limiting	0.007 A/µF	0.007 A/µF	Maximum
EMI/RFI	MIL-STD-461E, CE101 CE102, CS101, CS114 CS115, CS116	MIL-STD-461E, CE101 CE102, CS101, CS114 CS115, CS116	
Transient immunity	50 V Max. 12.5 ms per MIL-STD-704E/F, cont. operation	100 Vdc 50 ms per MIL-STD-1275A/B/D, 250 Vdc 70 µs per MIL-STD-1275A/B/D, 70 Vdc 20 ms per MIL-STD-704A. 50 Vdc 12.5 ms per MIL-STD-704E/F, cont. operation	
Mini package size	2.28" x 2.2" x 0.5"	2.28" x 2.2" x 0.5"	

Table 11-1 — FIAM Family Specifications (See specific data sheets for more detail)

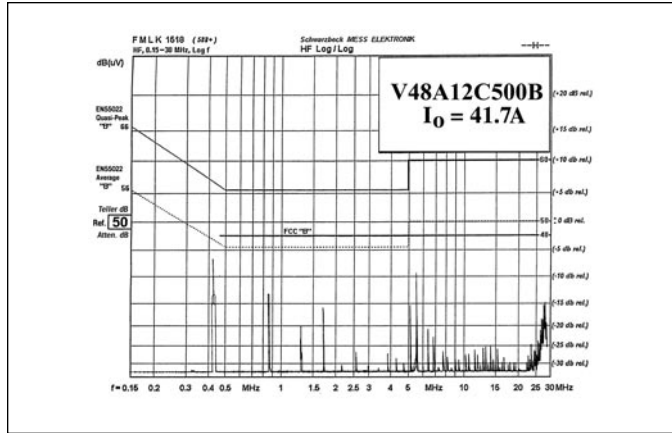

Figure 11-3 — FIAM and model V48A12C500B DC-DC converter Conducted Emissions Typical

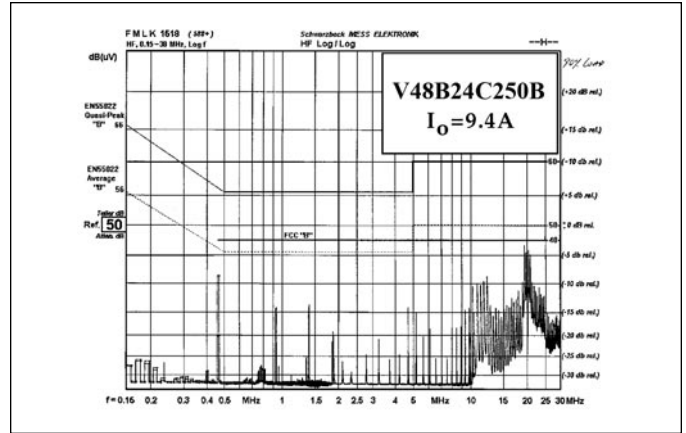

Figure 11-4 — FIAM and model V48B24C250B DC-DC converter Conducted Emissions Typical

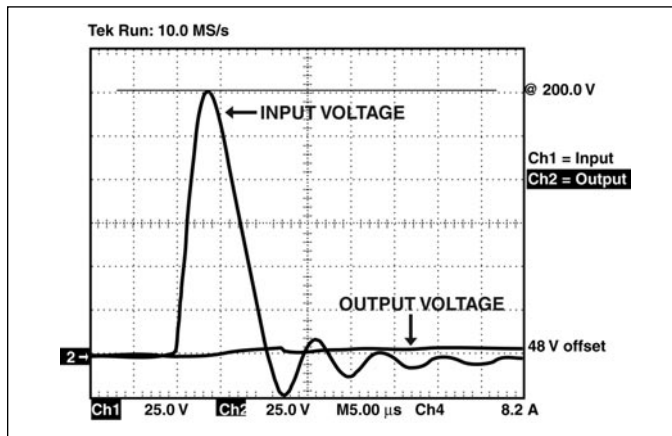

Figure 11-5 — Transient immunity: FIAM output response to an input transient Typical

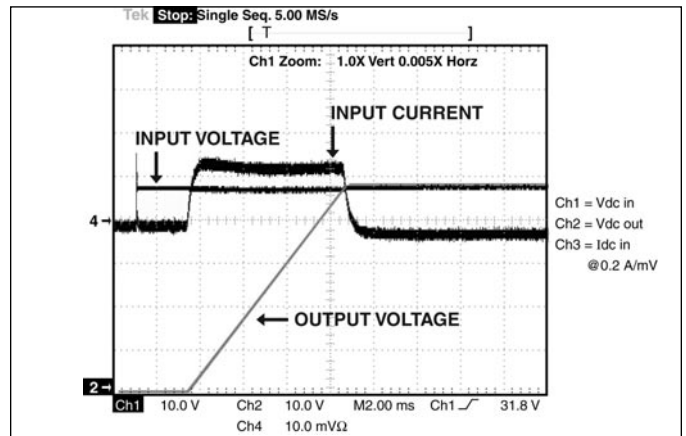

Figure 11-6 — Inrush limiting: Inrush current with 330  $\mu$ F external capacitance Typical

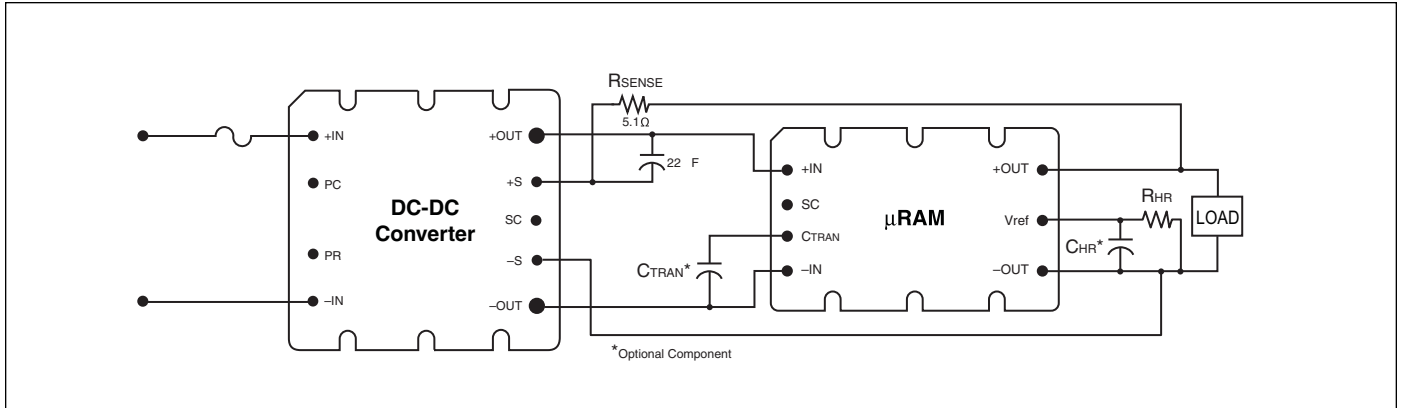

Figure 12-1a — Typical configuration using remote sense

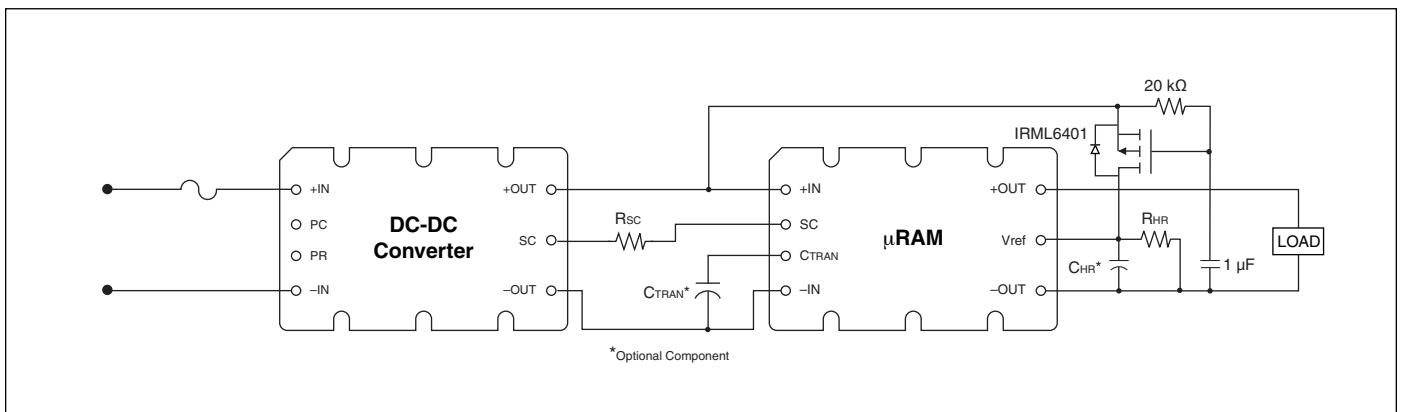

Figure 12-1b — Typical configuration using SC control (Optional  $C_{HR}$ , 25  $\mu\text{F}$  maximum in SC configuration.)

## FUNCTIONAL DESCRIPTION

The MicroRAM has an internal passive filter, (Figure 12-2) that effectively attenuates ripple in the 50 kHz to 1 MHz range. An active filter provides attenuation from low frequency up to the 1 MHz range. The user must set the headroom voltage of the active block with the external  $R_{HR}$  resistor to optimize performance. The MicroRAM must be connected as shown in Figures 12-1a or 12-1b depending on the load-sensing method. The transient load current performance can be increased by the addition of optional  $C_{TRAN}$  capacitance to the  $C_{TRAN}$  pin. The low-frequency ripple attenuation can be increased by addition of optional  $C_{HR}$  capacitance to the  $V_{REF}$  pin as shown in Figures 12-3a and 12-3b.

Transient load current is supplied by the internal  $C_{TRAN}$  capacitance, plus optional external capacitance, during the time it takes the converter loop to respond to the increase in load. The MicroRAM's active loop responds in roughly one microsecond to output voltage perturbations. There are limitations to the magnitude and the rate of change of the transient current that the MicroRAM can sustain while the converter responds. See Figures 12-8 through

12-16 for examples of dynamic performance. A larger headroom voltage setting will provide increased transient performance, ripple attenuation, and power dissipation while reducing overall efficiency. (Figures 12-4a, 12-4b, 12-4c, and 12-4d)

The active loop senses the output current and reduces the headroom voltage in a linear fashion to approximate constant power dissipation of MicroRAM with increasing loads. (Figures 12-7, 12-8 and 12-9) The headroom setting can be reduced to decrease power dissipation where the transient requirement is low and efficient ripple attenuation is the primary performance concern.

The active dynamic headroom range is limited on the low end by the initial headroom setting and the maximum expected load. If the maximum load in the application is 10 A, for example, the 1 A headroom can be set 75 mV lower to conserve power and still have active headroom at the maximum load current of 10 A. The high end or maximum headroom range is limited by the internal ORing diode function.

The SC or trim-up function can be used when remote sensing is not available on the source converter or is not desirable. It is specifically designed for converters with a 1.23 V reference and a 1 k $\Omega$  input impedance like Vicor Maxi, Mini, Micro converters. In comparison to remote sensing, the SC configuration will have an error in the load voltage versus load current. It will be proportional to the output current and the resistance of the load path from the output of the MicroRAM to the load.

The ORing feature prevents current flowing from the output of the MicroRAM back through its input terminal in a redundant system configuration in the event that a converter output fails. When the converter output supplying the MicroRAM droops below the ORed output voltage potential of the redundant system, the input of the MicroRAM is isolated from its output. Less than 50 mA will flow out of the input terminal of the MicroRAM over the full range of input voltage under this condition.

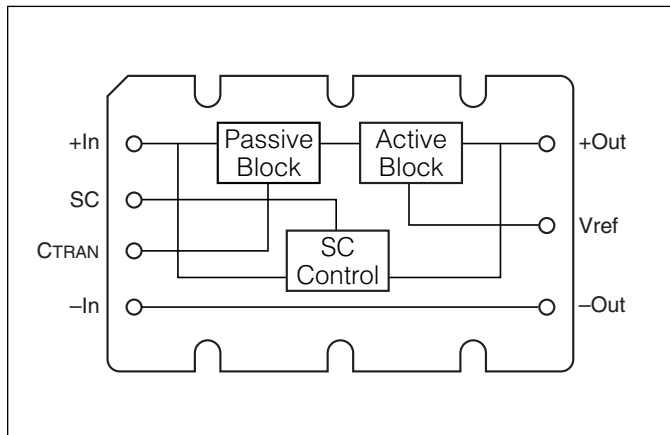

Figure 12-2 — MicroRAM block diagram

Load capacitance can affect the overall phase margin of the MicroRAM active loop as well as the phase margin of the converter loop. The distributed variables such as inductance of the load path, the capacitor type and value as well as its ESR and ESL also affect transient capability at the load. The following guidelines should be considered when point-of-load capacitance is used with the MicroRAM in order to maintain a minimum of 30 degrees of phase margin.

- Using ceramic load capacitance with <math><1\text{ m}\Omega</math> ESR and <math><1\text{ nH}</math> ESL:
  - 20  $\mu\text{F}$  to 200  $\mu\text{F}$  requires 20 nH of trace / wire load path inductance
  - 200  $\mu\text{F}$  to 1,000  $\mu\text{F}$  requires 60 nH of trace / wire load path inductance
- For the case where load capacitance is connected directly to the output of the MicroRAM, i.e. no trace inductance, and the ESR is >1 m $\Omega$ :
  - 20  $\mu\text{F}$  to 200  $\mu\text{F}$  load capacitance needs an ESL of >50 nH
  - 200  $\mu\text{F}$  to 1,000  $\mu\text{F}$  load capacitance needs an ESL of >5 nH
- Adding low ESR capacitance directly at the output terminals of MicroRAM is not recommended and may cause stability problems.
- In practice, the distributed board or wire inductance at a load or on a load board will be sufficient to isolate the output of the MicroRAM from any load capacitance and minimize any appreciable effect on phase margin.

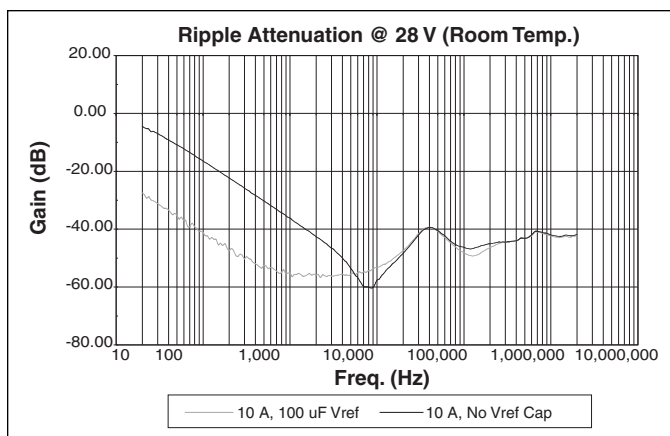

Figure 12-3a — The small signal attenuation performance as measured on a network analyzer with a typical module at 28 V and 10 A output. The low frequency attenuation can be enhanced by connecting a 100  $\mu\text{F}$  capacitor,  $C_{HR}$ , to the  $V_{REF}$  pin as shown in Figures 12-1 and 12-2.

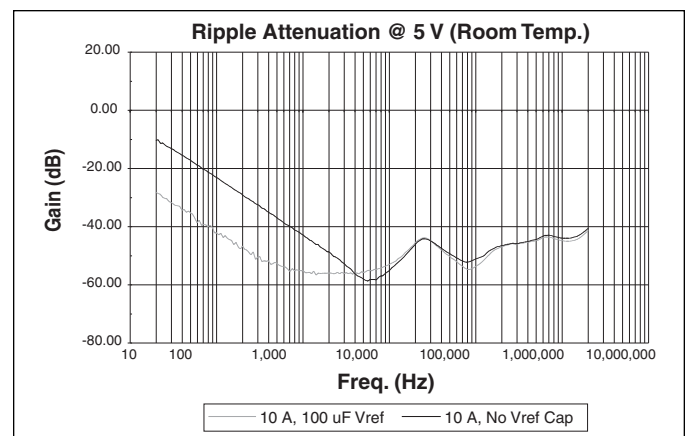

Figure 12-3b — The small signal attenuation performance as measured on a network analyzer with a typical module at 5 V and 10 A. The low frequency attenuation can be enhanced by connecting a 100  $\mu\text{F}$  capacitor,  $C_{HR}$ , to the  $V_{REF}$  pin as shown in Figures 12-1 and 12-2.

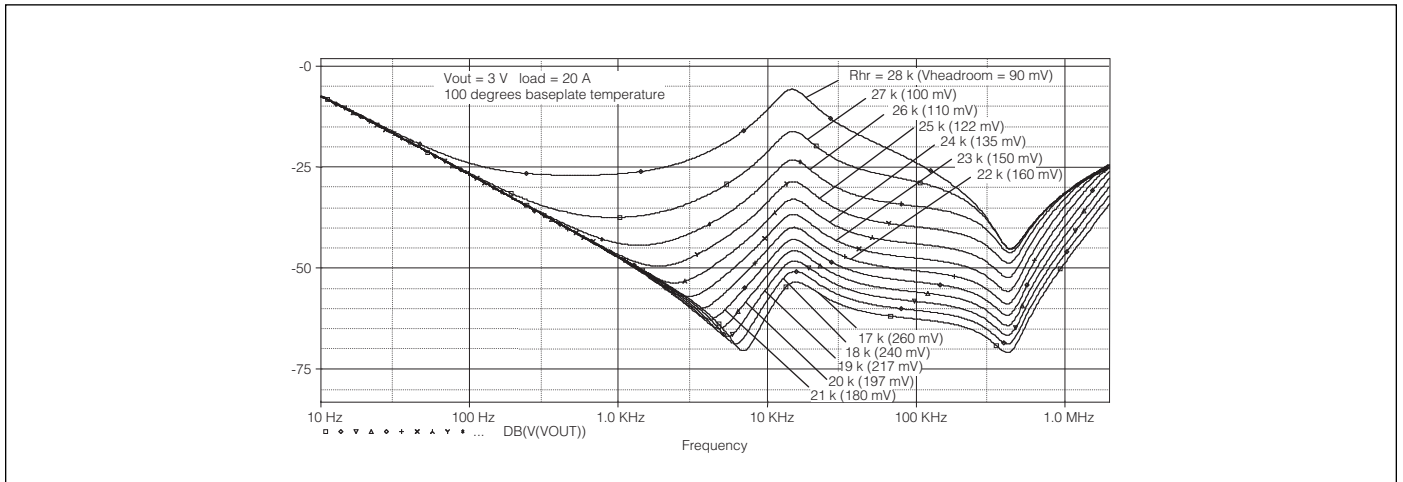

Figure 12-4a — Graph of simulated results demonstrating the tradeoff of attenuation vs. headroom setting at 20 A and a equivalent 100°C baseplate temperature at 3 V.

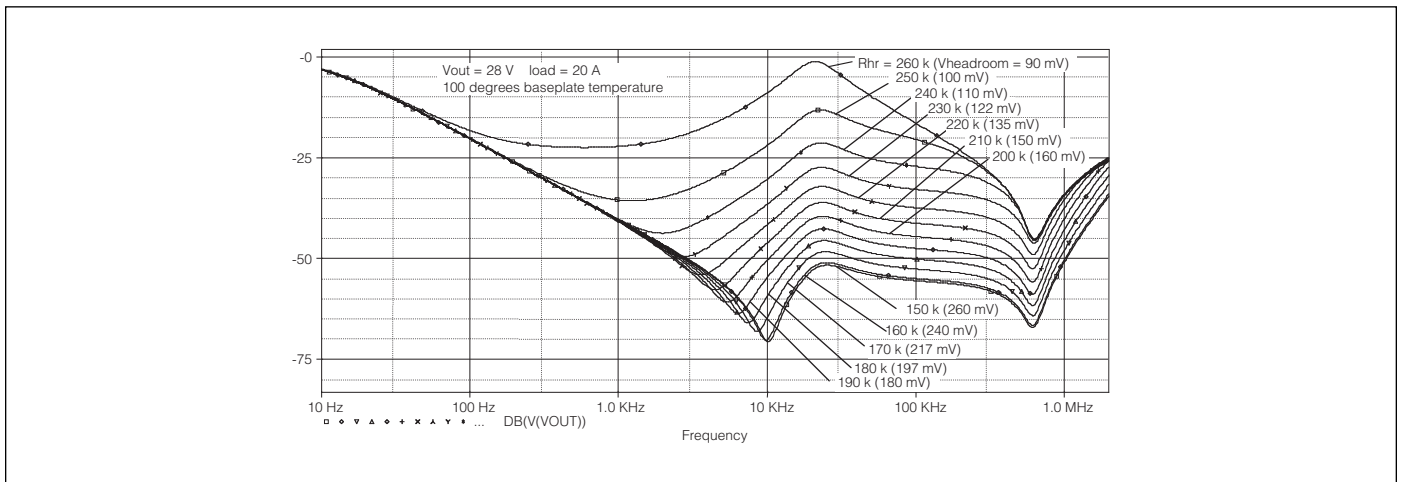

Figure 12-4b — Graph of simulated results demonstrating the tradeoff of attenuation vs. headroom setting at 20 A and a equivalent 100°C baseplate temperature at 28 V.

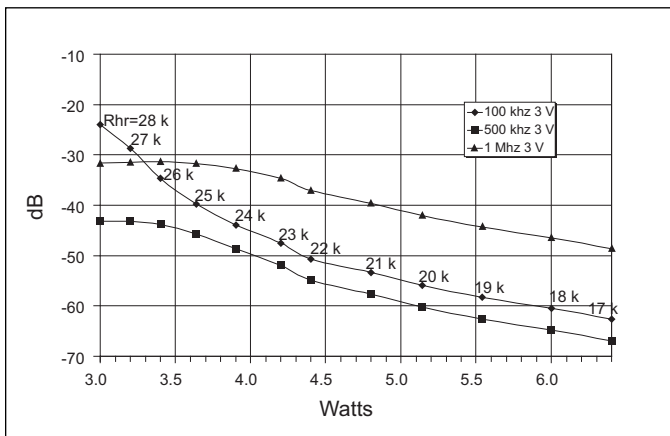

Figure 12-4c — MicroRAM attenuation vs. power dissipation at 3 V, 20 A

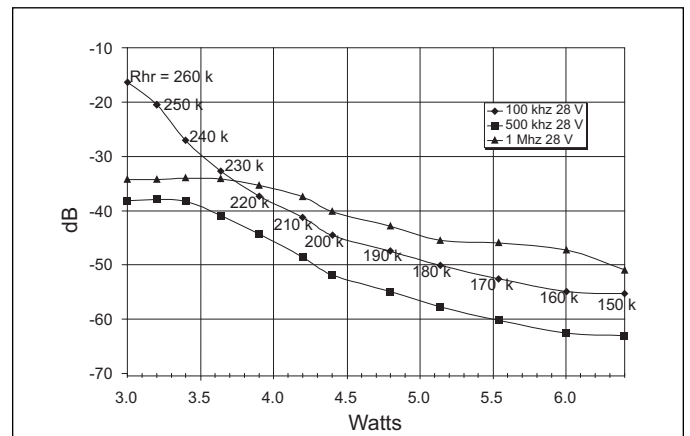

Figure 12-4d — MicroRAM attenuation vs. power dissipation at 28 V, 20 A

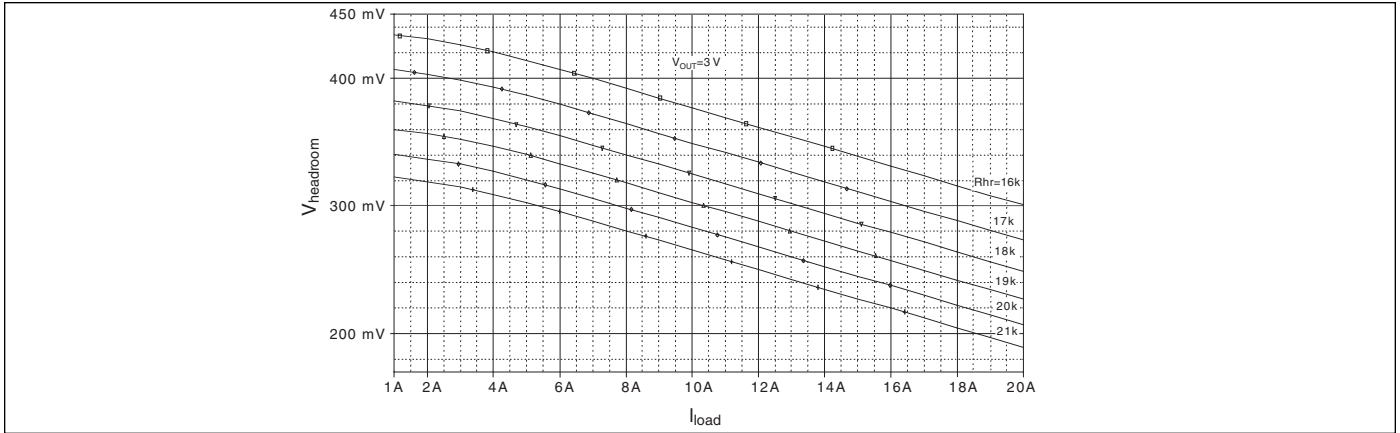

Figure 12-5 — Headroom vs. load current at 3 V output

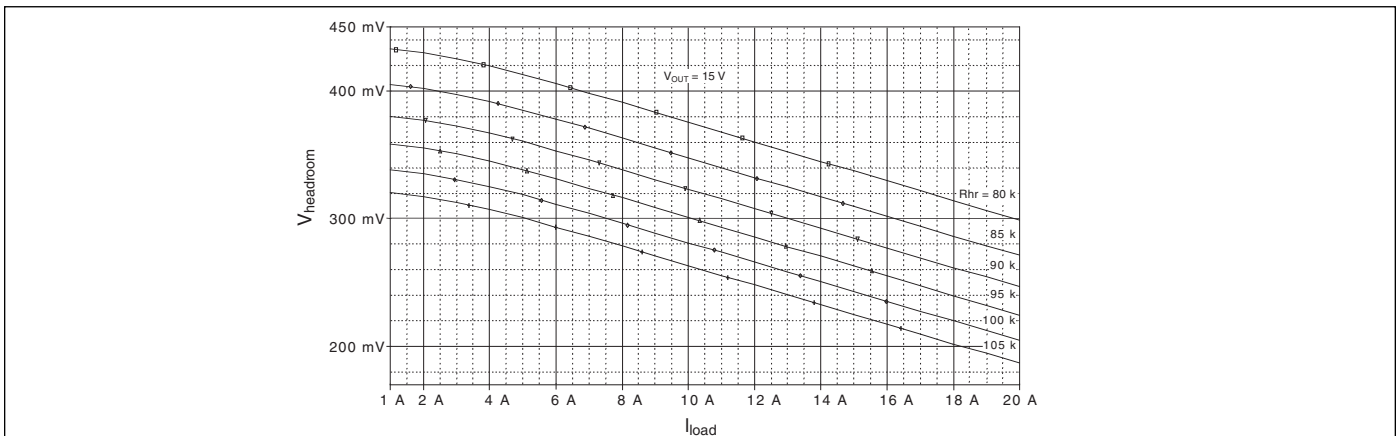

Figure 12-6 — Headroom vs. load current at 15 V output

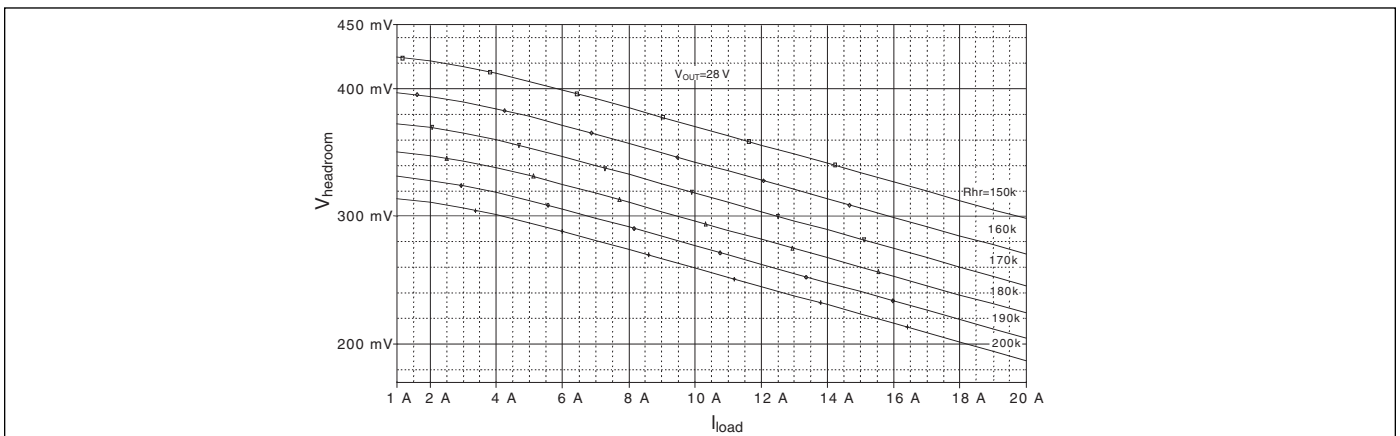
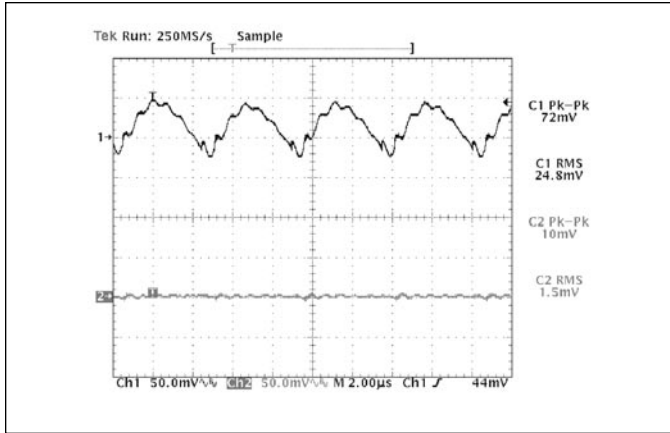
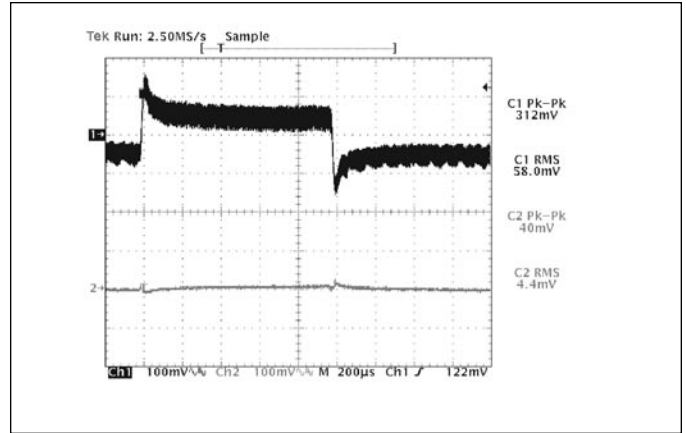

Figure 12-7 — Headroom vs. load current at 28 V output



**Figure 12-8** — V375A28C600B and  $\mu$ RAM: Input and output ripple @ 50% (10 A) load CH1 =  $V_i$ ; CH2 =  $V_o$ ;  $V_i - V_o = 332$  mV;  $R_{HR} = 178$  k



**Figure 12-9** — V375A28C600B and  $\mu$ RAM; Input and output dynamic response no added  $C_{TRAN}$ ; 20% of 20 A rating load step of 4 A (10 A – 14 A);  $R_{HR} = 178$  k (Configured as in Figures 14-1a and 14-1b)

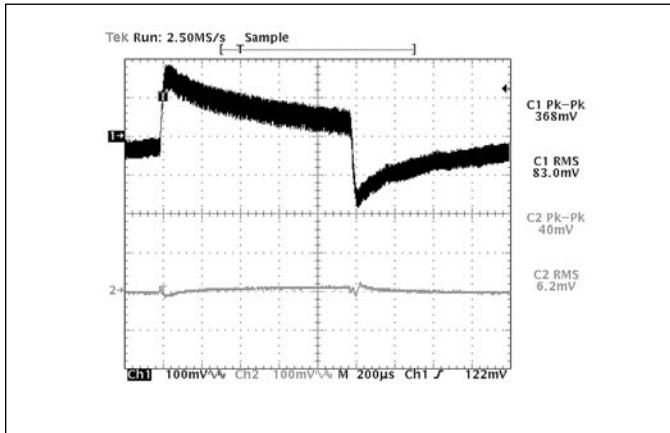

**Figure 12-10** — V375A28C600B and  $\mu$ RAM; Input and output dynamic response  $C_{TRAN} = 820$   $\mu$ F Electrolytic; 33% of load step of 6.5 A (10 A – 16.5 A);  $R_{HR} = 178$  k (Configured as in Figures 14-1a and 14-1b)

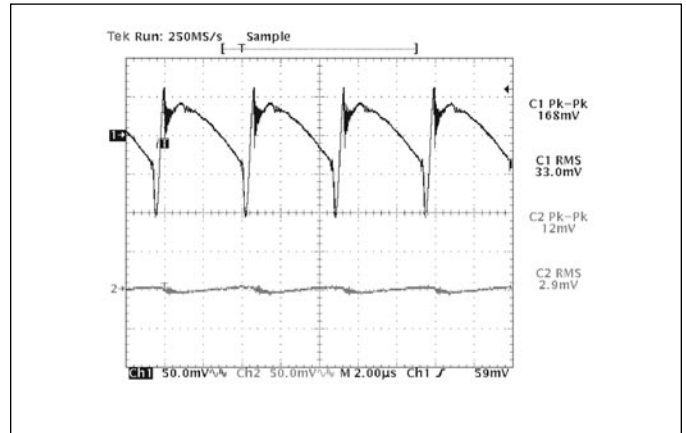

**Figure 12-11** — V375B12C250B and  $\mu$ RAM; Input and output ripple @50% (10 A) load CH1 =  $V_i$ ; CH2 =  $V_o$ ;  $V_i - V_o = 305$  mV;  $R_{HR} = 80$  k (Configured as in Figures 14-1a and 14-1b)

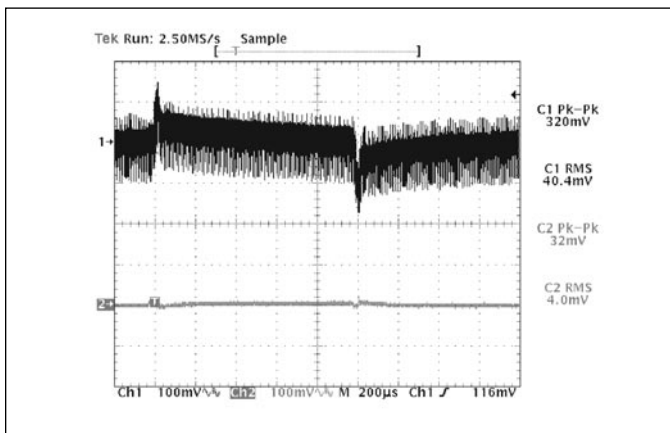

**Figure 12-12** — V300B12C250B and  $\mu$ RAM; Input and output dynamic response no added  $C_{TRAN}$ ; 18% of 20 A rating load step of 3.5 A (10 A – 13.5 A);  $R_{HR} = 80$  k (Configured as in Figures 14-1a and 14-1b)

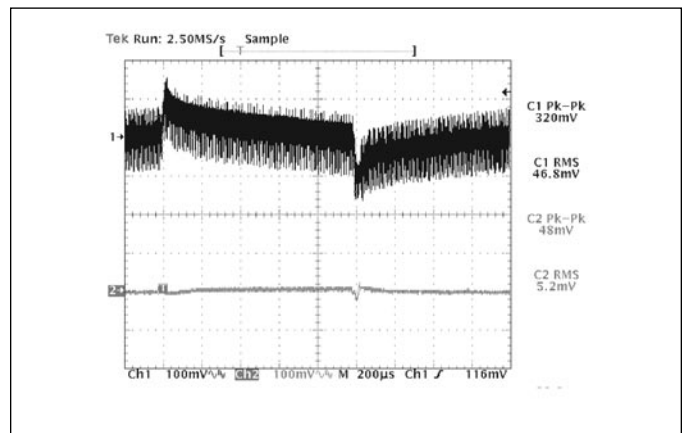

**Figure 12-13** — V300B12C250B and  $\mu$ RAM; Input and output dynamic response  $C_{TRAN} = 820$   $\mu$ F Electrolytic; 30% of load step of 6 A (10 A – 16 A);  $R_{HR} = 80$  k (Configured as in Figures 14-1a and 14-1b)

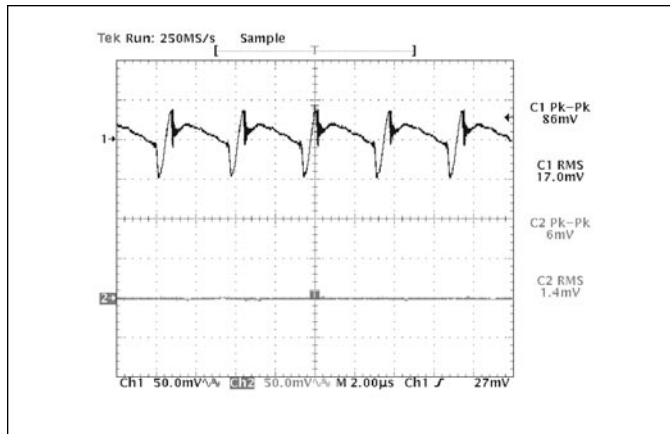

**Figure 12-14** — V48C5C100B and  $\mu$ RAM; Input and output ripple @ 50% (10 A) load CH1 =  $V_i$ ; CH2 =  $V_o$ ;  $V_i - V_o = 327$  mV;  $R_{HR} = 31$  k (Configured as in Figures 12-1a and 12-1b)

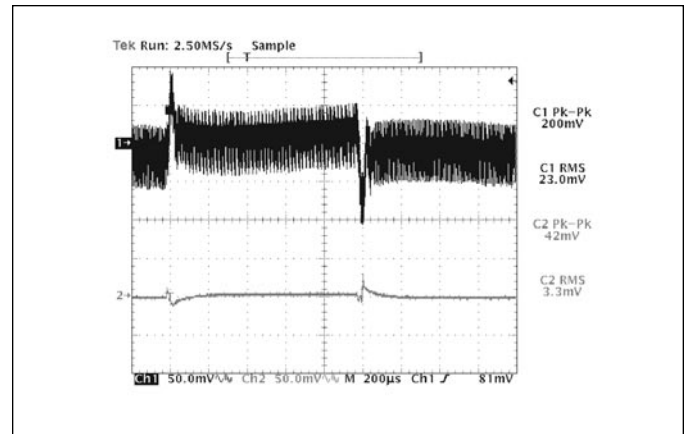

**Figure 12-15** — V48C5C100B and  $\mu$ RAM; Input and output dynamic response no added  $C_{TRAN}$ ; 23% of 20 A rating load step of 4.5 A (10 A – 14.5 A);  $R_{HR} = 31$  k (Configured as in Figures 12-1a and 12-1b)

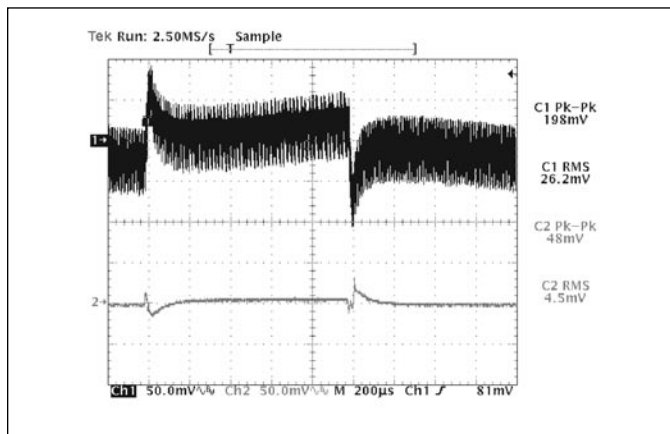

**Figure 12-16** — V48C5C100B and  $\mu$ RAM; Input and output dynamic response  $C_{TRAN} = 820$   $\mu$ F Electrolytic; 35% of load step of 7 A (10 A – 17 A);  $R_{HR} = 31$  k (Configured as in Figures 12-1a and 12-1b)

**NOTES:** The measurements in Figures 12-8 through 12-16 were taken with a  $\mu$ RAM2C21 and standard scope probes set at 20 MHz bandwidth scope setting.

The criteria for transient current capability was as follows: The transient load current step was incremented from 10 A to the peak value indicated, then stepped back to 10 A until the resulting output peak to peak measured ~ 40 mV.

## OVERVIEW

The following chapters contain soldering information for the following Vicor product families; Maxi, Mini, Micro; VE-200, VE-J00; VI BRICK, and similar package filters and front-ends. This document is intended to provide guidance for making high-quality solder connections of RoHS-compliant Vicor power modules to printed circuit boards. This application note applies to lead-free soldering of Vicor's RoHS-compliant modules. The following provides an outline for appropriate soldering procedures and the evaluation of solder joints to ensure an optimal connection to the power module. Common soldering defects will be examined and direction will be provided for detecting and handling them. Vicor's manufacturing facilities use the IPC-A-610 standards for establishing quality solder joints. It is recommended that manufacturing processes using Vicor modules refer to these same standards, which can be found, along with supporting documentation, at [www.ipc.org](http://www.ipc.org).

## ANALYSIS OF A GOOD SOLDER JOINT

The IPC-A-610 standard requires that solder fill at least 75% of the barrel to ensure a solid connection. Ideally, all connections should have a 100% fill. To accomplish this, the solder applied to both the barrel and the pin must exhibit a process known as wetting. Wetting occurs when liquid solder on a surface is heated to the point that it loses a significant amount of latent surface tension and evenly coats the surface via capillary action (both cohesion and adhesion).

During the soldering process wetting can be identified by an even coating of solder on the barrel and pin. In addition, coating the surface of barrel and pin, the solder will gather at the intersection of the two and produce a trailing fillet along each surface. Once wetting has occurred, then upon solidification it will bond appropriately to both components, producing a quality connection.

Figure 13–1 shows a side profile of a good solder joint with a power module. Notice that the solder forms a concave meniscus between pin and barrel. This is an example of a properly formed fillet and is evidence of good wetting during the soldering process. The joint between solder and pin as well as solder and pad should always exhibit a feathered edge. In Figure 13–1 it can also be seen that the solder covers a good deal of the surface area of both the pin and the pad. This is also evidence of good wetting. (Notice also that the solder joint is dull compared to leaded processing). This is evidence of good immobilization of the joint during cooling as well as good cleaning of the board prior to soldering. All soldering connections should exhibit similar characteristics regardless of

whether they are soldered by hand, by fountain, or by wave.

In examining a solder joint, be sure that there is no solder connecting one pad to another. This is known as a solder bridge and will be discussed later.

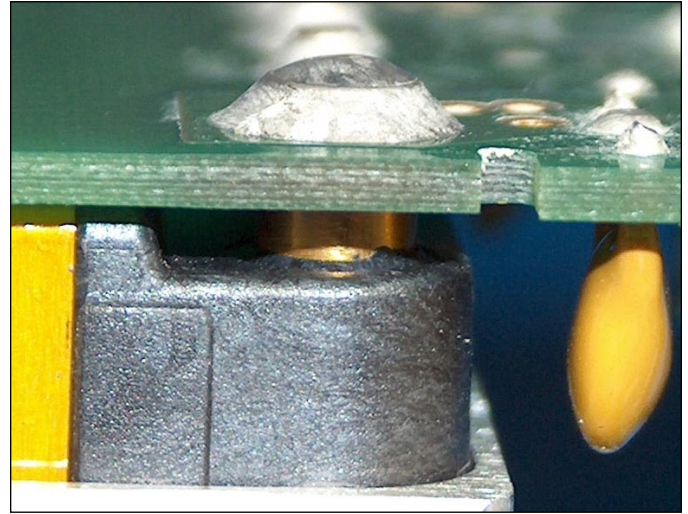

Figure 13–1 — Side profile of Maxi or Mini module's RoHS solder joint.

## SOLDERING PROCEDURES

**Hand Soldering.** Before soldering, make sure that the PCB is clean and free of debris, chemical residue, or liquid. It is not recommended that additional flux other than what is contained in the solder be used during soldering because it potentially leaves a residue that cannot be removed without potentially damaging or compromising the power module. Also, the presence of these residues on the modules may cause harm or improper operation.

The pins on Vicor modules are optimized to provide a low-resistance electrical connection. The final mounting scheme for any module should be designed to minimize any potential mechanical stress on the pins and solder joints. Modules with heat sinks or modules used in systems that are subject to shock or vibration should use standoffs to minimize stress on the pins. It is not recommended that discrete wires or connectors be soldered directly onto a module.

Also necessary for a good solder connection is pin protrusion from the PCB. It is not possible to create a good solder joint without some protrusion of module pins from the PCB. If the PCB is too thick to allow good pin protrusion, consider using Vicor module accessories such as sockets to allow proper mounting. Before soldering, the module should be mechanically affixed or immobilized with

respect to the PCB to ensure no movement during the soldering process. The standoffs can be used for this process. Vicor power modules contain two types of pins: power pins (which deliver the power to the load and are typically sized according to the rated output current) and signal pins (which typically carry very little current and are of a uniform size across a given product family). The larger the pin, the more soldering time required to form an adequate connection. In addition to the sizing of the pin, the time required to create a robust connection will vary depending on several parameters:

1. **PCB Thickness.** The thicker the printed circuit board, the more heat it is able to dissipate, and will require more soldering time.
  2. **Copper Trace Area.** Power pins require large copper traces to minimize resistive power losses in carrying the power to the load. Since the copper tends to conduct heat well, the actual sizes of these copper traces directly affect the amount of time necessary to heat the PCB socket.
  3. **Copper Trace Thickness.** As above, the thickness of the copper trace is a function of output current of the module, and has a direct impact on the amount of soldering time. Typically, PCB copper thickness is specified in terms of weight per square foot, typically 2 oz. or 3 oz. copper for current-carrying planes.
  4. **Soldering Iron Power.** A higher power soldering iron can source more heat and thus take less time to heat a PCB trace. As a soldering iron is heating a point on the board, everything that is adjacent to this point is being heated as well, including the Vicor power module. A large copper trace, because it conducts heat very well, will exhibit less of a thermal gradient, and thus a low-power soldering iron will have to heat the whole trace to a higher temperature before the area close to the iron is hot enough to flow solder. Because the trace and board are both dissipating and conducting thermal energy, some irons may not have enough power to heat a trace to the temperature that will allow proper soldering.
  5. **Tip Temperature.** Typical SAC-type solder melts at 419 – 491°F (215 – 225°C). Pb-free soldering requires a tip temperature of about 800°F. A higher tip temperature will bring the barrel and pin above the melting point of solder faster. However, a higher tip temperature may cause damage to the pad, printed circuit board, or module pin.
  6. **Type of Lead-free Solder.** The actual melting point of the solder varies depending on the type of solder used and affects the necessary temperature of the pad and pin for flow. Vicor recommends SAC305 SnAgCu solder for use on Vicor power modules.
  7. **Tip Size.** A larger tip will be able to heat a larger surface area, thus lowering soldering time.
- Since there are so many factors that influence soldering time, listing actual times is difficult. In general, it is recommended that the joint be examined post-process to insure a quality soldering joint. If necessary, different parameters can then be varied in order to ensure a solid process. The soldering times listed in Table 13–1 can be used as a guideline for establishing more application and process specific parameters. Below are some recommendations for general practice:
1. Do **not** run tip temperature above 810°F (430°C). This will greatly increase the risk of damaging the pads, traces, printed circuit board, or Vicor power module. Check with the printed circuit board manufacturer that the boards are RoHS capable and for any additional recommendations in regard to temperature.
  2. Apply the soldering iron to one side of the pin and pad and apply the solder to the other, allowing the heat from the pin and pad to melt the solder. Do **not** apply solder to the soldering iron and subsequently attempt to transfer it to the pad and pin. Melting the solder by applying it directly to the soldering iron does not guarantee adequate wetting on the joint and is not considered good technique.
  3. Do **not** apply excessive pressure with the soldering iron to the printed circuit board, barrel, or pad. This could result in breaking a trace, dislodging a barrel, or damaging the PCB, which becomes noticeably softer when heated.
  4. Do **not** apply the soldering iron to a connection for an extended period of time or damage to the module could result. If the soldering times exceed the upper limit listed in Table 13–1, consider using a larger tip or a higher power soldering iron.
  5. Make sure PCB pads and holes are clean before to soldering.
  6. Solders with no-clean flux may be used to facilitate soldering.
  7. Keep the tip of the soldering iron clean and free from resin. Apply a small amount of solder directly to the tip of the iron. This process is known as tinning.

8. Be careful not to jar the module or PCB while the solder is cooling. This could result in a cold solder joint, a void in the barrel, or a cracked joint.
9. If it is necessary to re-solder a joint, remove all existing solder from the pad and pin before reapplying solder.
10. Use of a soldering gun is **not** recommended for soldering Vicor modules.
11. It is **not** recommended that Maxi / Mini / Micro module pins be trimmed under any circumstances.

As a procedural benchmark, given an 800°F (427°C) temperature on a 60 W iron with a 3 mm tip, approximate times to solder a Vicor power module to a 0.062 (1,5 mm) thick PCB board with an appropriately sized copper trace would be in the range of Table 13–1.

Converter Family	Pin Type	Soldering Time (range)
VE-200 / VE-J00	Signal	3 – 5 seconds
VE-200	Power	5 – 8 seconds
VE-J00	Power	4 – 7 seconds
Maxi/ Mini/ Micro	Signal	3 – 5 seconds
Maxi	Power	5 – 8 seconds
Mini	Power	4 – 7 seconds
Micro	Power	3 – 5 seconds
VI BRICK	Input & Signal	3 – 5 seconds
VI BRICK	Power	4 – 7 seconds

Also relevant for similar packaged accessory modules

**Table 13–1** — Recommended pin soldering times for RoHS family modules

Again, please note that soldering for significantly longer periods of time than those listed above could result in damage to the module. Table 13–1 should not be used without verifying that the times will produce a quality soldering joint as defined in the previous sections.

**Wave Soldering.** Vicor modules achieve an adequate solder connection on a wave-soldering machine with conveyor speeds from three to seven feet per minute. As with hand soldering, times and parameters vary with the properties of the PCB and copper traces. As a standard benchmark, the parameters below may be used. As with hand-soldered boards, the results should be examined to ensure a quality soldering joint and a sound process.

**Wave Soldering Profile.**

1. Bottom-side preheaters: Zone 1: 350°F (177°C), Zone 2: 300°F (149°C), Zone 3: 675°F (357°C)
2. Top-side preheaters: 220 – 235°F (104 – 113°C)
3. Wave temperature: 510°F (266°C)
4. Wave type: 4.25 in (107,95 mm) standard laminar wave

Preheating of the PCB is generally required for wave soldering operations to ensure adequate wetting of the solder to the PCB. The recommended temperature for PCB topside is 203 – 248°F (95 – 120°C) prior to the molten wave. Thick, multilayer PCBs should be heated toward the upper limit of this range, while simple two-layer PCBs should be heated to the lower limit. These parameters are consistent with generally accepted requirements for circuit-card assembly. The power module is often much more massive than other components mounted to the PCB. During wave solder preheating, the pins will dissipate much of their absorbed heat within the module; therefore, adjustments to preheaters alone will not improve module soldering significantly. A more effective way to improve the soldering of the module is to lower the conveyor speed and increase the dwell time in the molten wave. Approximately 5 seconds of exposure to the molten wave is required to achieve an acceptable solder joint for a Maxi / Mini / Micro power module. The VE-200 / VE-J00/ VE-HAM and VI BRICK modules should solder in approximately 4 seconds of molten wave exposure.

**Post Solder Cleaning.** Vicor modules are not hermetically sealed and must not be exposed to liquid, including but not limited to cleaning solvents, aqueous washing solutions or pressurized sprays. Cleaning the backside of the PCB is acceptable provided no solvent contacts the body of the module.

When soldering, it is recommended that no-clean flux solder be used, as this will ensure that potentially corrosive mobile ions will not remain on, around, or under the module following the soldering process.

If the application requires the PCB to be subject to an aqueous wash after soldering, then it is recommended that Vicor module accessories such as through-hole or surface-mount sockets be used. These sockets should be mounted to the PCB, and the modules subsequently inserted following the aqueous washing sequence.

**De-soldering Vicor Modules.** Vicor modules should not be re-used after desoldering for the following reasons:

1. Most de-soldering procedures introduce damaging mechanical and thermal stresses to the module.
2. Devices or processes that may be capable of desoldering a Vicor module from a printed-circuit board without causing damage have not been qualified for use with Vicor modules.

For applications that require removal of a module with the intent of reuse, use Vicor socketing systems.

### Index of Common Soldering defects.

1. **Solder Bridge.** A short circuit between two electrically inadvertently forming a “bridge” or connection between the two points.

**Recommended Solution.** Use a smaller soldering tip, or hold the tip at a different angle when soldering, so as to contact only one pad at a time.

2. **Cold Solder.** An incomplete or poor connection caused by either the barrel or the pin not being heated to the flow temperature of solder. A cold solder joint will typically exhibit a convex meniscus with possibly a dark spot around the barrel or pad. Also, a cold solder joint will not be shiny, but will typically have a “dirty” appearance.

**CAUTION:** A cold solder joint is not necessarily an open connection electrically, and cannot be diagnosed by a simple continuity check. A cold solder joint is frequently an electrically intermittent connection and is best diagnosed by way of visual inspection. A cold solder joint will likely become electrically open following a period of temperature cycling.

**Recommended Solution.** Increase soldering iron temperature, soldering time, or use a soldering iron with a higher output wattage if hand soldering. If wave soldering, lower conveyor speed or increase preheat temperature.

3. **PC Board Damage.** An intermittent or poor connection caused by damage to a trace, pad, or barrel. A damaged pad is best identified by a burn mark on the PCB, or a trace pad that moves when prodded with a mechanical object.

**Recommended Solution.** Lower the soldering iron temperature or the soldering time. If damage persists, use a lower power iron, or consult with the manufacturer of the PCB for recommended soldering guidelines.

4. **De-wetting.** The solder initially appears to wet but then pulls back to expose the pad surface. More common in wave-soldering.

**Recommended Solution.** Make sure the PCB is clean prior to soldering.

5. **Dry Joint.** The solder has a dull gray appearance as opposed to a bright silver surface. The solder joint may have a mottled look as well, with jagged ridges. It is caused by the solder joint moving before it has completely cooled.

**Recommended Solution.** Immobilize the module with respect to the PCB to ensure that the solder joint cools properly.

6. **Icicles.** Jagged or conical extensions from solder fillet. These are caused by soldering with the temperature too low, or soldering to a highly heat absorbent surface.

**Recommended Solution.** Increase the soldering temperature, but not outside the recommended limits. If necessary, use a higher power soldering iron.

7. **Pinholes.** Small or large holes in surface of solder joint, most commonly occurring in wave solder systems.

**Recommended Solution.** Increase preheat or topside heater temperature, but not outside the recommended limits.

References	
<p><u>Organizations</u>  <a href="http://www.ipc.org">www.ipc.org</a></p> <p><u>Commercial</u>  <a href="http://www.aimsolder.com">www.aimsolder.com</a>  <a href="http://www.alphametals.com">www.alphametals.com</a>  <a href="http://www.kester.com">www.kester.com</a>  <a href="http://www.multicore.com">www.multicore.com</a></p>	

Maxi / Mini / Micro Standoff Kits for Solder Mounted Modules							
Board Thickness	Mounting Options		Slotted Baseplate		Through-Hole Baseplate		Threaded Baseplate
	Mounting Style	Pin Style	Through-Hole Heat Sink	Threaded Heat Sink	Through-Hole Heat Sink	Threaded Heat Sink	Through-Hole Heat Sink
0.062" (0.055"/0.071") 1,5 mm (1,4 mm / 1,8 mm)	In-Board	F	Kit-18150 Bag-19126	Kit-18151 Bag-19127	Kit-18146 Bag-19122	Kit-18147 Bag-19123	Kit-18146 Bag-19122
	On-Board	G	Kit-18156 Bag-19132	Kit-18157 Bag-19133	Kit-18150 Bag-19126	Kit-18152 Bag-19128	Kit-18150 Bag-19126
0.093" (0.084"/0.104") 2,4 mm (2,1 mm / 2,6 mm)	In-Board	G	Kit-18150	Kit-18151	Kit-18146	Kit-18147	Kit-18146
			Bag-19126	Bag-19127	Bag-19122	Bag-19123	Bag-19122

**Table 13-2** — Standoff Kits for solder mounted modules

Kits include six (6) standoffs and screws. Mini and Micro modules require a minimum of four (4) standoffs. Bags contain 100 standoffs only (#4-40 screws required).

VI BRICK Standoff Kits		
Standoffs	Description	Part No.
F-F Standoff 0.287" long	12 pc Kit for 0.125" PCB (includes M3 x 5 mm and M3 x 6 mm screws)	34717
	12 pc Kit for 0.062" PCB (includes M3 x 5 mm screws)	34718
	100 pc bag	34709
M-F Standoff 0.287" long	12 pc Kit (includes M3 x 6 mm screws)	34719
	100 pc bag	34710

Bags contain 100 standoffs only (M3 screws required).

### OVERVIEW

The following chapters contain soldering information for the following Vicor product families; Maxi, Mini, Micro; VI-200, VI-J00; VI BRICK, and similar package filters and front-ends. This document is intended to provide guidance in utilizing soldering practices to make high-quality connections of Vicor power modules to printed circuit boards. Some care will be taken to outline appropriate soldering procedures as well as the evaluation of solder joints in a manner that enables the customer to ensure that the end application has an optimal connection to the power module. Common soldering defects will be examined and direction will be provided for detecting and handling the common defects.

Vicor's manufacturing facilities use the IPC-A-610C standards as a means of establishing quality solder joints. It is recommended that manufacturing processes using Vicor modules refer to these same standards, which can be found, along with supporting documentation, at [www.ipc.org](http://www.ipc.org).

### ANALYSIS OF A GOOD SOLDER JOINT

The IPC-A-610C standard requires that solder fill at least 75% of the barrel in order to ensure a solid connection. Ideally, all connections should have a 100% fill. In order to accomplish this, the solder applied to both the barrel and the pin must exhibit a process known as wetting. Wetting occurs when liquid solder on a surface is heated to the point that it loses a significant amount of latent surface tension and evenly coats the surface via capillary action (both cohesion and adhesion).

During the soldering process wetting can be identified by an even coating of solder on the barrel and pin. In addition to coating the surface of barrel and pin, the solder will gather at the intersection of the two and produce a trailing fillet along each surface. Once wetting has occurred, then upon solidification it will bond appropriately to both components, producing a quality connection. Figure 14-1 shows a side profile of a good solder joint with a Mini power module. Notice that for both examples the solder forms a concave meniscus between pin and barrel. This is an example of a properly formed fillet and is evidence of good wetting during the soldering process. The joint between solder and pin as well as solder and pad should always exhibit a feathered edge. In Figure 14-1 it can also be seen that the solder covers a good deal of the surface area of both the pin and the pad. This is also evidence of good wetting. Notice also that the solder joint has a smooth surface with a silver color. This is evidence of good immobilization of the joint during cooling as well as good cleaning of the board prior to soldering. All soldering connections should exhibit

similar characteristics regardless of whether they are soldered by hand or wave soldered.

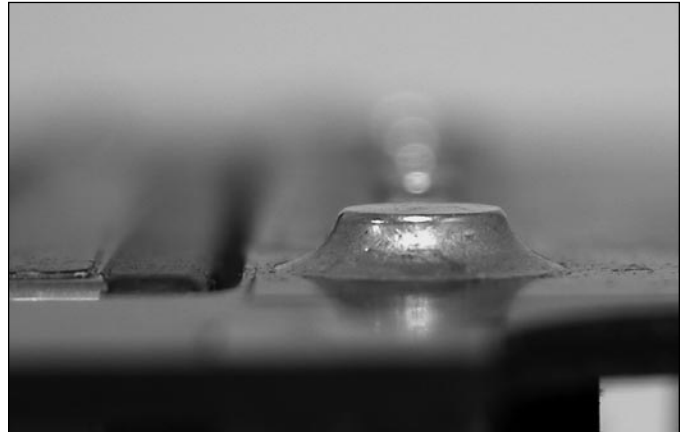

**Figure 14-1** — Side profile of a Mini module solder joint

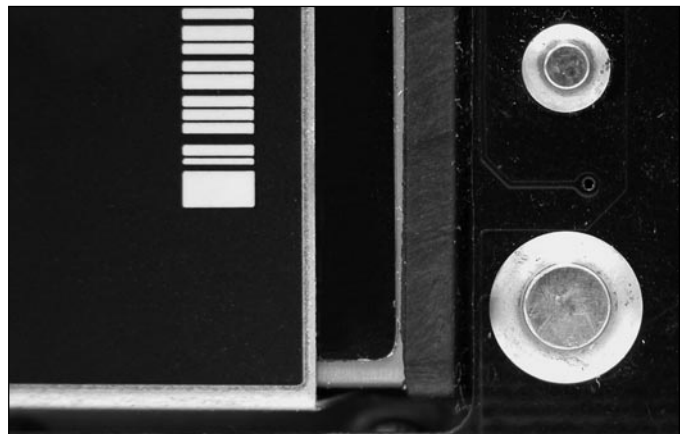

**Figure 14-2** — Maxi / Mini output power pin and Sense pin

Figure 14-2 is a top view of the signal and power pin of a Maxi or Mini module properly soldered to a printed circuit board. Notice that both the joint and the area around the joint are clean and free from resin and solder residue. Also the pad and printed circuit board adjacent to the barrel are not burnt or discolored and are solidly attached to each other. In examining a solder joint, be sure that there is no solder connecting one pad to another. This is known as a solder bridge and will be discussed further along with other potential soldering defects.

### SOLDERING PROCEDURES

**Hand Soldering.** Before soldering, make sure that the PCB is clean and free of debris, chemical residue, or liquid. It is not recommended that additional flux other than what is contained in the solder be used during soldering as it potentially leaves a residue that cannot be removed without potentially damaging or compromising the power module. Also, the presence of these residues themselves on the modules may cause harm or improper operation. The pins on Vicor modules are optimized in design for providing a low-resistance electrical connection. The final mounting scheme for any module should be designed so as to minimize any potential mechanical stress on the pins and solder joints. Modules with heat sinks or modules used in systems that are subject to shock or vibration should use standoffs to minimize stress on the pins. Tin / lead pins are specifically designed for soldering applications while gold pin options are specified for socketed applications (see SurfMate or InMate mounting systems). It is not recommended that discrete wires or connectors be soldered directly onto a module.

Also necessary for a good solder connection is pin protrusion from the PCB. It is not possible to create a good solder joint without some protrusion of module pins from the PCB. If the PCB is too thick to allow good pin protrusion, consider using Vicor module accessories such as sockets to allow proper mounting.

Before soldering, the module should be mechanically affixed or immobilized with respect to the PCB to ensure no movement during the soldering process. The standoffs can be used for this process.

Vicor power modules contain two types of pins: power pins (which deliver the power to the load and are typically sized according to the rated output current) and signal pins (which typically carry very little current and are of a uniform size across a given product family). The larger the pin, the more soldering time required to form an adequate connection. In addition to the sizing of the pin the time required to create a robust connection will vary depending on several parameters:

1. **PCB Thickness.** The thicker the printed circuit board is, the more heat it is able to dissipate, and thus it will require more soldering time.
2. **Copper Trace Area.** Power pins require large copper traces to minimize resistive power losses in carrying the power to the load. Since the copper tends to conduct heat rather well, the actual size of these copper traces directly affect the amount of time necessary to heat the PCB socket.
3. **Copper Trace Thickness.** As above, the thickness of the copper trace is a function of output current of the module, and has a direct impact on the amount of soldering time. Typically, PCB copper thickness is specified in terms of weight per square foot, typically 2 oz. or 3 oz. copper for current-carrying planes.
4. **Soldering Iron Power.** A higher power soldering iron can source more heat and thus take less time to heat a PCB trace. When a soldering iron is heating a point on the board, everything that is adjacent to this point is being heated as well, including the Vicor power module. A large copper trace, because it conducts heat very well, will exhibit less of a thermal gradient and thus a low-power soldering iron will have to heat the whole trace to a higher temperature before the area close to the iron is hot enough to flow solder. Because the trace and board are both dissipating and conducting thermal energy, some irons may not have enough power to heat a trace to the temperature that will allow proper soldering.
5. **Tip Temperature.** Typical 63 / 37 solder melts at 392°F (200°C). A higher tip temperature will bring the barrel and pin above the melting point of solder faster. However, a higher tip temperature may cause damage to the pad, printed circuit board, or module pin.
6. **Type of Solder.** The actual melting point of the solder varies depending on the type of solder used and affects the necessary temperature of the pad and pin for flow. Vicor recommends 63 / 37 SnPb solder for use on Vicor power modules.
7. **Tip Size.** A larger tip will be able to heat a larger surface area, thus lowering soldering time.

Since there are so many factors that influence soldering time, listing actual times is difficult. In general, it is recommended that the joint be examined post-process to ensure a quality soldering joint. If necessary, different parameters can then be varied in order to ensure a solid process. The soldering times listed in Table 14–1 can be used as a guideline for establishing more application and process-specific parameters. Below are some recommendations for general practice:

1. Do not run tip temperature above 750°F (400°C) because it will greatly increase the risk of damaging the pads, traces, printed circuit board, or Vicor power module. Check with the printed circuit board manufacturer for any additional recommendations with regards to temperature.
2. Apply the soldering iron to one side of the pin and pad and apply the solder to the other, allowing the heat from the pin and pad to melt the solder. Do not apply solder to the soldering iron and subsequently attempt to transfer it to the pad and pin. Melting the solder by applying it directly to the soldering iron does not guarantee adequate wetting on the joint and is not considered good technique.
3. Do not apply excessive pressure with the soldering iron to the printed circuit board, barrel, or pad. This could result in breaking a trace, dislodging a barrel or damaging the PCB, which becomes noticeably softer when heated.
4. Do not apply the soldering iron to a connection for an extended period of time or damage to the module could result. If the soldering times exceed the upper limit listed in Table 14–1, consider using a larger tip or a higher power soldering iron.
5. Make sure PCB pads and holes are clean prior to soldering.
6. Solders with no-clean flux may be used to facilitate soldering.
7. Keep the tip of the soldering iron clean and free from resin. Apply a small amount of solder directly to the tip of the iron. This process is known as tinning.
8. Be careful not to jar the module or PCB while the solder is cooling. This could result in a cold solder joint, a void in the barrel, or a cracked joint.
9. If it is necessary to re-solder a joint, remove all existing solder from the pad and pin prior to reapplying solder.
10. Use of a soldering gun is **not** recommended for soldering Vicor modules.

11. It is **not** recommended that Maxi, Mini, Micro module pins be trimmed under any circumstances.
12. The caps of the InMate socket are designed to repel solder. It is normal for this surface to be free of solder.

As a procedural benchmark, given a 750°F (400°C) temperature on a 60 W iron with a 0.19 in (3 mm) tip, approximate times to solder a Vicor power module to a 0.062 (1,5 mm) thick PCB board with an appropriately sized copper trace would be in the range of Table 14–1.

Converter Family	Pin Type	Soldering Time (range)
VI-200 / VI-J00	Signal	3 – 5 seconds
VI-200	Power	5 – 8 seconds
VI-J00	Power	4 – 7 seconds
Maxi/ Mini/ Micro	Signal	3 – 5 seconds
Maxi	Power	5 – 8 seconds
Mini	Power	4 – 7 seconds
Micro	Power	3 – 5 seconds

**Table 14–1** — Recommended pin soldering times for Vicor modules

Again, please note that soldering for significantly longer periods of time than the time listed above could result in damage to the module. The time listed in Table 14–1 should not be used without verifying that the times will produce a quality soldering joint as defined in the previous sections.

**Wave Soldering.** Vicor modules achieve an adequate solder connection on a wave soldering machine with conveyor speeds from three to seven feet per minute. As with hand soldering, times and parameters vary with the properties of the PCB and copper traces. As a standard benchmark the parameters below may be used. As with hand-soldered boards, the results should be examined to ensure a quality soldering joint and a sound process.

**Wave Soldering Profile.**

1. Bottom-side preheaters: Zone 1: 650°F (343°C), Zone 2: 750°F (398°C)
2. Top-side preheaters: 203 – 248°F (95 – 120°C)
3. Wave temperature: 500°F (260°C)
4. Wave type: 4.25 in (107,9 mm) standard laminar wave

Preheating of the PCB is generally required for wave soldering operations to ensure adequate wetting of the solder to the PCB. The recommended temperature for PCB topside is 203 – 248°F (95 – 120°C) prior to the molten wave. Thick, multilayer PCBs should be heated toward the upper limit of this range, while simple two-layer PCBs should be heated to the lower limit. These parameters are consistent with generally accepted requirements for circuit-card assembly.

The power module is often much more massive than other components mounted to the PCB. During wave solder preheating, the pins will dissipate much of their absorbed heat within the module. Adjustments to pre-heaters alone, therefore, will not improve module soldering significantly.

A more effective way to improve the soldering of the module is to lower the conveyor speed and increase the dwell time in the molten wave. Approximately 5 seconds of exposure to the molten wave is required to achieve an acceptable solder joint for a Maxi, Mini, or Micro power module.

**Post Solder Cleaning.** Vicor modules are not hermetically sealed and must not be exposed to liquid, including but not limited to cleaning solvents, aqueous washing solutions, or pressurized sprays. Cleaning the backside of the PCB is acceptable provided no solvent contacts the body of the module.

When soldering, it is recommended that no-clean flux solder be used, as this will ensure that potentially corrosive mobile ions will not remain on, around, or under the module following the soldering process.

If the application requires the PCB to be subject to an aqueous wash after soldering, then it is recommended that Vicor module accessories such as through-hole or surface-mount sockets be used. These sockets should be mounted to the PCB and the modules subsequently inserted following the aqueous washing sequence.

**De-soldering Vicor Modules.** Vicor modules should not be re-used after desoldering for the following reasons:

1. Most de-soldering procedures introduce damaging mechanical and thermal stresses to the module.
2. Devices or processes that may be capable of de-soldering a Vicor module from a printed circuit board without causing damage have not been qualified for use with Vicor modules. For applications that require removal of a module with the intent of reuse, use Vicor socketing systems.

### *Index of Common Soldering defects.*

1. **Solder Bridge.** A short circuit between two electrically unconnected points caused by a piece of solder inadvertently forming a “bridge” or connection between the two points.

**Recommended Solution.** Use a smaller soldering tip, or hold the tip at a different angle when soldering, so as to only contact one pad at a time.

2. **Cold Solder.** An incomplete or poor connection caused by either the barrel or the pin not being heated to the flow temperature of solder. A cold solder joint will typically exhibit a convex meniscus with possibly a dark spot around the barrel or pad. Also a cold solder joint will not be shiny, but will typically have a “dirty” appearance.

**CAUTION:** A cold solder joint is not necessarily an open connection electrically, and cannot be diagnosed by a simple continuity check. A cold solder joint is frequently an electrically intermittent connection and is best diagnosed by visual inspection. A cold solder joint will likely become electrically open following a period of temperature cycling.

**Recommended Solution.** Increase soldering iron temperature, soldering time, or use a soldering iron with a higher output wattage if hand soldering. If wave soldering, lower conveyor speed or increase preheat temperature.

3. **PC Board Damage.** An intermittent or poor connection caused by damage to a trace, pad, or barrel. A damaged pad is best identified by a burn mark on the PCB, or a trace of pad that moves when prodded with a mechanical object.

**Recommended Solution.** Lower the soldering iron temperature or the soldering time. If damage persists use a lower power iron, or consult with the manufacturer of the PCB for recommended soldering guidelines.

4. **De-wetting.** The solder initially appears to wet but then pulls back to expose the pad surface, more common in wave soldering.

**Recommended Solution.** Make sure the PCB is clean prior to soldering.

## 14. Recommended Soldering Methods, Tin Lead Pins, and InMate Sockets

5. **Dry Joint.** The solder has a dull gray appearance as opposed to a bright silver surface. The solder joint may have a mottled look as well, with jagged ridges. It is caused by the solder joint moving before completely cooled.

**Recommended Solution.** Immobilize the module with respect to the PCB to ensure that the solder joint cools properly.

6. **icicles.** Jagged or conical extensions from solder fillet. These are caused by soldering with the temperature too low, or soldering to a highly heat-absorbent surface.

**Recommended Solution.** Increase the soldering temperature, but not outside the recommended limits. If necessary, use a higher power soldering iron.

7. **Pinholes.** Small or large holes in surface of solder joint, most commonly occurring in wave-solder systems.

**Recommended Solution.** Increase preheat or topside heater temperature, but not outside the recommended limits.

References
<p><b>Organizations</b>  <a href="http://www.ipc.org">www.ipc.org</a></p> <p><b>Commercial</b>  <a href="http://www.aimsolder.com">www.aimsolder.com</a>  <a href="http://www.alphametals.com">www.alphametals.com</a>  <a href="http://www.kester.com">www.kester.com</a>  <a href="http://www.multicore.com">www.multicore.com</a></p>

Maxi / Mini / Micro Standoff Kits for Solder Mounted Modules*							
Board Thickness	Mounting Options		Slotted Baseplate		Through-Hole Baseplate		Threaded Baseplate
	Mounting Style	Pin Style	Through-Hole Heat Sink	Threaded Heat Sink	Through-Hole Heat Sink	Threaded Heat Sink	Through-Hole Heat Sink
0.062" (0.055" / 0.071") (1,5 mm)	In-Board	Short Tin/Lead	Kit-18150	Kit-18151	Kit-18146	Kit-18147	Kit-18146
			Bag-19126	Bag-19127	Bag-19122	Bag-19123	Bag-19122
(1,4 mm / 1,8 mm)	On-Board	L	Kit-18156	Kit-18157	Kit-18150	Kit-18152	Kit-18150
			Bag-19132	Bag-19133	Bag-19126	Bag-19128	Bag-19126
0.093" (0.084" / 0.104") 2,4 mm	In-Board	L	Kit-18150	Kit-18151	Kit-18146	Kit-18147	Kit-18146
			Bag-19126	Bag-19127	Bag-19122	Bag-19123	Bag-19122
(2,1 mm / 2,6 mm)							

**Table 14-2** — Standoff kits for solder mounted modules

\* Kits include six (6) standoffs and screws. Mini and Micro modules require a minimum of four (4) standoffs. 100 piece bags contain standoffs only (#4-40 screws required).

SurfMate is a surface-mount connector system for use with pin-compatible Maxi, Mini, Micro Family converters and input / front-end modules. For the first time, circuit-board designers and assemblers have the ability to surface mount high-density DC-DC converters having current ratings up to 50 A. (Table 15–1)

SurfMate utilizes a pair of surface-mounted headers that contain sockets to accept the input and output pins of the module. (Table 15–2) The SurfMate header assembly is compatible with any thickness PC board, does not increase the module mounting height above the board, and is available for all three standard module size: Maxi, Mini, and Micro (full, half, and quarter bricks).

SurfMates are available packaged in standard recyclable JEDEC-style trays for use with automated pick-and-place equipment and are compatible with standard reflow solder operations. After reflow, the modules are simply inserted into the SurfMates. Any secondary soldering operation used for through-hole sockets or pins can now be entirely eliminated —reducing manufacturing time and eliminating dual processes.

This unique interconnect scheme combines the inherent flexibility of component power designs with the manufacturing efficiency of surface-mount assembly.

#### PRINTED CIRCUIT BOARD DESIGN AND SOLDER GUIDELINES FOR THE SURFMATE SOCKETING SYSTEM

Recommended PCB layout drawings for SurfMates are provided in the following links. All unspecified PCB dimensional tolerances comply with ANSI/IPC-D-300 for Class “B” boards. DXF versions of the PCB outlines are available in the SurfMate section of the [Vicor mechanical drawings web page](#).

**Recommended PCB Construction.** The SurfMate system is capable of very high current-carrying capacity. We therefore recommend a multilayer PCB with 3-ounce copper and internal power and ground planes. Consult the drawings for the recommended size and quantity of via holes for carrying current to the internal planes.

**Solder Mask and Pad.** Two solder mask keep-out areas are recommended. The larger area encompasses the complete pad area at either end. It ensures the proper height of the 3-ounce solder pads to the surrounding laminate. This provides for the optimum gap between the SurfMate and the PCB  $0.0042" \pm 0.0004"$  (0,106 mm  $\pm 0,010$  mm), minimizing the solder paste thickness required for quality solder joints. Without this solder mask keep-out area, the gap may widen, (see “Flush-Mounted Pads”), requiring thicker solder paste to fill the larger gap.

The smaller solder mask keep-out areas are circular, and are located on each pad, for the solder joint between the PCB and the SurfMate. The remainder of the pad has a covering of solder mask. The solder paste is dispensed in a rectangular area covering the soldering area and part of the solder mask area. During soldering, the paste will migrate away from the solder mask area to the soldering area, providing ample volume for quality solder joints.

Each pad features a non-plated through hole in the center of the pad to provide a venting function. It is normal for the solder joint to have a slight void centered on this through hole.

**Solder Paste.** Solder paste thickness requirements will vary depending on whether the board pads are flush or elevated from the laminate.

**Elevated Pads (preferred).** The ideal height for elevated pads is  $0.0042"$  (0,106 mm)  $\pm 10\%$ . This can be achieved by using a 3-ounce copper surface layer. With this height, a minimum solder paste thickness of  $0.006"$  should be used. Thicker stencils of between  $0.008"$  (0,203 mm) and  $0.012"$  (0,305 mm) are preferred.

**Flush-Mounted Pads.** For boards with flush-mounted pads a minimum of  $0.010"$  (0,254 mm) solder paste should be used. Preferred thickness is between  $0.012"$  (0,305 mm) and  $0.016"$  (0,406 mm).

**Placement.** SurfMate locating pins will engage in the corresponding PCB holes with a light push of the SurfMate into the solder paste. The SurfMate should not be taped or adhered in place. The surface tension of the solder during reflow will center the SurfMate parts on the PCB, resulting in accurate positioning.

**Equipment and Solder.** Soldering of SurfMates should be done using either an infrared or convection oven reflow process. Solder type Sn63Pb37, or equivalent, with a eutectic temperature of  $361^\circ\text{F}$  ( $183^\circ\text{C}$ ) should be used. Higher temperature solder is **not** recommended.

**Standoffs.** Mounting standoffs are required for SurfMate applications. The location for standoff holes is shown on the PCB layout. A selection chart of recommended standoff kits is provided in this section.

**Module Pins.** SurfMates must be used with modules with the “S” or “F” pin style.

**Module Insertion / Extraction.** Sockets and modules are rated for up to 5 insertions and extractions before requiring replacement. When installing a module, lightly place it into position so that all pins are properly aligned over each socket. Then apply even pressure by uniformly tightening each of the mounting screws through the mounting slots on the baseplate into the pcb mounted standoffs. For

module removal, Vicor highly recommends the use of our Module Exchange Tool in order to ensure that the sockets are not damaged during the module removal process.

Removing the module at an angle should be avoided as this can damage the sockets.

SurfMate: Surface Mount Sockets											
		Full Brick (Maxi)			Half Brick (Mini)			Quarter Brick (Micro)			
Board Thickness	Mounting Style	Input	Output	5 Sets	Input	Output	5 Sets	Input	Output	5 Sets	Pin Style
All	Surface mount	22100	22101	16017	22100	22102	16021	22103	22104	16025	S, F

Parameter	Specification Value	Reference
<b>Compatibility</b>	F	Short RoHS pins
Module pin style	S	Short ModuMate pins
<b>Mechanical</b>		
Contact normal force	100 grams EOL min.	GR-1217-CORE, R5-23
Number of mating cycles	5 max. <sup>(Note4)</sup>	Exception to GR-1217-CORE which specifies 25 mating cycle
Module engagement force	32 lbs per connector set max.	GR-1217-CORE, R5-31,32
Module disengagement force	32 lbs per connector set max.	GR-1217-CORE, R5-31,32
<b>Electrical</b>		
Current rating	50 A Maxi <sup>(Note1)</sup> , Mini; 25 A Micro (Based on 248°F (120°C) max. socket temp. & 86°F (30°C) max temperature rise of contact)	Gold plating standards, and accepted industry standards such as IICIT, EIA, Bellcore guidelines
Low level contact resistance 0.080" (2,03 mm) dia socket (LLCR)	400 μΩ max.	GR-1217-CORE, 6.2.1
Low level contact resistance 0.150" (3,81 mm) dia socket (LLCR)	300 μΩ max.	GR-1217-CORE, 6.2.1
Low level contact resistance 0.180" (4,57 mm) dia sockets (LLCR)	200 μΩ max.	GR-1217-CORE, 6.2.1
<b>Thermal</b>		
Max socket temperature	248°F (120°C) max.	Max continuous use temperature for gold plating
Temperature rise	86°F (30°C) max.	GR-1217-CORE <sup>(Note2)</sup> EIA-364-70A <sup>(Note3)</sup>
<b>Environmental</b>		
Shock and vibration	SurfMate products are tested in random vibration environments to best simulate the broad spectrum of frequencies and amplitudes that may be encountered in typical applications. Actual system resonant frequencies will depend on PCB construction and mounting details. For critical, or unusual, shock and vibration environments, the performance of the system should be independently verified.	

Table 15-1 — SurfMate Specifications and Materials

(Note1) For 80 A operation with Maxi, contact Applications Engineering.

(Note3) ANSI/EIA-364 American National Standards Institute / Electronic Industries Association (Electronic Components, Assemblies & Materials Association)

(Note2) GR-1217-CORE issue 1, November 1995 Generic requirements for separable electrical connectors used in telecommunications hardware. A module of NEBSFR, FR-2063

(Note4) The module and socket must be replaced after 5 mating cycles.

Materials		Ratings	
<b>Headers</b>		Liquid Crystal Polymer	
Material: Vectra E150i LCP		UL94 V-0/5VA	
Flammability		500°F (260°C)	
Thermal stability (short term)		392°F (200°C)	
Thermal stability (long term)			
<b>Solder Cap</b>		260 cartridge brass (70 Cu, 30 Zn)	
Material		100 μ in. min. Cu, followed by 50 to 100 μ in. min. low stress sulfamate-based electrolytic nickel, followed by 20 μ in. min. soft gold	
Plating			
<b>Sockets</b>		Brush Wellman Alloy #25 C17200 deep draw quality or equiv. 0.010" thick	
Material		Woods nickel strike followed by 50 μ in. min. low stress sulfamate-based electrolytic nickel, followed by 20 μ in. min. hard gold, followed by 10 μ in. min. soft gold	
Plating			

**Table 15-2** — Material properties of SurfMate components

## SurfMates



**Figure 15-1** — SurfMates; Five pair sets



**Figure 15-2** — SurfMates; Individual part numbers

Package	Maxi	Mini	Micro	Notes
Five pair sets	16017	16021	16025	Inputs and outputs for five modules
Individual part numbers				
Input	22100	22100	22103	Sold only in multiples of 35 Maxi, Mini, or 40 Micro. Shipped in JEDEC trays
Output	22101	22102	22104	

**Table 15-3** — SurfMates: Part numbering and packaging

[Link to SurfMate PCB layout drawings and outline drawings for Maxi, Mini and Micro](#)

**Module Exchange Tool**

Used in facilitating the proper extraction of modules from InMate or SurfMate sockets.  
**Removal without using the Exchange Tool may cause damage to the sockets.**

Description	Part Number
Maxi Exchange Tool	22827
Mini Exchange Tool	22828
Micro Exchange Tool	22829

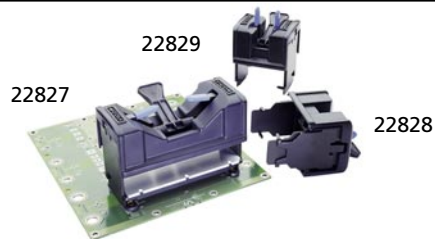

**Standoff Kits for SurfMate Mounted Modules**

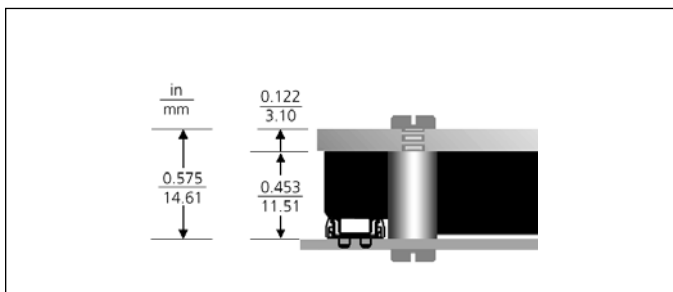

Figure 15-3 — Slotted baseplate; Height above board with standoff

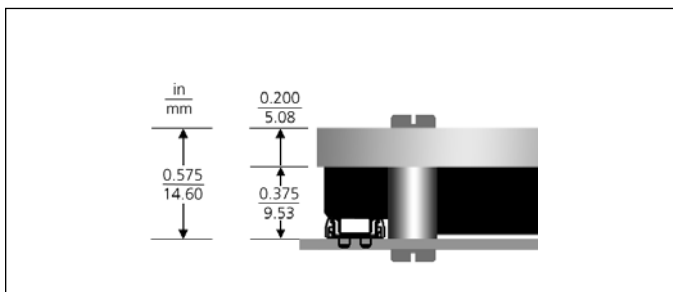

Figure 15-4 — Through-hole or threaded baseplate; Height above board with standoff

Heat Sinks	Module Kit #	100 Piece Kit
Slotted Baseplate		
Through-hole	20178	20188
Threaded	20179	20189
Through-hole Baseplate		
Through-hole	20176	20186
Threaded	20177	20187
No heat sink	20184	20186
Threaded Baseplate		
Through-hole	20176	20186
Threaded	N/A	N/A
No heat sink	20184	20186

Table 15-4 — Standoff kits for SurfMate mounted modules: Part numbering and packaging; Module kits contain enough standoffs and screws for one module. 100 piece kits contain standoffs only.

**Standoff Kits for SurfMate Mounted Modules\***

Board Thickness	Mounting Options	Slotted Baseplate		Through-Hole Baseplate		Threaded Baseplate
		Through-Hole Heat Sink	Threaded Heat Sink	Through-Hole Heat Sink	Threaded Heat Sink	Through-Hole Heat Sink
All	Surface Mount	Kit-20178	Kit-20179	Kit-20176	Kit-20177	Kit-20176
		Bag-20188	Bag-20189	Bag-20186	Bag-20187	Bag-20186

\* Kits include six (6) standoffs and screws. Mini and Micro modules require a minimum of four (4) standoffs. Bags of one hundred (100) do not include screws; #4-40 thread hardware required.

InMates are an innovative solution for through-hole socket requirements. Consisting of individual plastic carriers for the input and the output, each contains an array of sockets for either a full, half or quarter-brick sized module. The sockets are factory loaded into the carrier, which holds them rigidly in place throughout the assembly and soldering process. The carriers are later removed, leaving the sockets accurately positioned.

Designed for use with pin-compatible Maxi, Mini, and Micro Family converters, InMates are available for a wide range of PCB sizes and mounting styles. PCB thicknesses can range from 0.055" (1,39 mm) to 0.1375" (3,49 mm).

Sockets also allow for mounting modules either inboard, with a cutout in the PCB for the module, to minimize the height above the board, or onboard. InMates are compatible with the ModuMate or RoHS pin style.

InMates are available in standard recyclable JEDEC style trays for use with automated pick-and-place equipment and are compatible with most standard wave or hand solder operations. The sockets are soldered into the board as part of the PCB assembly process. The module can then be plugged into place at anytime later.

**NOTE:** Please refer to [Section 13](#) of the design guide for the InMate soldering procedure.

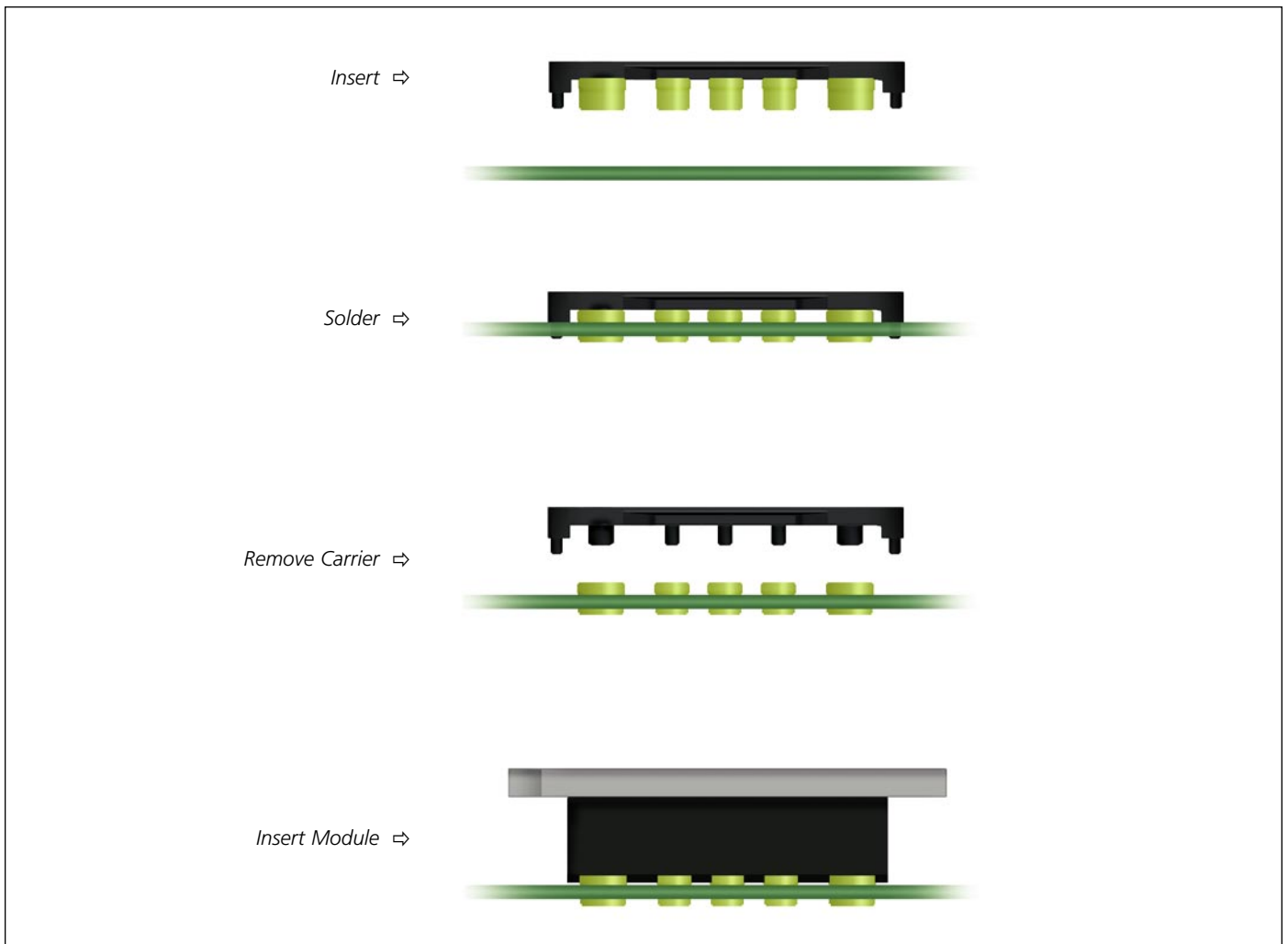

Figure 16-1 — InMate carrier / socket assembly and soldering process

InMate: Through-hole Sockets											
Board Thickness	Mounting Style	Full Brick (Maxi)			Half Brick (Mini)			Quarter Brick (Micro)			Pin Style
Norm. (Min. / Max.)		Input	Output	5 Sets	Input	Output	5 Sets	Input	Output	5 Sets	
0.062" (0.055" / 0.071") 1,5 mm (1,4 mm / 1,8 mm)	Inboard	18374	18382	18362	18374	18384	18366	18376	18386	18370	S or F
	Onboard	18378	18388	18364	18378	18390	18368	18380	18392	18372	N or G
0.093" (0.084" / 0.104") 2,4 mm (2,1 mm / 2,6 mm)	Inboard	18375	18383	18363	18375	18385	18367	18377	18387	18371	S or F
	Onboard	18379	18389	18365	18379	18391	18369	18381	18393	18373	N or G
0.125" (0.1125" / 0.1375") 3,1 mm (2,8 mm / 3,5 mm)	Onboard	21539	21543	21510	21539	21544	21511	21540	21545	21512	N or G

Table 16-1 — Guide to InMate selection

- Select Board Thickness.**  
Nominal 0.062" (1,5 mm), 0.093" (2,4 mm) or 0.125" (3,1 mm).
- Select Mounting Style.**  
Inboard requires a PCB cutout for the "belly" of the module. See dotted lines in PCB drawing links on Page 80 for cut out area.
- Identify Module Type.**  
Full brick (Maxi), half brick (Mini) or quarter brick (Micro).
- Select the Ordering Part Number.**  
Order packages of five input / output sets or in higher quantities order input and output InMates separately. For individual input or output InMates, minimum orders of 35 for Maxi or Mini and 40 for Micro apply.
- Verify Correct Pin Style for the Module.**  
For predefined parts, "S" or "F" = short ModuMate and "N" or "G" = long ModuMate  
See Table 16-4 for standoff recommendations.

Parameter	Specification Value	Reference
<b>Compatibility</b> Module pin styles	F = short Au plated S = short Au plated	Short RoHS pins Short ModuMate pins
	G = long Au plated N = long Au plated	Long RoHS pins Long ModuMate pins
<b>Mechanical</b> Contact normal force	100 grams EOL min.	GR-1217-CORE, R5-23
Number of mating cycles	5 max. <sup>(Note4)</sup>	Exception to GR-1217-CORE which specifies 25 mating cycle
Module engagement force	32 lbs per connector max.	GR-1217-CORE, R5-31,32
Module disengagement force	32 lbs per connector max.	GR-1217-CORE, R5-31,32
<b>Electrical</b> Current rating for output pin sockets	50 A Maxi <sup>(Note1)</sup> / 50 A Mini / 25 A Micro (Based on 248°F (120°C) max socket temp. & 86°F (30°C) max temperature rise of contact)	Gold plating standards, and accepted industry standards such as IICIT, EIA, Bellcore guidelines
Low level contact resistance 0.080" (2,03 mm) dia socket (LLCR)	400 μΩ max.	GR-1217-CORE, 6.2.1
Low level contact resistance 0.150" (3,81 mm) dia socket (LLCR)	300 μΩ max.	GR-1217-CORE, 6.2.1
Low level contact resistance 0.180" (4,57 mm) dia sockets (LLCR)	200 μΩ max.	GR-1217-CORE, 6.2.1
<b>Thermal</b> Max socket temperature	248°F (120°C) max.	Max continuous use temperature for gold plating
Temperature rise	86°F (30°C) max. EIA-364-70A <sup>(Note2)</sup>	GR-1217-CORE <sup>(Note3)</sup>
<b>Environmental</b> Shock and vibration	InMate products are tested in random vibration environments to best simulate the broad spectrum of frequencies and amplitudes that may be encountered in typical applications. Actual system resonant frequencies will depend on PCB construction and mounting details. For critical, or unusual, shock and vibration environments, the performance of the system should be independently verified.	

**Table 16-2** — InMate specifications and materials

Materials	Ratings
<b>Headers</b> Material: Ryton™ R-7 PPS, 65% glass fiber and mineral filled compound	Poly-Phenylene Sulfide
Flammability	UL94 V-0/5VA
Thermal stability (short term)	500°F (260°C)
Thermal stability (long term)	392°F (200°C)
<b>Solder Cap</b> Material	305 stainless steel
Plating	Clear passivate to repel solder
<b>Sockets</b> Material	Brush Wellman Alloy #25 C17200 deep draw quality or equiv. 0.010" thick
Plating	Woods nickel strike followed by 50 μ in. min. low stress sulfamate-based electrolytic nickel, followed by 20 μ in min hard gold followed by 10 μ in. min. soft gold

**Table 16-3** — Material properties of InMate components

(Note1) For 80 A operation with Maxi, contact Applications Engineering.

(Note2) GR-1217-CORE issue 1, November 1995 Generic requirements for separable electrical connectors used in telecommunications hardware. A module of NEBSFR, FR-2063

(Note3) ANSI/EIA-364 American National Standards Institute / Electronic Industries Association (Electronic Components, Assemblies & Materials Association)

(Note4) The module and socket must be replaced after 5 mating cycles.

Standoff Kits for InMate Mounted Modules*						
Board Thickness		Slotted Baseplate		Through-Hole Baseplate		Threaded Baseplate
Nom. (Min. / Max.)	Mounting Style	Through-Hole Heat Sink	Threaded Heat Sink	Through-Hole Heat Sink	Threaded Heat Sink	Through-Hole Heat Sink
0.062" (0.055"/0.071") 1,5 mm (1,4 mm / 1,8 mm)	Inboard	Kit - 18153 Bag - 19129	Kit - 18154 Bag - 19130	Kit - 18148 Bag - 19124	Kit - 18149 Bag - 19125	Kit - 18148 Bag - 19124
	Onboard	Kit - 18158 Bag - 19134	Kit - 18159 Bag - 19135	Kit - 18153 Bag - 19129	Kit - 18155 Bag - 19131	Kit - 18153 Bag - 19129
0.093" (0.084"/0.104") 2,4 mm (2,1 mm / 2,6 mm)	Inboard	Kit - 18153 Bag - 19129	Kit - 18154 Bag - 19130	Kit - 18148 Bag - 19124	Kit - 18149 Bag - 19125	Kit - 18148 Bag - 19124
	Onboard	Kit - 18156 Bag - 19132	Kit - 18157 Bag - 19133	Kit - 18150 Bag - 19126	Kit - 18152 Bag - 19128	Kit - 18150 Bag - 19126
0.125" (0.113"/0.138") 3,1 mm (2,8 mm / 3,5 mm)	Onboard	Kit - 18153 Bag - 19129	Kit - 18154 Bag - 19130	Kit - 18148 Bag - 19124	Kit - 18149 Bag - 19125	Kit - 18148 Bag - 19124
		Kit - 24054 Bag - 19132	Kit - 18157 Bag - 19133	Kit - 24056 Bag - 19126	Kit - 18152 Bag - 19128	Kit - 24056 Bag - 19126

Table 16-4 — InMate standoff recommendations

\* Kits include six (6) standoffs and screws. Mini and Micro modules require a minimum of four (4) standoffs. Bags of one hundred (100) do not include screws; #4-40 thread hardware required.

References
InMate PCB layout drawing for Maxi Module <a href="http://asp.vicorpower.com/cadUtil/display_cad.asp?pn=18400&amp;ct=PDF">http://asp.vicorpower.com/cadUtil/display_cad.asp?pn=18400&amp;ct=PDF</a>
InMate PCB layout drawing for Mini Module <a href="http://asp.vicorpower.com/cadUtil/display_cad.asp?pn=18399&amp;ct=PDF">http://asp.vicorpower.com/cadUtil/display_cad.asp?pn=18399&amp;ct=PDF</a>
InMate PCB layout drawing for Micro Module <a href="http://asp.vicorpower.com/cadUtil/display_cad.asp?pn=18398&amp;ct=PDF">http://asp.vicorpower.com/cadUtil/display_cad.asp?pn=18398&amp;ct=PDF</a>
InMate and Socket outline drawing for Inboard Maxi Modules <a href="http://asp.vicorpower.com/cadUtil/display_cad.asp?pn=18483-XX&amp;ct=PDF">http://asp.vicorpower.com/cadUtil/display_cad.asp?pn=18483-XX&amp;ct=PDF</a>
InMate and Socket outline drawing for Inboard Mini Modules <a href="http://asp.vicorpower.com/cadUtil/display_cad.asp?pn=18482-XX&amp;ct=PDF">http://asp.vicorpower.com/cadUtil/display_cad.asp?pn=18482-XX&amp;ct=PDF</a>
InMate and Socket outline drawing for Inboard Micro Modules <a href="http://asp.vicorpower.com/cadUtil/display_cad.asp?pn=18481-XX&amp;ct=PDF">http://asp.vicorpower.com/cadUtil/display_cad.asp?pn=18481-XX&amp;ct=PDF</a>
InMate and Socket outline drawing for Onboard Maxi Modules <a href="http://asp.vicorpower.com/cadUtil/display_cad.asp?pn=18480-XX&amp;ct=PDF">http://asp.vicorpower.com/cadUtil/display_cad.asp?pn=18480-XX&amp;ct=PDF</a>
InMate and Socket outline drawing for Onboard Mini Modules <a href="http://asp.vicorpower.com/cadUtil/display_cad.asp?pn=20030-XX&amp;ct=PDF">http://asp.vicorpower.com/cadUtil/display_cad.asp?pn=20030-XX&amp;ct=PDF</a>
InMate and Socket outline drawing for Onboard Micro Modules <a href="http://vda2.vicor.com/cadUtil/display_cad.asp?pn=20029-XX&amp;ct=PDF">http://vda2.vicor.com/cadUtil/display_cad.asp?pn=20029-XX&amp;ct=PDF</a>

Module Exchange Tool									
Used in facilitating the proper extraction of modules from InMate or SurfMate sockets. <b>Removal without using the Exchange Tool may cause damage to the sockets.</b>									
<table border="1"> <thead> <tr> <th>Description</th> <th>Part Number</th> </tr> </thead> <tbody> <tr> <td>Maxi Exchange Tool</td> <td>22827</td> </tr> <tr> <td>Mini Exchange Tool</td> <td>22828</td> </tr> <tr> <td>Micro Exchange Tool</td> <td>22829</td> </tr> </tbody> </table>	Description	Part Number	Maxi Exchange Tool	22827	Mini Exchange Tool	22828	Micro Exchange Tool	22829	
Description	Part Number								
Maxi Exchange Tool	22827								
Mini Exchange Tool	22828								
Micro Exchange Tool	22829								

**A**

**AC-OK Signal.** The signal used to indicate the loss of AC input voltage from the 115 / 230 V line.

**Altitude Testing.** Generally performed to determine the proper functionality of equipment in airplanes and other flying objects. MIL-STD-810.

**Ambient Temperature.** The temperature of the environment, usually the still air in the immediate proximity of the power supply.

**Apparent Power.** A value of power for AC circuits that is calculated as the product of rms current times rms voltage, without taking power factor into account.

**B**

**Bandwidth.** A range of frequencies over which a certain phenomenon is to be considered.

**Baseplate.** All modular products have an aluminum mounting base at which Vicor specifies operating temperatures and which should be affixed to a thermally conductive surface for cooling.

**Bellcore Specification.** A telecommunications industry standard developed by Bellcore.

**Bipolar Transistor.** A transistor that operates by the action of minority carriers across a PN junction; and is a current controlled device as opposed to a voltage controlled device.

**Bleeder Resistor.** A resistor added to a circuit for the purpose of providing a small current drain, to assure discharge of capacitors.

**Bobbin.** A device upon which the windings of a transformer or inductor are wound, it provides a form for the coil and insulates the windings from the core.

**Booster Converter.** A "slave" module in a Driver / Booster combination, where the Driver is the master. Several Boosters can be paralleled with a Driver module for higher output power.

**Breakdown Voltage.** A voltage level at which dielectric insulation fails by excessive leakage current or arcing. In reference to power supplies the breakdown voltage is the maximum AC or DC voltage that can be applied from input to output and / or chassis.

**Bridge Converter.** A DC-DC converter topology (configuration) employing two or four active switching components in a bridge configuration across a power transformer.

**Bridge Rectifier.** A full wave rectifier circuit employing four rectifiers in a bridge configuration.

**British Telecom Standards.** A telecommunications industry standard developed by the British PTT authorities.

**Brownout.** A reduction of the AC mains distribution voltage, usually caused deliberately by the utility company to reduce power consumption when demand exceeds generation or distribution capacity.

**Burn-In.** Operating a newly manufactured power supply, usually at rated load, for a period of time in order to force component infant mortality failures or other latent defects.

**C**

**Capacitive Coupling.** Coupling of a signal between two circuits, due to discrete or parasitic capacitance between the circuits.

**Center Tap.** An electrical connection made at the center of a transformer or inductor winding, usually so as to result in an equal number of turns on either side of the tap.

**Centralized Power Architecture (CPA).** One of the oldest power systems architectures, generates all system voltages at a central location and distributes them to load locations via distribution buses. This can be effective if the voltages are high and the currents low or if the distances between the power supply and the loads are small.

**C-Grade.** Industry standard where the operating temperature of a device does not drop below  $-20^{\circ}\text{C}$ .

**Chassis Mount Configuration.** A configuration where the modules or AC front ends are mounted directly to the chassis.

**Common-Mode Noise.** Noise present equally on two conductors with respect to some reference point; often used specifically to refer to noise present on both the hot and neutral AC lines with respect to ground.

**ComPAC.** A Vicor DC input power supply that provides EMC filtering and transient suppression for industrial, military and telecommunications markets.

**Constant Current Power Supply.** A power supply designed to regulate output current for changes in line, load, ambient temperature and drift resulting from time.

**Constant Voltage Power Supply.** A power supply designed to regulate output voltage for changes in line, load, ambient temperature and drift resulting from time.

**Control Circuit.** A circuit in a closed-loop system, typically containing an error amplifier, that controls the operation of the system to achieve regulation.

**Converter.** An electrical circuit that accepts a DC input and generates a DC output of a different voltage usually achieved by high frequency switching action employing inductive and capacitive filter elements.

**Crest Factor.** In an AC circuit, the mathematical ratio of the peak to rms values of a waveform. Crest factor is sometimes used for describing the current stress in AC mains supply wires, since for a given amount of power transferred, the rms value, and hence the losses, become greater with increasing peak values. Crest factor gives essentially the same information as power factor, and is being replaced by power factor in power supply technology.

**Cross Regulation.** The effect of a load change on one output to the regulation of another output. It usually only applies to non postregulated (quasi) outputs.

**Crowbar.** An overvoltage protection method that shorts the power supply output to ground in order to protect the load when an overvoltage fault is detected.

**CSA.** Canadian Standards Association. Defines the standards and safety requirements for power components.

**Current Limiting.** An overload protection circuit that limits the maximum output current of a power supply in order to protect the load and / or the power supply.

**Current Mode.** A control method for switch-mode converters where the converter adjusts its regulating pulsewidth in response to measured output current and output voltage, using a dual loop control circuit.

**Current Monitor.** An analog power supply signal that is linearly proportional to output current flow.

## D

**DC-OK Signal.** Signal used to monitor the status of the DC output.

**Derating.** A reduction in an operating specification to improve reliability. For power supplies it is usually a specified reduction in output power to facilitate operation at higher temperatures.

**Design Life.** The expected lifetime of a power supply during which it will operate to its published specifications.

**Differential-Mode Noise.** Noise that is measured between two lines with respect to a common reference point excluding common-mode noise. The resultant measurement is the difference of the noise components of the two lines. The noise between the DC output and DC return is usually measured in power supplies.

**Distributed Power Architecture (DPA).** A power distribution architecture that replaces multiple central

power sources with a single bulk supply that is converted to the end-use voltages by DC-DC converters located at the point of need. The growth of this design technique is demonstrated by the size of the DC-DC converter market. Distributed power can reduce the system size, reduce the system weight, provide better operation with battery power, and deliver more efficient sub-system isolation and redundancy.

**Drift.** The change in an output voltage, after a warm-up period, as a function of time when all other variables such as line, load, and operating temperature are held constant.

**Driver Module.** The controlling module in a standalone or Driver / Booster configuration. The Driver module contains all the control circuitry.

**Dropout.** The lower limit of the AC input voltage where the power supply just begins to experience insufficient input to maintain regulation. The dropout voltage for linears is largely line dependent, whereas for most switchers it is largely load dependent, and to a smaller degree line dependent.

**Dynamic Load Regulation.** The delta in output voltage when the output load is rapidly changed.

## E

**Efficiency.** The ratio of total output power to input power expressed as a percentage.

**Electronic Load.** An electronic device designed to provide a load to the outputs of a power supply, usually capable of dynamic loading, and frequently programmable or computer controlled.

**EMC.** Electromagnetic Compatibility. Relating to compliance with electromagnetic emissions and susceptibility standards.

**EMI.** Electromagnetic Interference. The generation of unwanted noise during the operation of a power supply or other electrical or electronic equipment.

**ESR.** Equivalent Series Resistance. The value of resistance in series with an ideal capacitor that duplicates the performance characteristics of a real capacitor.

## F

**Factorized Power Architecture (FPA).** A power distribution architecture that is inherently more granular and leverages an allocation of the DC-DC converter functions consistent with efficient power distribution principles. An optimal power distribution architecture should efficiently support demanding low voltage, high current loads. FPA is a higher level power architecture that offers dramatic improvements in onboard power distribution systems, in performance, reliability and economy.

**Fault Tolerant Configuration.** A method of parallel operation, using output Oring diodes, in which the failure of a single supply (module) will not result in a loss of power. The total current of the parallel system must not exceed the load requirements to a point where the failure of a single unit will not result in a system overload.

**FET.** Field Effect Transistor. A majority carrier-voltage controlled transistor.

**FinMod.** A flangeless /finned packaging option available on Vicor's VI-/MI-Family converters and accessory modules.

**FlatPAC.** A Vicor AC-DC switcher available with one, two or three outputs, with total power rating from 50 – 600 W.

**Floating Output.** An output of a power supply that is not connected or referenced to any other output, usually denoting full galvanic isolation. Floating outputs can generally be used as either positive or negative outputs. Non floating outputs share a common return line and are hence DC referenced to one another.

**Foldback Current Limiting.** A type of protection circuit where the output current decreases as the overload increases. The output current reaches a minimum as the load approaches a short circuit condition.

**Forward Converter.** A switching power supply in which the energy is transferred from the input to the output during the "on" time of the primary switching device.

## G

**GATE IN.** The GATE IN pin of the module may be used to turn the module on or off. When GATE IN is pulled low, the module is turned off. When GATE IN is floating (open collector) the module is turned on. The open circuit voltage of the GATE IN pin is less than 10 V, referenced to  $-V_{in}$ . A GATE OUT / GATE IN connection is necessary to run Driver / Booster configurations.

**GATE OUT.** The GATE OUT pin is the clock pulse of the converter. It is used to synchronize Booster modules to a Driver module for high power arrays.

**Ground.** An electrical connection to earth or some other conductor that is connected to earth. Sometimes the term "ground" is used in place of "common," but such usage is not correct unless the connection is also connected to earth.

**Ground Loop.** An unintentionally induced feedback loop caused by two or more circuits sharing a common electrical ground.

## H

**Haversine.** A waveform that is sinusoidal in nature, but consists of a portion of a sine wave superimposed on another waveform. The input current waveform to a typical offline power supply has the form of a haversine.

**Headroom.** Used in conjunction with series pass regulators, headroom is the difference between the input and output voltages.

**Heat Sink.** A medium of high thermal mass that can absorb (sink) heat indefinitely with negligible change in temperature. Heat sinks are not necessarily needed with Vicor modules, and their use is highly dependent on the individual application, power and ambient temperature.

**High Line Input.** The maximum steady-state input voltage on the input pin.

**Hipot.** Abbreviation for high potential, and generally refers to the high voltages used to test dielectric withstand capability for regulatory agency electrical safety requirements.

**Hold-Up Capacitor.** A capacitor whose energy is used to provide output voltage for a period after the removal of input voltage.

**Hold-Up Time.** The length of time a power supply can operate in regulation after failure of the AC input. Linears have very short hold-up times due to the energy stored on the low-voltage secondary side output capacitors. Switchers have longer times due to higher-voltage primary-side energy storage capacitors.

**Hot Swap.** Insertion and extraction of a power supply into a system while power is applied.

## I

**I-Grade.** Industry standard where the operation temperature of a device does not drop below  $-40^{\circ}\text{C}$ .

**Impedance.** The ratio of voltage to current at a specified frequency.

**Induced Noise.** Noise generated in a circuit by varying a magnetic field produced by another circuit.

**Input Line Filter.** An internally or externally mounted lowpass or band-reject filter at the power supply input that reduces the noise fed into the power supply.

**Inrush Current.** The peak current flowing into a power supply the instant AC power is applied. This peak may be much higher than the steady state input current due to the charging of the input filter capacitors.

**Inrush Current Limiting.** A circuit that limits the amount of inrush current when a power supply is turned on.

**Isolation.** Two circuits that are completely electrically separated with respect to DC potentials, and almost always AC potentials. In power supplies, it is defined as the electrical separation of the input and output via the transformer.

**Isolation Voltage.** The maximum AC or DC test voltage that may be applied from input to output and / or chassis of a power supply. Usually this has a time limit per preregulatory agency such as EN60950.

**Intermediate Bus Architecture (IBA).** A power distribution architecture that relies on non-isolated point-of-load regulators (niPOLs), reducing the POL function to regulation and transformation. The niPOLs operate from an intermediate bus voltage provided by upstream isolated converters. However, IBA has inherent limitations that require tradeoffs between distribution and conversion loss that limit responsiveness to rapid load changes. IBA has proven effective as an interim method of containing power system cost while addressing the trend toward a proliferation of lower load voltages.

## L

**Leakage Current.** A term relating to current flowing between the AC supply wires and earth ground. The term does not necessarily denote a fault condition. In power supplies, leakage current usually refers to the 60 Hz current that flows through the EMC filter capacitors connected between the AC lines and ground (Y caps).

**Linear Regulator.** A regulating technique where a dissipative active device such as a transistor is placed in series with a power supply output to regulate the output voltage.

**Line Regulation.** The change in output voltage when the AC input voltage is changed from minimum to maximum specified.

**Line Voltage (Mains).** The sine wave voltage provided to the power supply, usually expressed in volts rms.

**Load Regulation.** The change in output voltage when the load on the output is changed.

**Local Sensing.** Using the voltage output terminals of the power supply as sense points for voltage regulation.

**Long Term Stability.** Power supply output voltage change due to time with all other factors held constant. This is expressed in percent and is a function of component aging.

**Low Line.** The minimum steady state voltage that can be applied between the +IN and -IN pins of a converter and still maintain output regulation.

## M

**Mains.** The utility AC power distribution wires.

**Margining.** Adjusting a power supply output voltage up or down from its nominal setting in order to verify system performance margin with respect to supply voltage. This is usually done electrically by a system-generated control signal.

**MegaMod.** A chassis mount packaging option that incorporates one, two or three VI-/MI-200 Family converters for single, dual or triple outputs having a combined power of up to 600 W.

**M-Grade.** An industry standard where the operating temperature of a device does not drop below  $-55^{\circ}\text{C}$ .

**MIL-SPECS.** Military standards that a device must meet to be used in military environments.

**MiniMod.** A junior size (VI-/MI-J00) version of the VI-/MI-200 Family of DC-DC converters offering up to half the power in a 2.28" x 2.4" x 0.5" (57,9 x 61,0 x 12,7 mm) package.

**Minimum Load.** The minimum load current / power that must be drawn from the power supply in order for the supply to meet its performance specifications. Less frequently, a minimum load is required to prevent the power supply from failing.

**Module Evaluation Board.** A test fixture used to evaluate Vicor DC-DC converters.

**MTBF (Mean Time Between Failure).** MTBF is the point at which 63% of a given population no longer meet specification. It can either be calculated or demonstrated. The usual calculation is per MIL-STD-217 Rev. E. Demonstrated reliability is usually determined by temperature accelerated life testing and is usually greater than calculated MTBF.

**N**

**Nominal Input.** The center value for the input voltage range.

**Nominal Value.** A usual, average, normal, or expected operating condition. This stated value will probably not be equal to the value actually measured.

**O**

**Offline.** A power supply that receives its input power from the AC line, without using a 50 / 60 Hz power transformer prior to rectification and filtering, hence the term "offline" power supply.

**Open Frame.** A power supply where there is no external metal chassis; the power supply is provided to the end user essentially as a printed circuit board that provides mechanical support as well as supporting the components and making electrical connections.

**Operating Temperature.** The range of temperatures in which a unit can operate within specifications.

**Optoisolator.** An electro-optical device that transmits a signal across a DC isolation boundary.

**ORing Diodes.** Diodes used to isolate supplies from one another under a fault condition.

**Output Filtering.** Filter used to reduce switching power supply noise and ripple.

**Output Good.** A power supply status signal that indicates the output voltage is within a certain tolerance. An output that is either too high or too low will deactivate the Output Good signal.

**Output Impedance.** The ratio of change in output voltage to change in load current.

**Output Noise.** The AC component that may be present on the DC output of a power supply. Switch-mode power supply output noise usually has two components: a lower frequency component at the switching frequency of the converter and a high frequency component due to fast edges of the converter switching transitions. Noise should always be measured directly at the output terminals with a scope probe having an extremely short grounding lead.

**Output Power Rating.** The maximum power in watts that the power supply can provide and still maintain safety agency approvals.

**Output Voltage Accuracy.** See Setpoint Accuracy.

**Overload Protection.** A power supply protection circuit that limits the output current under overload conditions.

**Overshoot.** A transient output voltage change exceeding the high limit of the voltage accuracy specification caused by turning the power supply on or off, or abruptly changing line or load conditions.

**Overtemp Warning.** A TTL compatible signal that indicates an overtemperature condition exists in the power supply.

**Overvoltage Protection (OVP).** A circuit that either shuts down the power supply or crowbars the output in the event of an output overvoltage condition.

**P**

**Parallel Boost.** VI-/MI-200 Family Booster modules may be added to a Driver to create multi-kilowatt arrays. Boosters do not contain any feedback or control circuitry.

**Parallel Operation.** Connecting the outputs of two or more power supplies together for the purpose of obtaining a higher output current. This requires power supplies specially designed for load sharing.

**PARD.** Periodic And Random Deviation. Referring to the sum of all ripple and noise components on the DC output of a power supply, regardless of nature or source.

**Peak Power.** The absolute maximum output power that a power supply can produce without immediate damage. Peak power capability is typically well beyond the continuous output power capability and the resulting average power should not exceed rated specifications.

**Pi Filter.** A commonly used filter at the input of a switching supply or DC-DC converter to reduce reflected ripple current. The filter usually consists of two shunt capacitors with inductance between them.

**Post Regulator.** A secondary regulating circuit on an auxiliary output of a power supply that provides regulation on that output.

**Power Fail.** A power supply interface signal that gives a warning that the input voltage will no longer sustain full power regulated output.

**Power Factor.** The ratio of true power to apparent power in an AC circuit. In power conversion technology, power factor is used in conjunction with describing AC input current to the power supply.

**Preload.** A small amount of current drawn from a power supply to stabilize its operation.

**Primary.** The input section of an isolated power supply, it is connected to the AC mains and hence has dangerous voltage levels present.

**Product Grade.** The environmental and acceptance tests performed on Vicor products.

**Pulse Width Modulation (PWM).** A switching power conversion technique where the on-time (or width) of a duty cycle is modulated to control power transfer for regulating power supply outputs.

**Push-Pull Converter.** A switch-mode power supply topology that utilizes a center-tapped transformer and two power switches. The two switches are alternately driven on and off.

## Q

**Quasi-Regulated Output.** The regulation of an auxiliary output that is accomplished by regulation of the main output. A transformer turns ratio, commensurate with the desired auxiliary output voltage, is used in conjunction with the output around which the main control loop is closed. Quasi-regulated outputs are significantly affected by second order effects in the converter.

## R

**Rated Output Current.** The maximum load current that a power supply can provide at a specified ambient temperature.

**Reflected Ripple Current.** The rms or peak-to-peak AC current present at the input of the power supply that is a result of the switching frequency of the converter.

**Regulation.** The ability of a power supply to maintain an output voltage within a specified tolerance as referenced to changing conditions of input voltage and / or load.

**Regulation Band.** The total error band allowable for an output voltage. This includes the effects of all of the types of regulation: line, load, temperature and time.

**Regulatory Agencies.** CSA: Canadian Standards Association; FCC: Federal Communications Commission; FTZ: Fernmelde Technisches Zentralamt; TÜV: Technischer Überwachungs Verein; U.L.: Underwriters Laboratory; VDE: Verband Deutscher Electrotechniker.

**Remote Inhibit.** A power supply interface signal, usually TTL compatible, that commands the power supply to shut down one or all outputs.

**Remote On/Off.** Enables power supply to be remotely turned on or off. Turn-on is typically performed by open circuit or TTL logic "1", and turn-off by switch closure or TTL logic "0".

**Remote Sense.** Wires connected in parallel with power supply output cables such that the power supply can sense the actual voltage at the load to compensate for voltage drops in the output cables and / or isolation devices.

**Return.** The designation of the common terminal for the power supply outputs. It carries the return current for the outputs.

**Reverse Voltage Protection.** A protection circuit that prevents the power supply from being damaged in the event that a reverse voltage is applied at the input or output terminals.

**RFI.** Radio Frequency Interference. Undesirable noise produced by a power supply or other electrical or electronic device during its operation. In power supply technology, RFI is usually taken to mean the same thing as EMC.

**Ripple and Noise.** The amplitude of the AC component on the DC output of a power supply usually expressed in millivolts peak-to-peak or rms. For a linear power supply it is usually at the frequency of the AC mains. For a switching power supply, it is usually at the switching frequency of the converter stage.

## S

**Safety Ground.** A conductive path to earth that is designed to protect persons from electrical shock by shunting away any dangerous currents that might occur due to malfunction or accident.

**Secondary.** The output section of an isolated power supply, it is isolated from the AC mains and specially designed for safety of personnel who might be working with power on the system.

**SELV.** An acronym for Safety Extra Low Voltage, a term generally defined by the regulatory agencies as the highest voltage that can be contacted by a person and not cause injury. It is often specifically defined as 30 Vac or 42.4 Vdc.

**Setpoint Accuracy.** Ratio of actual to specified output voltage.

**Sequencing.** The technique of establishing a desired order of activating the outputs of a multiple output power supply.

**Soft Start.** A technique for gradually activating a power supply circuit when the power supply is first turned on. This technique is generally used to provide a gradual rise in output voltages and inrush current limiting.

**Soft Line.** A condition where there is substantial impedance present in the AC mains feeding input power to a power supply. The input voltage to the power supply drops significantly with increasing load.

**Split Bobbin Winding.** A transformer winding technique where the primary and secondary are wound side-by-side on a bobbin with an insulation barrier between them.

**Standby Current.** The input current drawn by a power supply when shut down by a control input (remote inhibit) or under no load.

**Stiff Line.** A condition where there is no significant impedance present in the AC mains feeding input power to a power supply. The input voltage to the power supply does not change appreciably with load.

**Switching Frequency.** The rate at which the DC voltage is switched on and off in a switching power supply.

## T

**Temperature Coefficient.** The average output voltage change expressed as a percent per degree Celsius of ambient temperature change. This is usually specified for a predetermined temperature range.

**Temperature Derating.** Reducing the output power of a power supply with increasing temperature to maintain reliable operation.

**Thermal Pad.** A phase change material (ThermMate) used as a thermal interface between the converter and a heat sink or chassis.

**Thermal Protection.** A power supply protection circuit that shuts the power supply down in the event of unacceptably high internal temperatures.

**Topology.** The design type of a converter, indicative of the configuration of switching transistors, utilization of the transformer, and type of filtering. Examples of topologies are the Flyback, Forward, Half Bridge, Full Bridge, Resonant and Zero-Current-Switching.

**Tracking.** A characteristic in a multiple output power supply where any changes in the output voltage of one output caused by line, load, and / or temperature are proportional to similar changes in accompanying outputs.

**Transient Recovery Time.** The time required for an output voltage to be within specified accuracy limits after a step change in line or load conditions.

**True Power.** In an AC circuit, true power is the actual power consumed. It is distinguished from apparent power by eliminating the reactive power component that may be present.

## U

**Undershoot.** A transient output voltage change which does not meet the low limit of the voltage accuracy specification and is caused by turning the power supply on or off, or abruptly changing line or load conditions.

**Universal Input.** An AC input capable of operating from major AC lines worldwide, without straps or switches.

## V

**V•I Chip (VIC).** V•I Chips are the smallest power components available today — about the size of a 1/16 brick and very power dense. They can be used as building blocks to replace existing circuits (quarter bricks and silver box power supplies). V•I Chips offer flexible thermal management: a low thermal impedance package and the design of the package simplifies heat sink design. The name 'V•I Chips' comes from their ability to multiply currents and divide voltages while preserving the V•I power product (the "•") essentially constant.

**Voltage Balance.** The difference in magnitudes, in percent, of two output voltages that have equal nominal voltage magnitudes but opposite polarities.

**Voltage Mode.** A method of closed loop control of a switching converter to correct for changes in the output voltage.

## W

**Warm-Up Drift.** The initial change in the output voltage of a power supply in the time period between turn-on and when the power supply reaches thermal equilibrium at 25°C, full load and nominal line.

**Warm-Up Time.** The time required after initial turn-on for a power supply to achieve compliance to its performance specifications.

## X

**X-Capacitor.** A capacitor connected across the supply lines to suppress normal mode interference.

**Y**

**Y-Capacitor.** Power conversion modules generally require bypass capacitors from line to chassis (earth ground) to shunt common-mode noise currents and keep them local to the converter. In cases where the converters are operating from rectified AC line voltage, the failure of a bypass capacitor could result in excessive leakage current to the equipment chassis thus creating a ground fault and shock hazard. For this reason, a special classification of capacitor, referred to as a Y-capacitor, is recommended. These capacitors contain a dielectric with unique "self-healing" properties to help prevent against excessive leakage.

To meet general EMC requirements (Section 9), Vicor recommends the use of Y-capacitors with all power conversion modules. Y-capacitors meet IEC384-14, EN132400, and UL1283 standards.

**Z**

**Zero-Current-Switching.** The turn-on and turn-off of a switching device at zero current, resulting in essentially lossless switching. The zero-current-switching topology allows Vicor converters to operate at frequencies up to 1 MHz, with efficiencies higher than 80% and power densities greater than conventional topologies.

**Zero-Voltage-Switching.** This technique significantly minimizes the switching losses and dv/dt noise due to the discharge of the switching MOSFET junction capacitance and reverse recovery of the diode, and enables switch mode converters to operate at higher frequencies.

**Vicor's comprehensive line of power solutions includes high density AC-DC and DC-DC modules and accessory components, fully configurable AC-DC and DC-DC power supplies, and complete custom power systems.**

Information furnished by Vicor is believed to be accurate and reliable. However, no responsibility is assumed by Vicor for its use. Vicor components are not designed to be used in applications, such as life support systems, wherein a failure or malfunction could result in injury or death. All sales are subject to Vicor's Terms and Conditions of Sale, which are available upon request.

**Specifications are subject to change without notice.**

**Intellectual Property Notice**

Vicor and its subsidiaries own Intellectual Property (including issued U.S. and Foreign Patents and pending patent applications) relating to the products described in this data sheet. Interested parties should contact Vicor's Intellectual Property Department.

**Vicor Corporation**  
25 Frontage Road  
Andover, MA, USA 01810  
Tel: 800-735-6200  
Fax: 978-475-6715

**email**

Customer Service: [custserv@vicorpower.com](mailto:custserv@vicorpower.com)  
Technical Support: [apps@vicorpower.com](mailto:apps@vicorpower.com)

**[vicorpower.com](http://vicorpower.com)**