

# DRV8428 Stepper Driver With Integrated Current Sense, 1/256 Microstepping, STEP/DIR Interface and smart tune Technology

## 1 Features

- PWM Microstepping Stepper Motor Driver
  - Simple STEP/DIR Interface
  - Up to 1/256 Microstepping Indexer
- Integrated Current Sense Functionality
  - No Sense Resistors Required
  - $\pm 6\%$  Full-Scale Current Accuracy
- Smart tune decay technology and mixed decay options
- 4.2-V to 33-V Operating Supply Voltage Range
- $R_{DS(ON)}$ : 1500 m $\Omega$  HS + LS at 24 V, 25°C
- Current Capacity Per Bridge: 1.7-A peak, 1-A Full-Scale, 0.7-A rms
- Configurable Off-Time PWM Chopping
  - 7- $\mu$ s, 16- $\mu$ s, or 32- $\mu$ s.
- Supports 1.8-V, 3.3-V, 5.0-V Logic Inputs
- Low-Current Sleep Mode (2  $\mu$ A)
- Spread spectrum clocking for low electromagnetic interference (EMI)
- Small Package and Footprint
- Protection Features
  - VM Undervoltage Lockout (UVLO)
  - Overcurrent Protection (OCP)
  - Thermal Shutdown (OTSD)
  - Fault Condition Output (EN/nFAULT)

## 2 Applications

- [Printers and scanners](#)
- [Stage lighting equipment](#)
- Sewing machines
- [Security and dome cameras](#)
- [Office and home automation](#)
- [Factory automation and robotics](#)
- [Medical applications](#)

## 3 Description

The DRV8428 is a stepper motor driver for industrial and consumer applications. The device is fully integrated with two N-channel power MOSFET H-bridge drivers, a microstepping indexer, and integrated current sensing. The DRV8428 is capable of driving up to 1-A full-scale output current (dependent on PCB design).

The DRV8428 uses an internal current sense architecture to eliminate the need for two external power sense resistors, saving PCB area and system cost. The device uses an internal PWM current regulation scheme selectable between smart tune, and mixed decay options. Smart tune automatically

adjusts for optimal current regulation, compensates for motor variation and aging effects and reduces audible noise from the motor.

A simple STEP/DIR interface allows an external controller to manage the direction and step rate of the stepper motor. The device can be configured in different step modes ranging from full-step to 1/256 microstepping. A low-power sleep mode is provided for very low standby quiescent standby current using a dedicated nSLEEP pin. Protection features are provided for supply undervoltage, overcurrent, short circuits, and overtemperature. Fault conditions are indicated by the EN/nFAULT pin.

### Device Information<sup>(1)</sup>

PART NUMBER	PACKAGE	BODY SIZE (NOM)
DRV8428PWPR	HTSSOP (16)	5mm x 4.4mm
DRV8428RTER	WQFN (16)	3.0mm x 3.0mm

- (1) For all available packages, see the orderable addendum at the end of the data sheet.

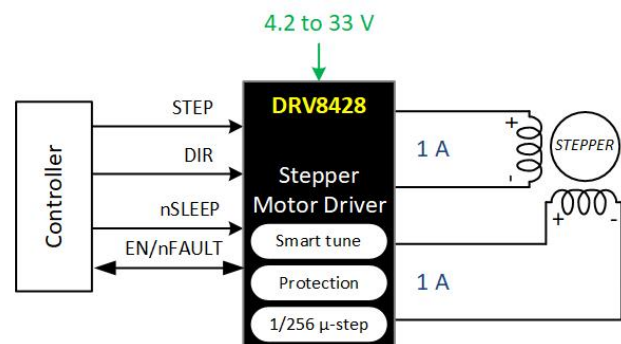

Simplified Schematic



## Table of Contents

<b>1 Features</b> .....	1	7.2 Functional Block Diagram.....	12
<b>2 Applications</b> .....	1	7.3 Feature Description.....	12
<b>3 Description</b> .....	1	7.4 Device Functional Modes.....	26
<b>4 Revision History</b> .....	2	<b>8 Application and Implementation</b> .....	27
<b>5 Pin Configuration and Functions</b> .....	3	8.1 Application Information.....	27
5.1 Pin Functions.....	3	8.2 Typical Application.....	27
<b>6 Specifications</b> .....	5	<b>9 Power Supply Recommendations</b> .....	34
6.1 Absolute Maximum Ratings.....	5	9.1 Bulk Capacitance.....	34
6.2 ESD Ratings.....	5	<b>10 Layout</b> .....	35
6.3 Recommended Operating Conditions.....	6	10.1 Layout Guidelines.....	35
6.4 Thermal Information.....	6	<b>11 Device and Documentation Support</b> .....	37
6.5 Electrical Characteristics.....	7	11.1 Receiving Notification of Documentation Updates..	37
6.6 Indexer Timing Requirements.....	8	11.2 Community Resources.....	37
6.7 Typical Characteristics.....	9	11.3 Trademarks.....	37
<b>7 Detailed Description</b> .....	11	<b>12 Mechanical, Packaging, and Orderable Information</b> .....	38
7.1 Overview.....	11		

## 4 Revision History

NOTE: Page numbers for previous revisions may differ from page numbers in the current version.

<b>Changes from Revision A (November 2020) to Revision B (May 2021)</b>	<b>Page</b>
• Corrected typo in <a href="#">Table 7-4</a> .....	14
• Removed duplicate package drawings.....	38

<b>Changes from Revision * (June 2020) to Revision A (November 2020)</b>	<b>Page</b>
• Changed device status to production data.....	1

## 5 Pin Configuration and Functions

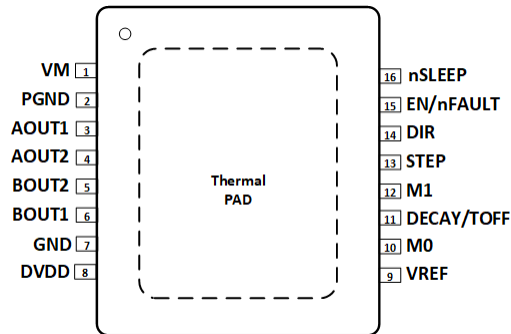

Figure 5-1. PWP PowerPAD™ Package 16-Pin HTSSOP Top View

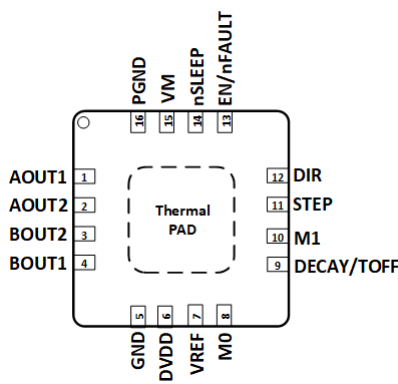

Figure 5-2. RTE Package 16-Pin WQFN with Exposed Thermal PAD Top View

### 5.1 Pin Functions

NAME	PIN NO.		I/O	TYPE	DESCRIPTION
	HTSSOP	WQFN			
AOUT1	3	1	O	Output	Winding A output. Connect to stepper motor winding.
AOUT2	4	2	O	Output	Winding A output. Connect to stepper motor winding.
PGND	2	16	PWR	Power	Power ground. Connect to system ground.
BOUT2	5	3	O	Output	Winding B output. Connect to stepper motor winding
BOUT1	6	4	O	Output	Winding B output. Connect to stepper motor winding
DIR	14	12	I	Input	Direction input. Logic level sets the direction of stepping; internal pulldown resistor.
EN/nFAULT	15	13	I/O	Input/Output	Logic low to disable device outputs; logic high to enable. Also used for fault indication. Pulled logic low in fault condition.
DVDD	8	6	PWR	Power	Logic supply voltage. Connect a X7R, 0.47- $\mu$ F to 1- $\mu$ F, 6.3-V or 10-V rated ceramic capacitor to GND.
GND	7	5	PWR	Power	Device ground. Connect to system ground.
VREF	9	7	I	Input	Current set reference input. Maximum value 3 V. DVDD can be used to provide VREF through a resistor divider.
M0	10	8	I	Input	Microstepping mode-setting pins. Sets the step mode; internal pulldown resistor.
M1	12	10			
DECAY/TOFF	11	9	I	Input	Decay-mode and off-time setting pin. See the <a href="#">Section 7.3.5</a> section for details.

NAME	PIN		I/O	TYPE	DESCRIPTION
	NO.				
	HTSSOP	WQFN			
STEP	13	11	I	Input	Step input. A rising edge causes the indexer to advance one step; internal pulldown resistor.
VM	1	15	PWR	Power	Power supply. Connect to motor supply voltage and bypass to PGND with a 0.01- $\mu$ F ceramic capacitor plus a bulk capacitor rated for VM.
nSLEEP	16	14	I	Input	Sleep mode input. Logic high to enable device; logic low to enter low-power sleep mode; internal pulldown resistor. An nSLEEP low pulse clears faults.
PAD	-	-	-	-	Thermal pad. Connect to system ground.

## 6 Specifications

### 6.1 Absolute Maximum Ratings

over operating free-air temperature range (unless otherwise noted)<sup>(1)</sup>

	MIN	MAX	UNIT
Power supply voltage (VM)	-0.3	35	V
nSLEEP pin voltage (nSLEEP)	-0.3	V <sub>VM</sub>	V
Internal regulator voltage (DVDD)	-0.3	5.75	V
Control pin voltage (STEP, DIR, EN/nFAULT, DECAY/TOFF, M0, M1)	-0.3	5.75	V
Open drain output current (EN/nFAULT)	0	10	mA
Reference input pin voltage (VREF)	-0.3	5.75	V
Continuous phase node pin voltage (AOUT1, AOUT2, BOUT1, BOUT2)	-1	V <sub>VM</sub> + 1	V
Transient 100 ns phase node pin voltage (AOUT1, AOUT2, BOUT1, BOUT2)	-3	V <sub>VM</sub> + 3	V
Peak drive current (AOUT1, AOUT2, BOUT1, BOUT2)	Internally Limited		A
Operating ambient temperature, T <sub>A</sub>	-40	125	°C
Operating junction temperature, T <sub>J</sub>	-40	150	°C
Storage temperature, T <sub>stg</sub>	-65	150	°C

(1) Stresses beyond those listed under *Absolute Maximum Ratings* may cause permanent damage to the device. These are stress ratings only, which do not imply functional operation of the device at these or any other conditions beyond those indicated under *Recommended Operating Conditions*. Exposure to absolute-maximum-rated conditions for extended periods may affect device reliability.

### 6.2 ESD Ratings

			VALUE	UNIT	
V <sub>(ESD)</sub>	Electrostatic discharge	Human-body model (HBM), per ANSI/ESDA/JEDEC JS-001	±2000	V	
		Charged-device model (CDM), per JEDEC specification JESD22-C101	Corner pins for PWP (1, 8, 9, and 16)		±750
			Other pins		±500

### 6.3 Recommended Operating Conditions

over operating free-air temperature range (unless otherwise noted)

		MIN	MAX	UNIT
$V_{VM}$	Supply voltage range for normal (DC) operation	4.2	33	V
$V_I$	Logic level input voltage	0	5.5	V
$V_{VREF}$	VREF voltage	0.05	3	V
$f_{PWM}$	Applied STEP signal (STEP)	0	500 <sup>(1)</sup>	kHz
$I_{FS}$	Motor full-scale current (xOUTx)	0	1 <sup>(2)</sup>	A
$I_{rms}$	Motor RMS current (xOUTx)	0	0.7 <sup>(2)</sup>	A
$T_A$	Operating ambient temperature	-40	125	°C
$T_J$	Operating junction temperature	-40	150	°C

- (1) STEP input can operate up to 500 kHz, but system bandwidth is limited by the motor load  
(2) Power dissipation and thermal limits must be observed

### 6.4 Thermal Information

THERMAL METRIC <sup>(1)</sup>		DRV8428		UNIT
		PWP (HTSSOP)	RTE (WQFN)	
		16 PINS	16 PINS	
$R_{\theta JA}$	Junction-to-ambient thermal resistance	46.4	47	°C/W
$R_{\theta JC(top)}$	Junction-to-case (top) thermal resistance	39.8	46.1	°C/W
$R_{\theta JB}$	Junction-to-board thermal resistance	19.9	19.9	°C/W
$\psi_{JT}$	Junction-to-top characterization parameter	1.3	1.1	°C/W
$\psi_{JB}$	Junction-to-board characterization parameter	19.9	19.8	°C/W
$R_{\theta JC(bot)}$	Junction-to-case (bottom) thermal resistance	6.3	8.5	°C/W

- (1) For more information about traditional and new thermal metrics, see the [Semiconductor and IC Package Thermal Metrics application report](#).

## 6.5 Electrical Characteristics

Typical values are at  $T_A = 25^\circ\text{C}$  and  $V_{VM} = 24\text{ V}$ . All limits are over recommended operating conditions, unless otherwise noted.

PARAMETER		TEST CONDITIONS	MIN	TYP	MAX	UNIT
<b>POWER SUPPLIES (VM, DVDD)</b>						
$I_{VM}$	VM operating supply current	EN/nFAULT = 1, nSLEEP = 1, No motor load		3.8	5.6	mA
$I_{VMQ}$	VM sleep mode supply current	nSLEEP = 0		2	4	$\mu\text{A}$
$t_{SLEEP}$	Sleep time	nSLEEP = 0 to sleep-mode	120			$\mu\text{s}$
$t_{WAKE}$	Wake-up time	nSLEEP = 1 to output transition		0.8	1.2	ms
$t_{ON}$	Turn-on time	VM > UVLO to output transition		0.8	1.2	ms
$V_{DVDD}$	Internal regulator voltage	No external load, $6\text{ V} < V_{VM} < 33\text{ V}$	4.75	5	5.25	V
		No external load, $V_{VM} = 4.2\text{ V}$	3.9	4.05		V
<b>LOGIC-LEVEL INPUTS (STEP, DIR, nSLEEP)</b>						
$V_{IL}$	Input logic-low voltage		0		0.6	V
$V_{IH}$	Input logic-high voltage		1.5		5.5	V
$V_{HYS}$	Input logic hysteresis			150		mV
$I_{IL}$	Input logic-low current	$V_{IN} = 0\text{ V}$	-1		1	$\mu\text{A}$
$I_{IH}$	Input logic-high current	$V_{IN} = 5\text{ V}$			100	$\mu\text{A}$
<b>TRI-LEVEL INPUT (M0)</b>						
$V_{I1}$	Input logic-low voltage	Tied to GND	0		0.6	V
$V_{I2}$	Input Hi-Z voltage	Hi-Z	1.8	2	2.2	V
$V_{I3}$	Input logic-high voltage	Tied to DVDD	2.7		5.5	V
$I_O$	Output pull-up current			10		$\mu\text{A}$
<b>QUAD-LEVEL INPUT (M1)</b>						
$V_{I1}$	Input logic-low voltage	Tied to GND	0		0.6	V
$V_{I2}$		$330\text{k}\Omega \pm 5\%$ to GND	1	1.25	1.4	V
$V_{I3}$	Input Hi-Z voltage	Hi-Z	1.8	2	2.2	V
$V_{I4}$	Input logic-high voltage	Tied to DVDD	2.7		5.5	V
$I_{IL}$	Output pull-up current			10		$\mu\text{A}$
<b>SEVEN-LEVEL INPUT (DECAY/TOFF)</b>						
$V_{I1}$	Voltage level 1	Tied to GND	0		0.1	V
$V_{I2}$	Voltage level 2	$14.7\text{k}\Omega \pm 1\%$ to GND	0.2		0.35	V
$V_{I3}$	Voltage level 3	$44.2\text{k}\Omega \pm 1\%$ to GND	0.55		0.8	V
$V_{I4}$	Voltage level 4	$100\text{k}\Omega \pm 1\%$ to GND	1		1.25	V
$V_{I5}$	Voltage level 5	$249\text{k}\Omega \pm 1\%$ to GND	1.5		1.75	V
$V_{I6}$	Voltage level 6	Hi-Z	2.1		2.4	V
$V_{I7}$	Voltage level 7	Tied to DVDD	3		5.5	V
$I_{IL}$	Output pull-up current			22.5		$\mu\text{A}$
<b>CONTROL INPUT/OUTPUT (EN/nFAULT)</b>						
$V_{OL}$	Output Logic-low voltage		0		0.6	V
$R_{PD2}$	Internal Pull-down Resistance			2		M $\Omega$
$I_L$	Leakage current	$V_{EN/nFAULT} = 5\text{ V}$ , FAULT condition			375	$\mu\text{A}$
<b>MOTOR DRIVER OUTPUTS (AOUT1, AOUT2, BOUT1, BOUT2)</b>						
$R_{DS(ONH)}$	High-side FET on resistance	$V_{VM} = 24\text{ V}$ , $T_J = 25^\circ\text{C}$ , $I_O = -0.5\text{ A}$		750	875	m $\Omega$
		$V_{VM} = 24\text{ V}$ , $T_J = 125^\circ\text{C}$ , $I_O = -0.5\text{ A}$		1130	1350	m $\Omega$
		$V_{VM} = 24\text{ V}$ , $T_J = 150^\circ\text{C}$ , $I_O = -0.5\text{ A}$		1250	1450	m $\Omega$

Typical values are at  $T_A = 25^\circ\text{C}$  and  $V_{VM} = 24\text{ V}$ . All limits are over recommended operating conditions, unless otherwise noted.

PARAMETER		TEST CONDITIONS	MIN	TYP	MAX	UNIT
$R_{DS(ONL)}$	Low-side FET on resistance	$V_{VM} = 24\text{ V}$ , $T_J = 25^\circ\text{C}$ , $I_O = 0.5\text{ A}$		750	875	m $\Omega$
		$V_{VM} = 24\text{ V}$ , $T_J = 125^\circ\text{C}$ , $I_O = 0.5\text{ A}$		1130	1350	m $\Omega$
		$V_{VM} = 24\text{ V}$ , $T_J = 150^\circ\text{C}$ , $I_O = 0.5\text{ A}$		1250	1450	m $\Omega$
$t_{SR}$	Output slew rate	$V_{VM} = 24\text{ V}$ , $I_O = 0.5\text{ A}$ , Between 10% and 90%		240		V/ $\mu\text{s}$
<b>PWM CURRENT CONTROL (VREF)</b>						
$K_V$	Transimpedance gain	$V_{REF} = 3\text{ V}$	2.805	3	3.195	V/A
$t_{OFF}$	PWM off-time, mixed 30% decay	DECAY/TOFF = 14.7 k $\Omega$ to GND		7		$\mu\text{s}$
		DECAY/TOFF = 44.2 k $\Omega$ to GND		16		
		DECAY/TOFF = 100 k $\Omega$ to GND		32		
	PWM off-time, Smart tune dynamic decay	DECAY/TOFF = 249 k $\Omega$ to GND		7		
		DECAY/TOFF = Hi-Z		16		
		DECAY/TOFF = Tied to DVDD		32		
$\Delta I_{TRIP}$	Current trip accuracy	$I_O = 1\text{ A}$ , 10% to 20% current setting	-15		15	%
		$I_O = 1\text{ A}$ , 20% to 67% current setting	-10		10	
		$I_O = 1\text{ A}$ , 68% to 100% current setting	-6		6	
$I_{O,CH}$	AOUT and BOUT current matching	$I_O = 1\text{ A}$	-2.5		2.5	%
<b>PROTECTION CIRCUITS</b>						
$V_{UVLO}$	VM UVLO lockout	VM falling, UVLO falling	3.8	3.95	4.05	V
		VM rising, UVLO rising	3.9	4.05	4.15	
$V_{UVLO,HYS}$	Undervoltage hysteresis	Rising to falling threshold		100		mV
$I_{OCP}$	Overcurrent protection	Current through any FET	1.7			A
$t_{OCP}$	Overcurrent deglitch time			1.8		$\mu\text{s}$
$t_{RETRY}$	Overcurrent retry time			4		ms
$T_{OTSD}$	Thermal shutdown	Die temperature $T_J$	150	165	180	$^\circ\text{C}$
$T_{HYS\_OTSD}$	Thermal shutdown hysteresis	Die temperature $T_J$		20		$^\circ\text{C}$

## 6.6 Indexer Timing Requirements

Typical limits are at  $T_J = 25^\circ\text{C}$  and  $V_{VM} = 24\text{ V}$ . Over recommended operating conditions unless otherwise noted.

NO.			MIN	MAX	UNIT
1	$f_{STEP}$	Step frequency		500 <sup>(1)</sup>	kHz
2	$t_{WH(STEP)}$	Pulse duration, STEP high	970		ns
3	$t_{WL(STEP)}$	Pulse duration, STEP low	970		ns
4	$t_{SU(DIR, Mx)}$	Setup time, DIR or MODEx to STEP rising	200		ns
5	$t_{H(DIR, Mx)}$	Hold time, DIR or MODEx to STEP rising	200		ns

(1) STEP input can operate up to 500 kHz, but system bandwidth is limited by the motor load.

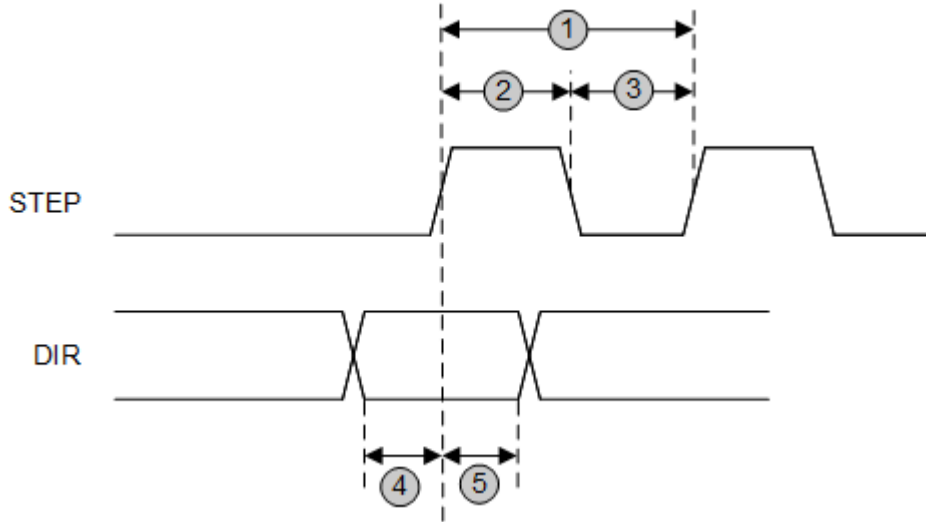

Figure 6-1. STEP and DIR Timing Diagram

### 6.7 Typical Characteristics

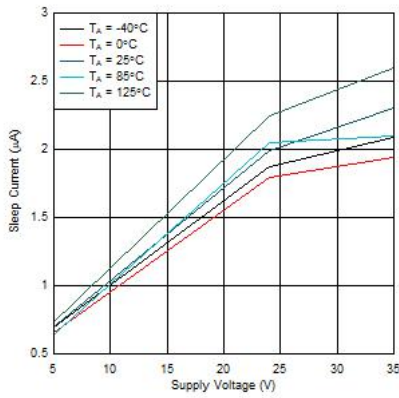

Figure 6-2. Sleep Current over Supply Voltage

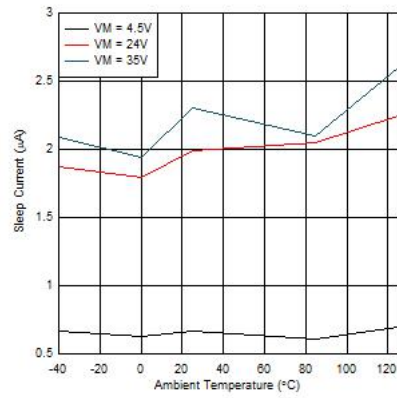

Figure 6-3. Sleep Current over Temperature

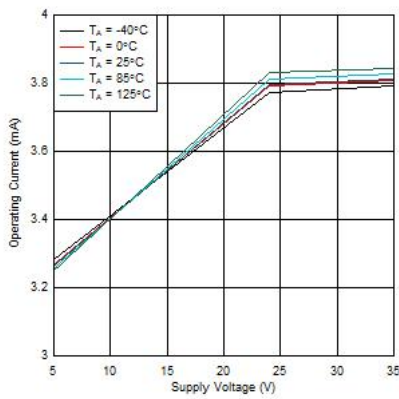

Figure 6-4. Operating Current over Supply Voltage

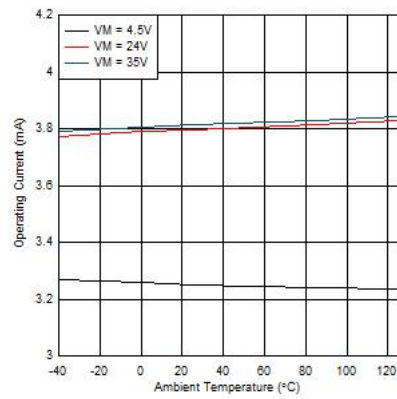

Figure 6-5. Operating Current over Temperature

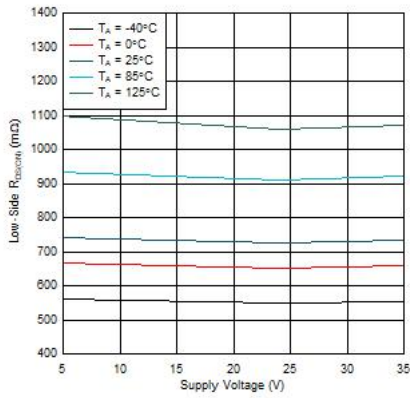

Figure 6-6. Low-Side  $R_{DS(ON)}$  over Supply Voltage

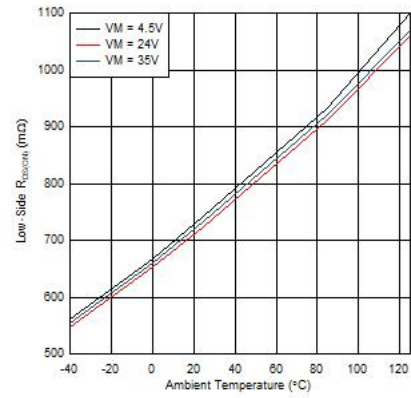

Figure 6-7. Low-Side  $R_{DS(ON)}$  over Temperature

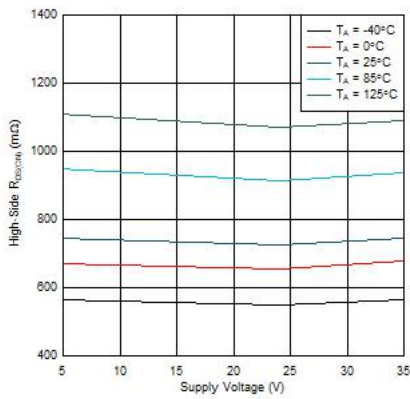

Figure 6-8. High-Side  $R_{DS(ON)}$  over Supply Voltage

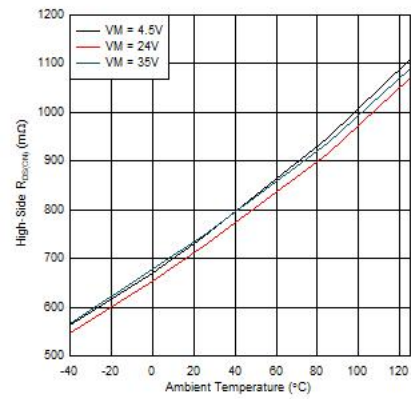

Figure 6-9. High-Side  $R_{DS(ON)}$  over Temperature

## 7 Detailed Description

### 7.1 Overview

The DRV8428 device is an integrated motor-driver solution for bipolar stepper motors. The device provides the maximum integration by integrating two N-channel power MOSFET H-bridges, current sense resistors and regulation circuitry, and a microstepping indexer. The DRV8428 is capable of supporting wide supply voltage range of 4.2 V to 33 V. DRV8428 provides an output current up to 1.7-A peak, 1-A full-scale, or 0.7-A root mean square (rms). The actual full-scale and rms current depends on the ambient temperature, supply voltage, and PCB thermal capability.

The DRV8428 uses an integrated current-sense architecture which eliminates the need for two external power sense resistors, hence saving significant board space, BOM cost, design efforts and reduces significant power consumption. This architecture removes the power dissipated in the sense resistors by using a current mirror approach and using the internal power MOSFETs for current sensing. The current regulation set point is adjusted by the voltage at the VREF pin.

A simple STEP/DIR interface allows for an external controller to manage the direction and step rate of the stepper motor. The internal microstepping indexer can execute high-accuracy micro-stepping without requiring the external controller to manage the winding current level. The indexer is capable of full step, half step, and 1/4, 1/8, 1/16, 1/32, 1/64, 1/128, and 1/256 microstepping. High microstepping contributes to significant audible noise reduction and smooth motion. In addition to a standard half stepping mode, a noncircular half stepping mode is available for increased torque output at higher motor RPM.

Stepper motor drivers need to re-circulate the winding current by implementing several types of decay modes. The DRV8428 comes with smart tune decay modes. The smart tune is an innovative decay mechanism that automatically adjusts for optimal current regulation performance agnostic of voltage, motor speed, variation and aging effects. Smart tune Ripple Control uses a variable off-time, ripple current control scheme to minimize distortion of the motor winding current. Smart tune Dynamic Decay uses a fixed off-time, dynamic fast decay percentage scheme to minimize distortion of the motor winding current while minimizing frequency content and significantly reducing design efforts. Along with this seamless, effortless automatic smart tune, DRV8428 also provides the traditional mixed decay mode.

A low-power sleep mode is included which allows the system to save power when not actively driving the motor.

## 7.2 Functional Block Diagram

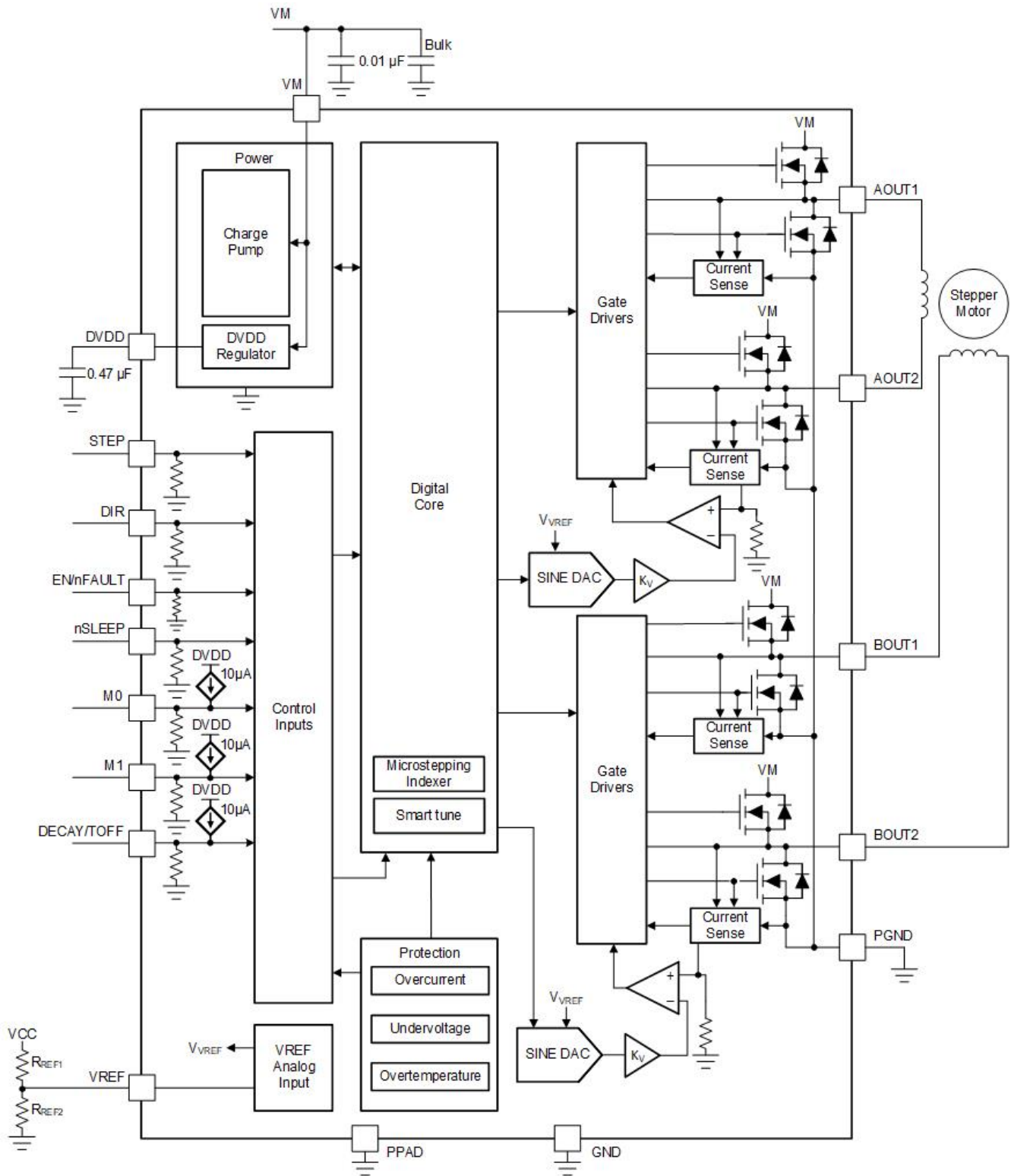

## 7.3 Feature Description

Table 7-1 lists the recommended external components for the DRV8428.

**Table 7-1. DRV8428 External Components**

COMPONENT	PIN 1	PIN 2	RECOMMENDED
C <sub>VM1</sub>	VM	PGND	One X7R, 0.01-μF, VM-rated ceramic capacitor
C <sub>VM2</sub>	VM	PGND	Bulk, VM-rated capacitor
C <sub>DVDD</sub>	DVDD	GND	X7R, 0.47-μF to 1-μF, 6.3-V ceramic capacitor
R <sub>REF1</sub>	VREF	VCC	Resistor to limit chopping current. It is recommended that the value of parallel combination of R <sub>REF1</sub> and R <sub>REF2</sub> should be less than 50-kΩ.
R <sub>REF2</sub> (Optional)	VREF	GND	

### 7.3.1 Stepper Motor Driver Current Ratings

Stepper motor drivers can be classified using three different numbers to describe the output current: peak, RMS, and full-scale.

#### 7.3.1.1 Peak Current Rating

The peak current in a stepper driver is limited by the overcurrent protection trip threshold I<sub>OCP</sub>. The peak current describes any transient duration current pulse, for example when charging capacitance, when the overall duty cycle is very low. In general the minimum value of I<sub>OCP</sub> specifies the peak current rating of the stepper motor driver. For the DRV8428, the peak current rating is 1.7A per bridge.

#### 7.3.1.2 RMS Current Rating

The RMS (average) current is determined by the thermal considerations of the IC. The RMS current is calculated based on the R<sub>DS(ON)</sub>, rise and fall time, PWM frequency, device quiescent current, and package thermal performance in a typical system at 25°C. The actual operating RMS current may be higher or lower depending on heatsinking and ambient temperature. For the DRV8428, the RMS current rating is 0.7 A per bridge.

#### 7.3.1.3 Full-Scale Current Rating

The full-scale current describes the top of the sinusoid current waveform while microstepping. Because the sinusoid amplitude is related to the RMS current, the full-scale current is also determined by the thermal considerations of the device. The full-scale current rating is approximately  $\sqrt{2} \times I_{RMS}$  for a sinusoidal current waveform, and I<sub>RMS</sub> for a square wave current waveform (full step).

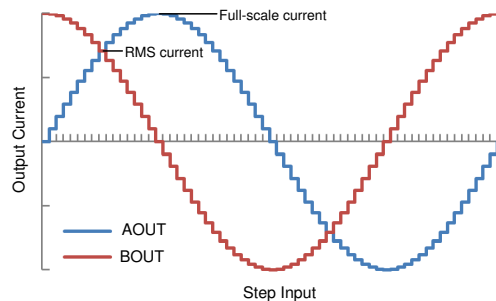

**Figure 7-1. Full-Scale and RMS Current**

### 7.3.2 PWM Motor Drivers

The DRV8428 device has drivers for two full H-bridges to drive the two windings of a bipolar stepper motor. Figure 7-2 shows a block diagram of the circuitry.

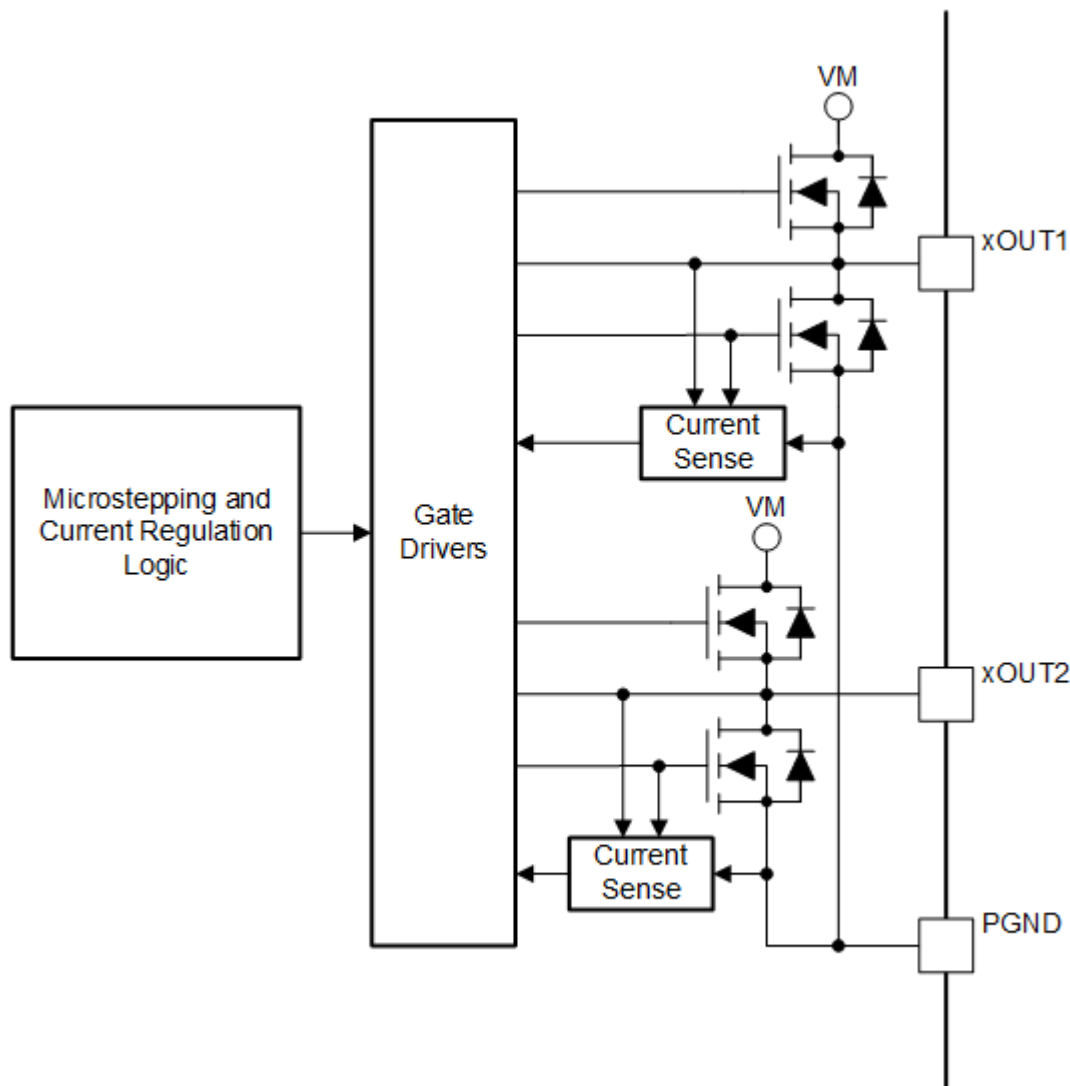

Figure 7-2. PWM Motor Driver Block Diagram

### 7.3.3 Microstepping Indexer

Built-in indexer logic in the DRV8428 allows a number of different step modes. The M0 and M1 pins are used to configure the step mode as shown in Table 7-2. The settings can be changed on the fly.

Table 7-2. Microstepping Settings

M0	M1	STEP MODE
0	0	Full step (2-phase excitation) with 100% current
0	330kΩ to GND	Full step (2-phase excitation) with 71% current
1	0	Non-circular 1/2 step
Hi-Z	0	1/2 step
0	1	1/4 step
1	1	1/8 step

**Table 7-2. Microstepping Settings (continued)**

M0	M1	STEP MODE
Hi-Z	1	1/16 step
0	Hi-Z	1/32 step
Hi-Z	330kΩ to GND	1/64 step
Hi-Z	Hi-Z	1/128 step
1	Hi-Z	1/256 step

Table 7-3 shows the relative current and step directions for full-step (71% current), 1/2 step, 1/4 step and 1/8 step operation. Higher microstepping resolutions follow the same pattern. The AOUT current is the sine of the electrical angle and the BOUT current is the cosine of the electrical angle. Positive current is defined as current flowing from the xOUT1 pin to the xOUT2 pin while driving.

At each rising edge of the STEP input the indexer travels to the next state in the table. The direction is shown with the DIR pin logic high. If the DIR pin is logic low, the sequence is reversed.

**Note**

If the step mode is changed on the fly while stepping, the indexer advances to the next valid state for the new step mode setting at the rising edge of STEP.

The initial excitation state is an electrical angle of 45°, corresponding to 71% of full-scale current in both coils. This state is entered after power-up, after exiting logic undervoltage lockout, or after exiting sleep mode.

**Table 7-3. Relative Current and Step Directions**

1/8 STEP	1/4 STEP	1/2 STEP	FULL STEP 71%	AOUT CURRENT (% FULL-SCALE)	BOUT CURRENT (% FULL-SCALE)	ELECTRICAL ANGLE (DEGREES)
1	1	1		0%	100%	0.00
2				20%	98%	11.25
3	2			38%	92%	22.50
4				56%	83%	33.75
5	3	2	1	71%	71%	45.00
6				83%	56%	56.25
7	4			92%	38%	67.50
8				98%	20%	78.75
9	5	3		100%	0%	90.00
10				98%	-20%	101.25
11	6			92%	-38%	112.50
12				83%	-56%	123.75
13	7	4	2	71%	-71%	135.00
14				56%	-83%	146.25
15	8			38%	-92%	157.50
16				20%	-98%	168.75
17	9	5		0%	-100%	180.00
18				-20%	-98%	191.25
19	10			-38%	-92%	202.50
20				-56%	-83%	213.75
21	11	6	3	-71%	-71%	225.00
22				-83%	-56%	236.25
23	12			-92%	-38%	247.50

**Table 7-3. Relative Current and Step Directions (continued)**

1/8 STEP	1/4 STEP	1/2 STEP	FULL STEP 71%	AOUT CURRENT (% FULL-SCALE)	BOUT CURRENT (% FULL-SCALE)	ELECTRICAL ANGLE (DEGREES)
24				-98%	-20%	258.75
25	13	7		-100%	0%	270.00
26				-98%	20%	281.25
27	14			-92%	38%	292.50
28				-83%	56%	303.75
29	15	8	4	-71%	71%	315.00
30				-56%	83%	326.25
31	16			-38%	92%	337.50
32				-20%	98%	348.75

Table 7-4 shows the full step operation with 100% full-scale current. This stepping mode consumes more power than full-step mode with 71% current, but provides a higher torque at high motor RPM.

**Table 7-4. Full Step with 100% Current**

FULL STEP 100%	AOUT CURRENT (% FULL-SCALE)	BOUT CURRENT (% FULL-SCALE)	ELECTRICAL ANGLE (DEGREES)
1	100	100	45
2	100	-100	135
3	-100	-100	225
4	-100	100	315

Table 7-5 shows the noncircular 1/2-step operation. This stepping mode consumes more power than circular 1/2-step operation, but provides a higher torque at high motor RPM.

**Table 7-5. Non-Circular 1/2-Stepping Current**

NON-CIRCULAR 1/2-STEP	AOUT CURRENT (% FULL-SCALE)	BOUT CURRENT (% FULL-SCALE)	ELECTRICAL ANGLE (DEGREES)
1	0	100	0
2	100	100	45
3	100	0	90
4	100	-100	135
5	0	-100	180
6	-100	-100	225
7	-100	0	270
8	-100	100	315

### 7.3.4 Controlling VREF with an MCU DAC

In some cases, the full-scale output current may need to be changed between many different values, depending on motor speed and loading. The voltage of the VREF pin can be adjusted in the system to change the full-scale current.

In this mode of operation, as the DAC voltage increases, the full-scale regulation current increases as well. For proper operation, the output of the DAC should not rise above 3V.

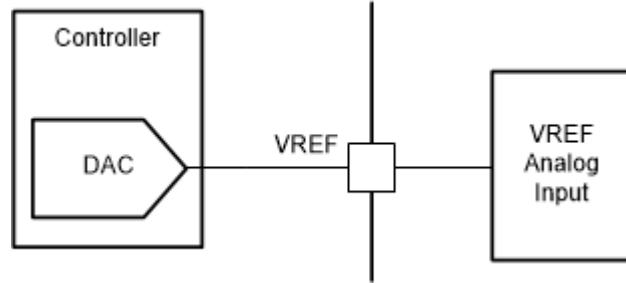

Figure 7-3. Controlling VREF with a DAC Resource

The VREF pin can also be adjusted using a PWM signal and low-pass filter.

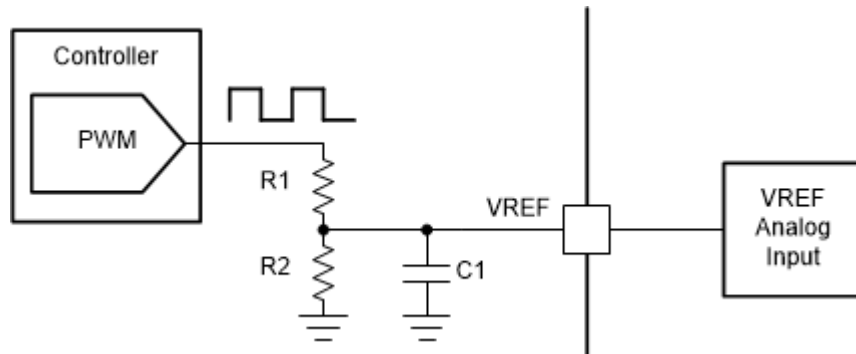

Figure 7-4. Controlling VREF With a PWM Resource

### 7.3.5 Current Regulation, Off-time and Decay Modes

During PWM current chopping, the H-bridge is enabled to drive through the motor winding until the PWM current chopping threshold is reached. This is shown in Figure 7-6, Item 1.

The current through the motor windings is regulated by an adjustable, off-time PWM current-regulation circuit. When an H-bridge is enabled, current rises through the winding at a rate dependent on the DC voltage, inductance of the winding, and the magnitude of the back EMF present. When the current hits the current regulation threshold, the bridge enters a decay mode for a period of time determined by the seven-level DECAY/TOFF pin setting to decrease the current. After the off-time expires, the bridge is re-enabled, starting another PWM cycle.

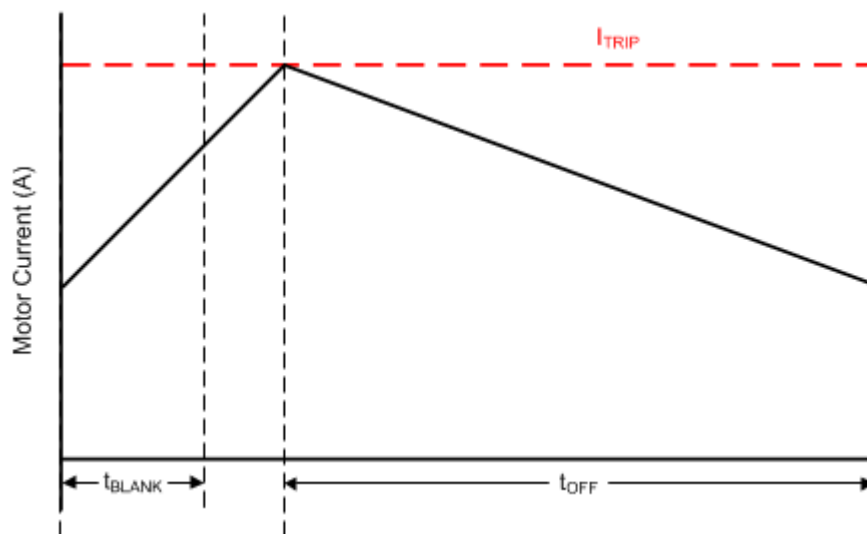
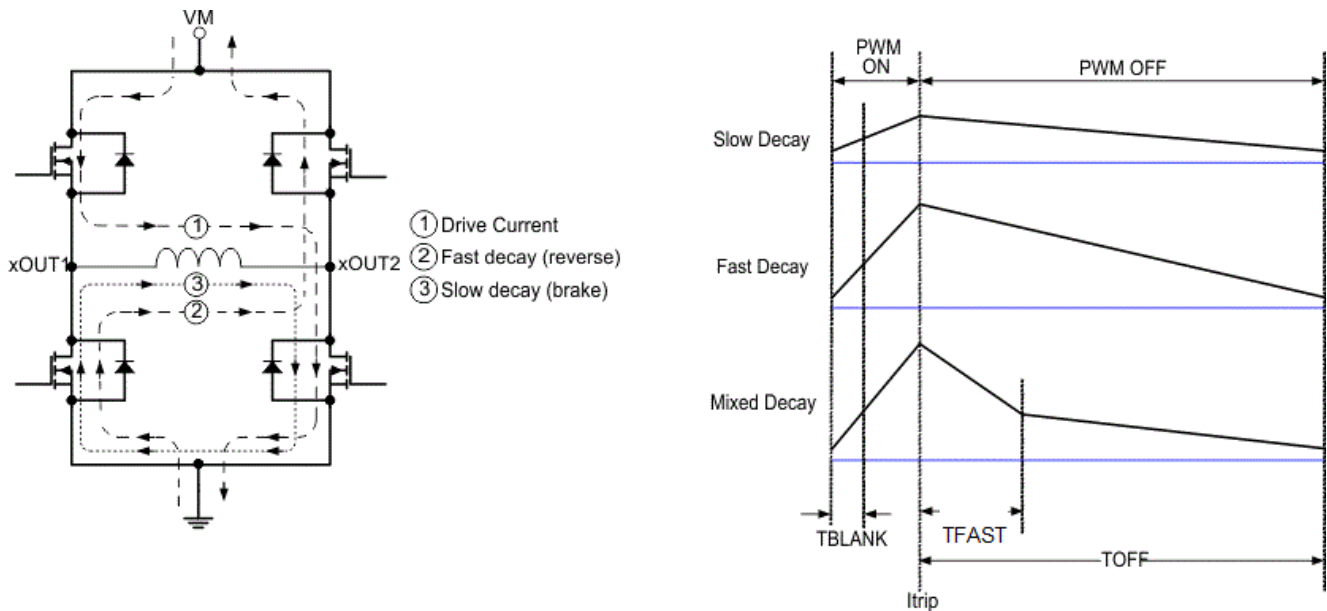

Figure 7-5. Current Chopping Waveform

Once the chopping current threshold is reached, the H-bridge can operate in two different states, fast decay or slow decay. In fast decay mode, once the PWM chopping current level has been reached, the H-bridge reverses state to allow winding current to flow in a reverse direction. The opposite FETs are turned on; as the winding current approaches zero, the bridge is disabled to prevent any reverse current flow. Fast decay mode is shown in [Figure 7-6](#), item 2. In slow decay mode, winding current is re-circulated by enabling both of the low-side FETs in the bridge. This is shown in [Figure 7-6](#), Item 3.

The PWM chopping current is set by a comparator which monitors the voltage across the current sense MOSFETs in parallel with the low-side power MOSFETs. The current sense MOSFETs are biased with a reference current that is the output of a current-mode sine-weighted DAC whose full-scale reference current is set by the voltage at the VREF pin.

The chopping current ( $I_{FS}$ ) can be calculated as  $I_{FS} (A) = V_{REF} (V) / K_V (V/A) = V_{REF} (V) / 3 (V/A)$ .



**Figure 7-6. Decay Modes**

The decay mode and off time for each bridge is selected by setting the seven-level DECAY/TOFF pin as shown in [Table 7-6](#).

**Table 7-6. Decay Mode Settings**

DECAY/TOFF	DECAY MODE	OFF TIME
0	Smart tune Ripple Control	-
14.7kΩ to GND	Mixed 30% Decay	7μs
44.2kΩ to GND		16μs
100kΩ to GND		32μs
249kΩ to GND	Smart tune Dynamic Decay	7μs
Hi-Z		16μs
DVDD		32μs

### 7.3.5.1 Mixed Decay

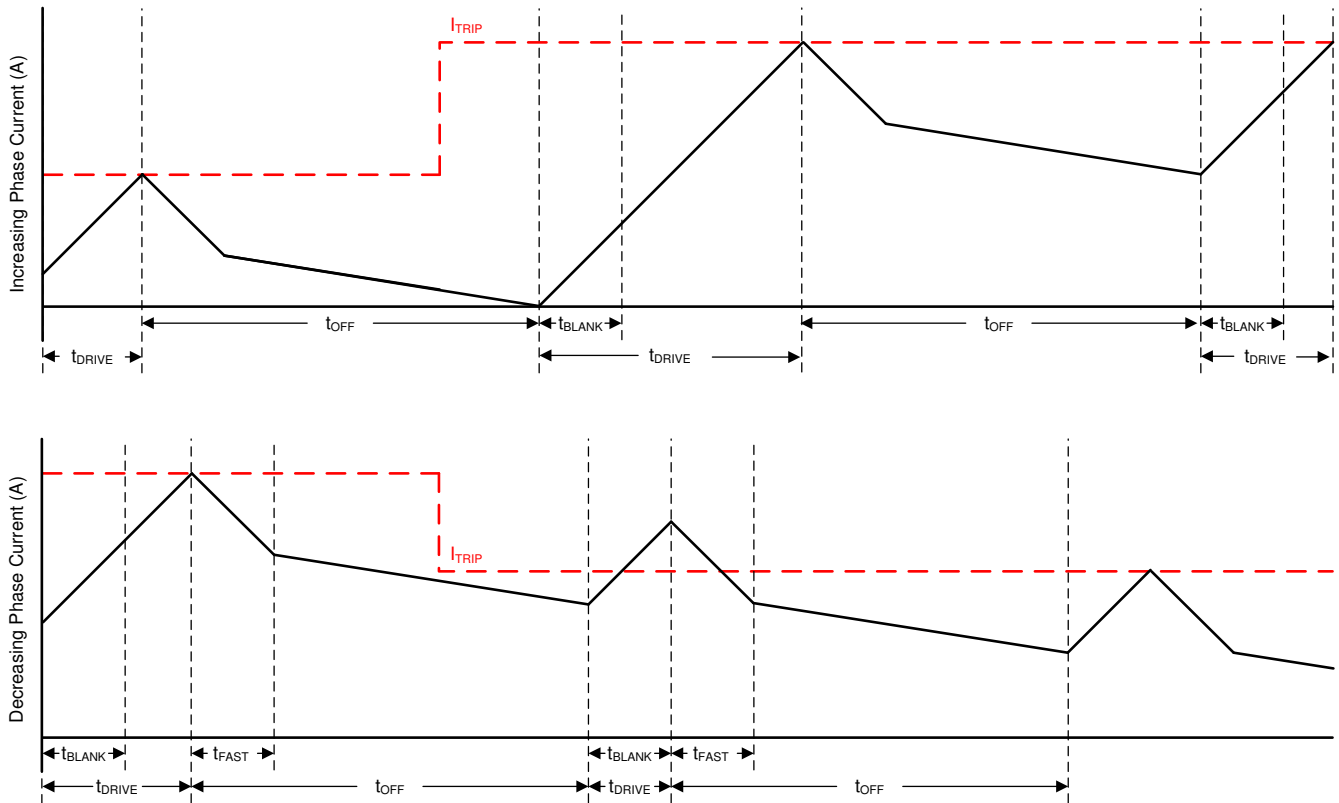

**Figure 7-7. Mixed Decay Mode**

Mixed decay begins as fast decay for 30% of  $t_{OFF}$ , followed by slow decay for the remainder of  $t_{OFF}$ .

### 7.3.5.2 Smart tune Dynamic Decay

The smart tune current regulation scheme is an advanced current-regulation control method compared to traditional fixed off-time current regulation schemes. Smart tune current regulation scheme helps the stepper motor driver adjust the decay scheme based on operating factors such as the ones listed as follows:

- Motor winding resistance and inductance
- Motor aging effects
- Motor dynamic speed and load
- Motor supply voltage variation
- Low-current versus high-current  $di/dt$

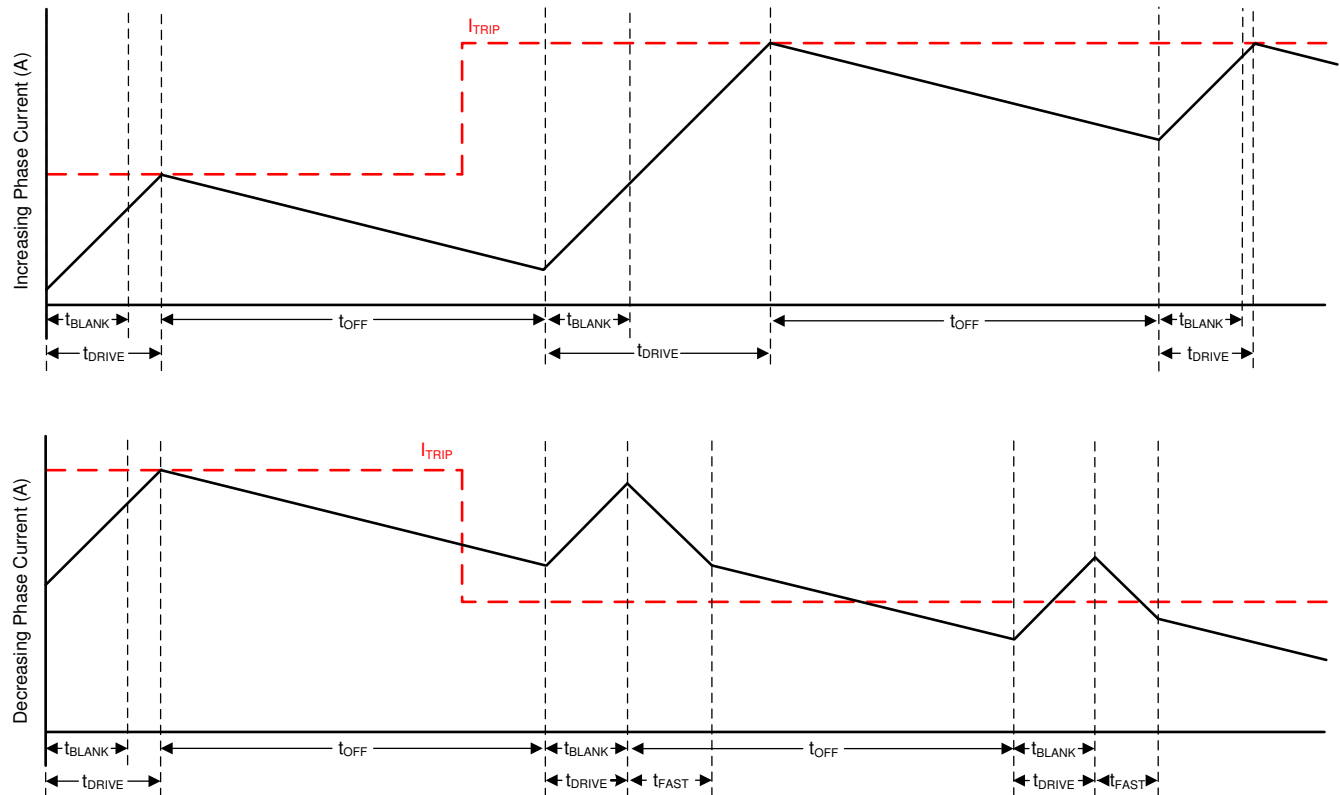

**Figure 7-8. Smart tune Dynamic Decay Mode**

Smart tune Dynamic Decay greatly simplifies the decay mode selection by automatically configuring the decay mode between slow, mixed, and fast decay. In mixed decay, smart tune dynamically adjusts the fast decay percentage of the total mixed decay time. This feature eliminates motor tuning by automatically determining the best decay setting that results in the lowest ripple for the motor.

The decay mode setting is optimized iteratively each PWM cycle. If the motor current overshoots the target trip level, then the decay mode becomes more aggressive (add fast decay percentage) on the next cycle to prevent regulation loss. If a long drive time must occur to reach the target trip level, the decay mode becomes less aggressive (remove fast decay percentage) on the next cycle to operate with less ripple and more efficiently. On falling steps, smart tune Dynamic Decay automatically switches to fast decay to reach the next step quickly.

Smart tune Dynamic Decay is optimal for applications that require minimal current ripple but want to maintain a fixed frequency in the current regulation scheme.

### 7.3.5.3 Smart tune Ripple Control

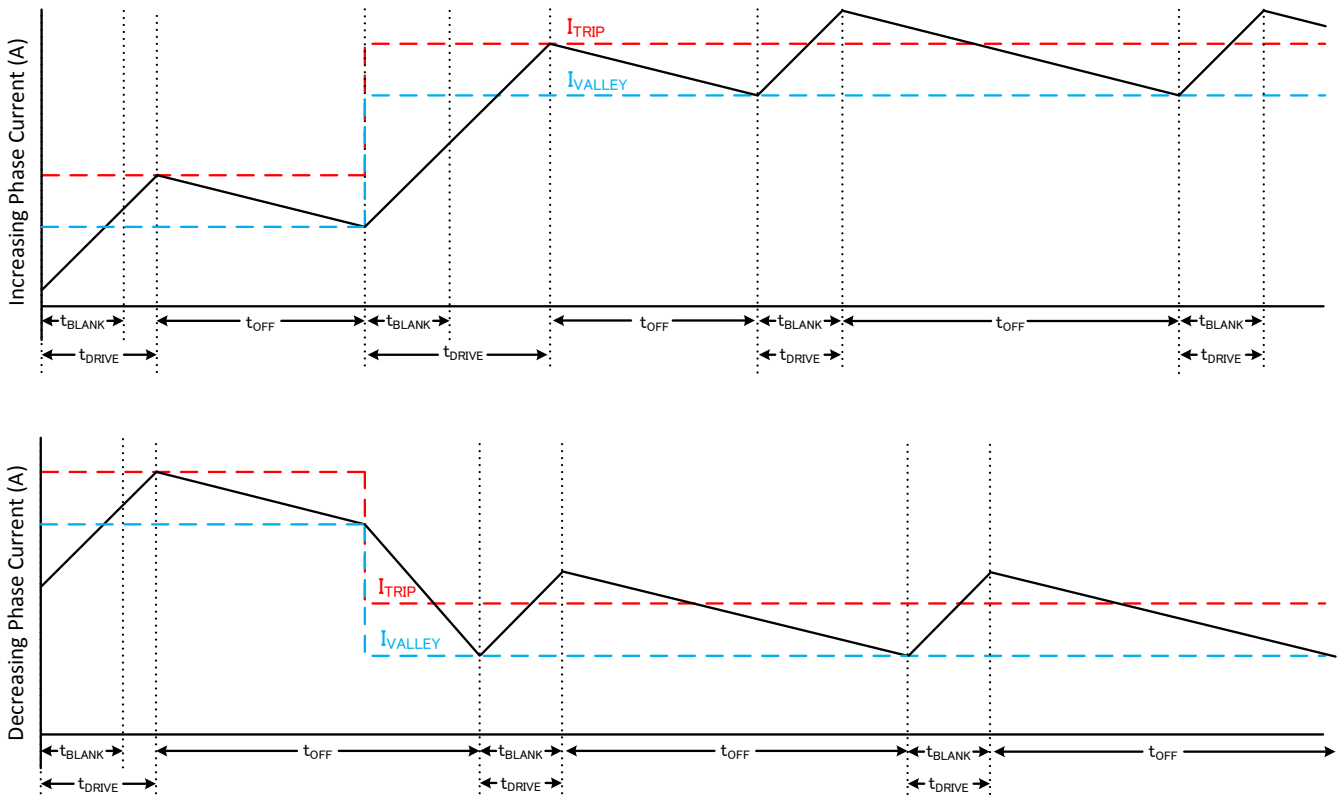

**Figure 7-9. Smart tune Ripple Control Decay Mode**

Smart tune Ripple Control operates by setting an  $I_{VALLEY}$  level alongside the  $I_{TRIP}$  level. When the current level reaches  $I_{TRIP}$ , instead of entering slow decay until the  $t_{OFF}$  time expires, the driver enters slow decay until  $I_{VALLEY}$  is reached. Slow decay operates similar to mode 1 in which both low-side MOSFETs are turned on allowing the current to recirculate. In this mode,  $t_{OFF}$  varies depending on the current level and operating conditions.

This method allows much tighter regulation of the current level increasing motor efficiency and system performance. Smart tune Ripple Control can be used in systems that can tolerate a variable off-time regulation scheme to achieve small current ripple in the current regulation.

The ripple current in this decay mode is  $7.5\text{mA} + 1\%$  of the  $I_{TRIP}$  at a specific microstep level.

#### 7.3.5.4 Blanking time

After the current is enabled (start of drive phase) in an H-bridge, the current sense comparator is ignored for a period of time ( $t_{BLANK}$ ) before enabling the current-sense circuitry. The blanking time also sets the minimum drive time of the PWM. The blanking time is approximately  $1\ \mu\text{s}$ .

### 7.3.6 Linear Voltage Regulators

A linear voltage regulator is integrated in the DRV8428. The DVDD regulator can be used to provide a reference voltage. DVDD can supply a maximum of 2mA load. For proper operation, bypass the DVDD pin to GND using a ceramic capacitor.

The DVDD output is nominally 5-V. When the DVDD LDO current load exceeds 2mA, the output voltage drops significantly.

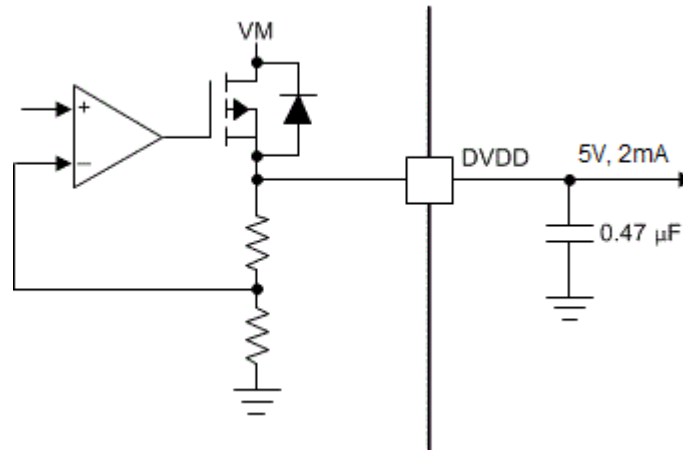

**Figure 7-10. Linear Voltage Regulator Block Diagram**

If a digital input must be tied permanently high (that is, M0, M1 or DECAY/TOFF), tying the input to the DVDD pin instead of an external regulator is preferred. This method saves power when the VM pin is not applied or in sleep mode: the DVDD regulator is disabled and current does not flow through the input pulldown resistors. For reference, logic level inputs have a typical pulldown of 200 kΩ.

The nSLEEP pin cannot be tied to DVDD, else the device will never exit sleep mode.

### 7.3.7 Logic Level, tri-level, quad-level and seven-level Pin Diagrams

Figure 7-11 shows the input structure for M0 pin.

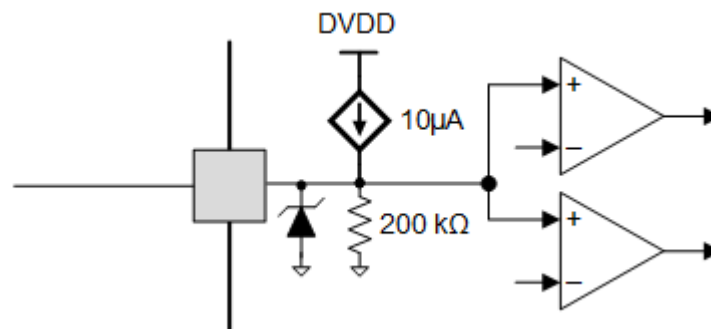

**Figure 7-11. Tri-Level Input Pin Diagram**

Figure 7-12 shows the input structure for M1 pin.

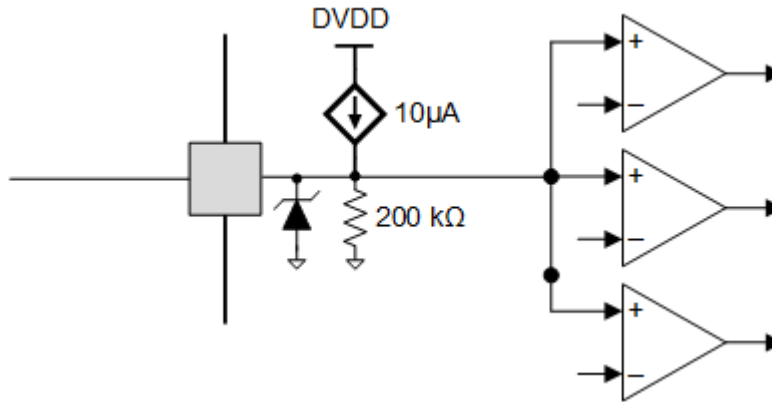

**Figure 7-12. Quad-Level Input Pin Diagram**

Figure 7-13 shows the input structure for STEP, DIR and nSLEEP pins.

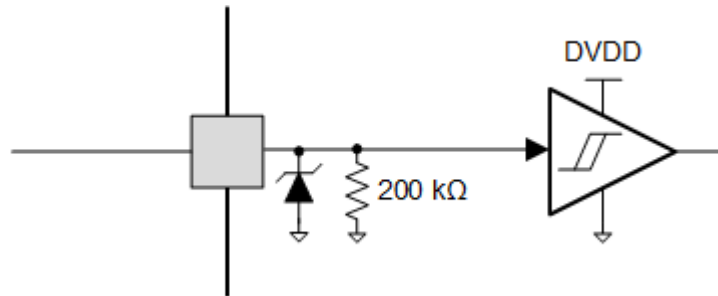

**Figure 7-13. Logic-Level Input Pin Diagram**

Figure 7-14 shows the input structure for DECAY/TOFF pin.

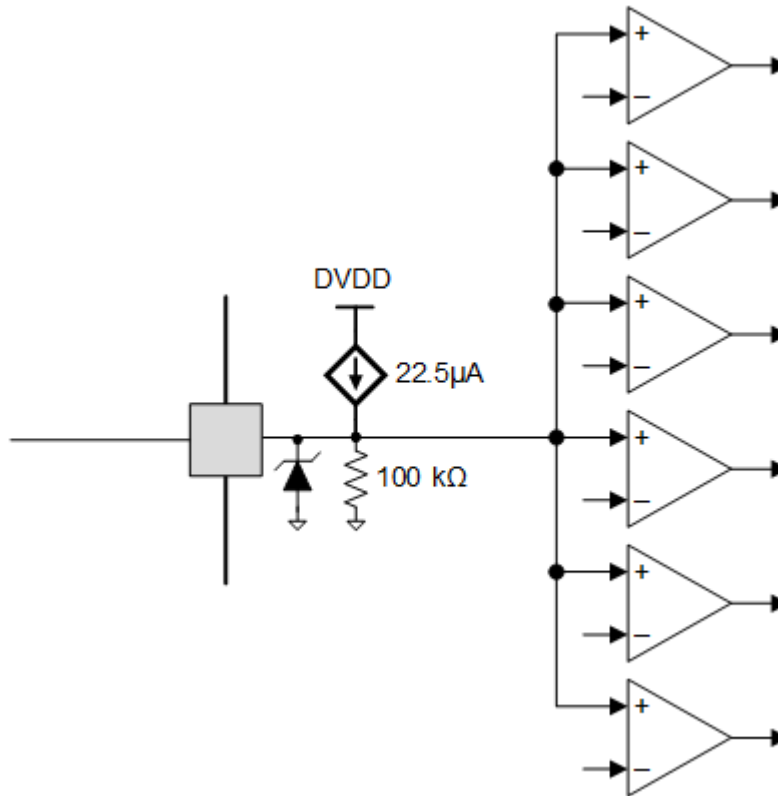

**Figure 7-14. Seven-Level Input Pin Diagram**

### 7.3.7.1 EN/nFAULT Pin

The EN/nFAULT pin is used to enable the driver and also used for fault reporting. [Figure 7-15](#) shows the internal circuitry connected to the EN/nFAULT pin. When the pin is intended to be used for both enabling the driver and fault reporting, the external R-C has to be connected. When the pin is only intended for enabling and disabling the driver, the R-C is not required.

To enable the H-bridges, the pin must be driven high. Floating the pin or connecting the pin to ground forces the bridge to become high-Z.

When a fault is detected, EN/nFAULT pin is forced low by turning on Q1 - which discharges the capacitor C1. The H-bridges are disabled when the voltage on the EN/nFAULT pin falls below the  $V_{IL}$  threshold. The bridges stay disabled till the fault condition is removed or a second MCU pin directly applies a voltage higher than  $V_{IH}$  to the EN/nFAULT pin. Thereafter, Q1 is turned off and C1 charges back through the resistor R1.

The typical delay from EN/nFAULT rising edge to the enabling the H-bridges is 100 $\mu$ s. The time constant of  $R1 * C1$  must be less than 20 $\mu$ s. Typical values of the resistors R2 and R3 are 16 k $\Omega$  and 2 M $\Omega$  respectively. When the EN/nFAULT pin is permanently tied high, a fault will cause additional leakage current due to Q1 being ON.

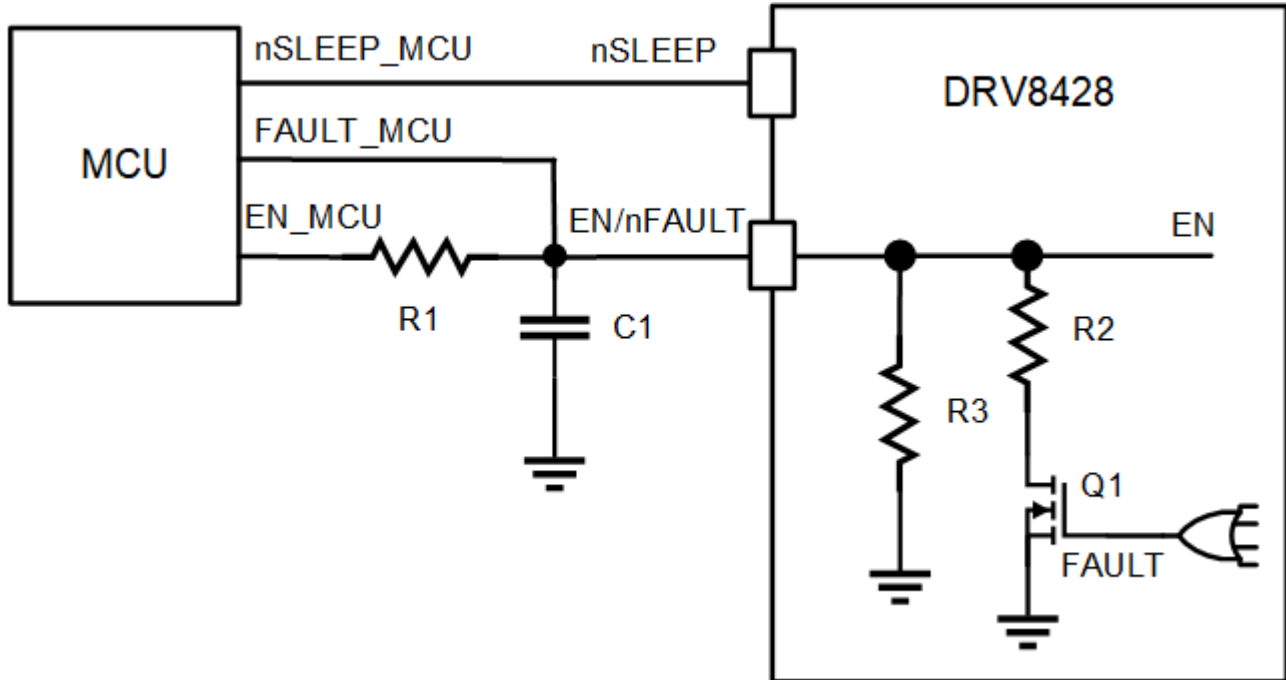

Figure 7-15. EN/nFAULT Pin

### 7.3.8 Protection Circuits

The DRV8428 is fully protected against supply undervoltage, output overcurrent, and device overtemperature events.

#### 7.3.8.1 VM Undervoltage Lockout (UVLO)

If at any time the voltage on the VM pin falls below the UVLO-threshold voltage for the voltage supply, all the outputs are disabled, and the EN/nFAULT pin is driven low. Normal operation resumes (motor-driver operation and EN/nFAULT released) when the VM undervoltage condition is removed.

#### 7.3.8.2 Overcurrent Protection (OCP)

An analog current-limit circuit on each FET limits the current through the FET by removing the gate drive. If this current limit persists for longer than the  $t_{OCP}$  time, the FETs in both H-bridges are disabled and the EN/nFAULT pin is driven low. Normal operation resumes automatically (motor-driver operation and EN/nFAULT released) after the  $t_{RETRY}$  time has elapsed and the fault condition is removed.

#### 7.3.8.3 Thermal Shutdown (OTSD)

If the die temperature exceeds the thermal shutdown limit ( $T_{OTSD}$ ) all MOSFETs in the H-bridge are disabled, and the EN/nFAULT pin is driven low. Normal operation resumes (motor-driver operation and the EN/nFAULT line released) when the junction temperature falls below the overtemperature threshold limit minus the hysteresis ( $T_{OTSD} - T_{HYS\_OTSD}$ ).

#### 7.3.8.4 Fault Condition Summary

Table 7-7. Fault Condition Summary

FAULT	CONDITION	ERROR REPORT	H-BRIDGE	INDEXER	LOGIC	RECOVERY
VM undervoltage (UVLO)	$VM < V_{UVLO}$	EN/nFAULT	Disabled	Disabled	Reset ( $V_{DVDD} < 3.6V$ )	Automatic: $VM > V_{UVLO}$
Overcurrent (OCP)	$I_{OUT} > I_{OCP}$	EN/nFAULT	Disabled	Operating	Operating	Automatic retry: $t_{RETRY}$

**Table 7-7. Fault Condition Summary (continued)**

FAULT	CONDITION	ERROR REPORT	H-BRIDGE	INDEXER	LOGIC	RECOVERY
Thermal Shutdown (OTSD)	$T_J > T_{TSD}$	EN/nFAULT	Disabled	Operating	Operating	Automatic: $T_J < T_{OTSD} - T_{HYS\_OTSD}$

## 7.4 Device Functional Modes

### 7.4.1 Sleep Mode (nSLEEP = 0)

The DRV8428 state is managed by the nSLEEP pin. When the nSLEEP pin is low, the DRV8428 enters a low-power sleep mode. In sleep mode, all the internal MOSFETs are disabled. The  $t_{SLEEP}$  time must elapse after a falling edge on the nSLEEP pin before the device enters sleep mode. The device is brought out of sleep automatically if the nSLEEP pin is brought high. The  $t_{WAKE}$  time must elapse before the device is ready for inputs.

### 7.4.2 Disable Mode (nSLEEP = 1, EN/nFAULT = 0/Hi-Z)

The EN/nFAULT pin is used to enable or disable the DRV8428. When the EN/nFAULT pin is low or floating, the output drivers are disabled in the Hi-Z state.

### 7.4.3 Operating Mode (nSLEEP = 1, EN/nFAULT = 1)

When the nSLEEP pin is high, the EN/nFAULT pin is 1, and  $VM > UVLO$ , the device enters the active mode. The  $t_{WAKE}$  time must elapse before the device is ready for inputs.

### 7.4.4 Functional Modes Summary

Table 7-8 lists a summary of the functional modes.

**Table 7-8. Functional Modes Summary**

CONDITION		CONFIGURATION	H-BRIDGE	DVDD Regulator	INDEXER	Logic
Sleep mode	$4.2\text{ V} < VM < 33\text{ V}$	nSLEEP pin = 0	Disabled	Disabled	Disabled	Disabled
Operating	$4.2\text{ V} < VM < 33\text{ V}$	nSLEEP pin = 1 EN/nFAULT pin = 1	Operating	Operating	Operating	Operating
Disabled	$4.2\text{ V} < VM < 33\text{ V}$	nSLEEP pin = 1 EN/nFAULT pin = 0 or Hi-Z	Disabled	Operating	Operating	Operating

## 8 Application and Implementation

### Note

Information in the following applications sections is not part of the TI component specification, and TI does not warrant its accuracy or completeness. TI's customers are responsible for determining suitability of components for their purposes. Customers should validate and test their design implementation to confirm system functionality.

### 8.1 Application Information

The DRV8428 is used in bipolar stepper motor control.

### 8.2 Typical Application

The following design procedure can be used to configure the DRV8428.

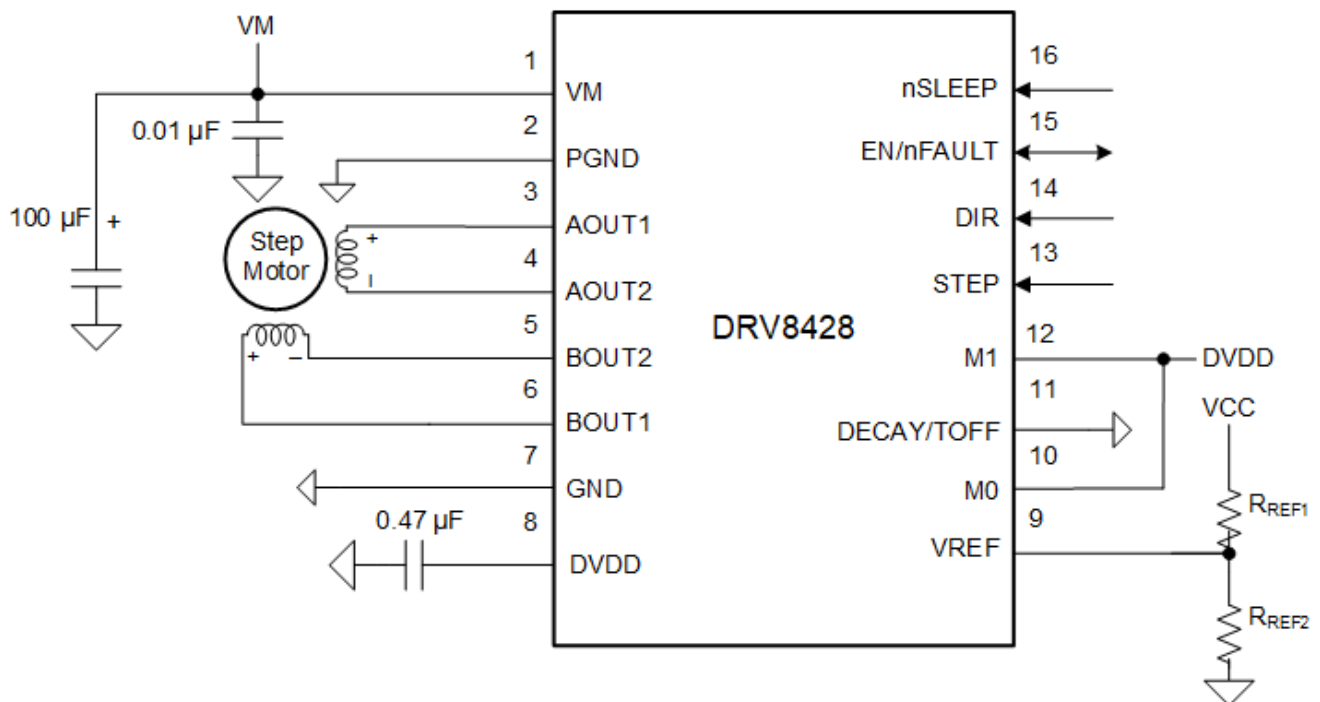

**Figure 8-1. Typical Application Schematic (1/8 microstepping, smart tune Ripple Control Decay, HTSSOP package)**



**Table 8-1. Design Parameters (continued)**

DESIGN PARAMETER	REFERENCE	EXAMPLE VALUE
Target motor speed	v	18.75 rpm
Target full-scale current	I <sub>FS</sub>	500 mA

## 8.2.2 Detailed Design Procedure

### 8.2.2.1 Stepper Motor Speed

The first step in configuring the DRV8428 requires the desired motor speed and microstepping level. If the target application requires a constant speed, then a square wave with frequency  $f_{\text{step}}$  must be applied to the STEP pin. If the target motor speed is too high, the motor does not spin. Make sure that the motor can support the target speed. Use Equation 1 to calculate  $f_{\text{step}}$  for a desired motor speed (v), microstepping level ( $n_m$ ), and motor full step angle ( $\theta_{\text{step}}$ )

$$f_{\text{step}} \text{ (steps / s)} = \frac{v \text{ (rpm)} \times 360 \text{ (}^\circ \text{ / rot)}}{\theta_{\text{step}} \text{ (}^\circ \text{ / step)} \times n_m \text{ (steps / microstep)} \times 60 \text{ (s / min)}} \quad (1)$$

The value of  $\theta_{\text{step}}$  can be found in the stepper motor data sheet, or written on the motor. For example, the motor in this application is required to rotate at 1.8°/step for a target of 18.75 rpm at 1/8 microstep mode. Using Equation 1,  $f_{\text{step}}$  can be calculated as 500 Hz.

The microstepping level is set by the M0 and M1 pins and can be any of the settings listed in Table 8-2. Higher microstepping results in a smoother motor motion and less audible noise, but requires a higher  $f_{\text{step}}$  to achieve the same motor speed.

**Table 8-2. Microstepping Indexer Settings**

M0	M1	STEP MODE
0	0	Full step (2-phase excitation) with 100% current
0	330kΩ to GND	Full step (2-phase excitation) with 71% current
1	0	Non-circular 1/2 step
Hi-Z	0	1/2 step
0	1	1/4 step
1	1	1/8 step
Hi-Z	1	1/16 step
0	Hi-Z	1/32 step
Hi-Z	330kΩ to GND	1/64 step
Hi-Z	Hi-Z	1/128 step
1	Hi-Z	1/256 step

### 8.2.2.2 Current Regulation

In a stepper motor, the full-scale current (I<sub>FS</sub>) is the maximum current driven through either winding. This quantity depends on the VREF voltage. The maximum allowable voltage on the VREF pin is 3 V for DRV8428. DVDD can be used to provide VREF through a resistor divider. During stepping, I<sub>FS</sub> defines the current chopping threshold (I<sub>TRIP</sub>) for the maximum current step.  $I_{\text{FS}} \text{ (A)} = V_{\text{REF}} \text{ (V)} / 3 \text{ (V/A)}$

### 8.2.2.3 Decay Modes

The DRV8428 device supports three different decay modes, as shown in Table 7-6. When a motor winding current has hit the current chopping threshold (I<sub>TRIP</sub>), the DRV8428 places the winding in one of the three decay modes for t<sub>OFF</sub>. After t<sub>OFF</sub>, a new drive phase starts.

### 8.2.2.4 Application Curves

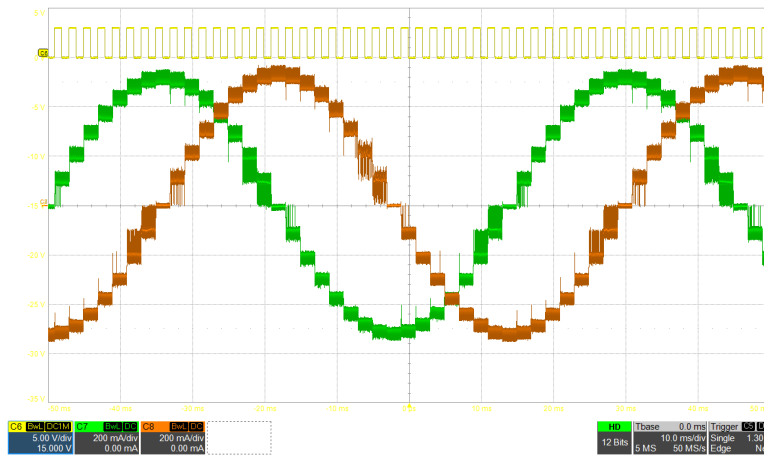

Figure 8-3. 1/8 Microstepping With smart tune Ripple Control Decay



Figure 8-4. 1/8 Microstepping With smart tune Dynamic Decay

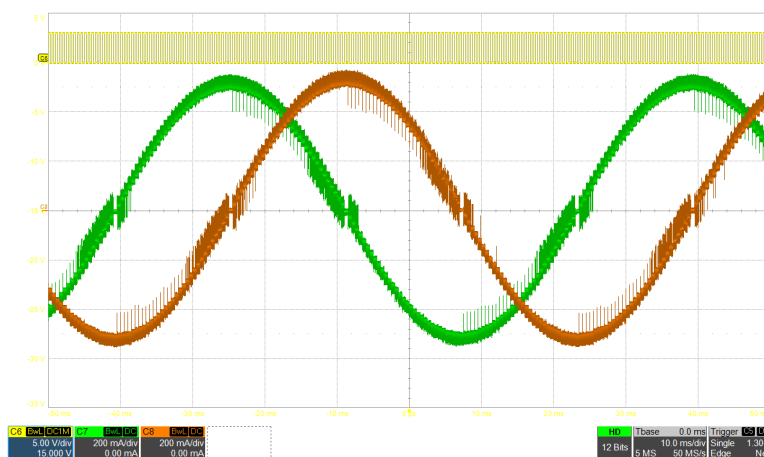
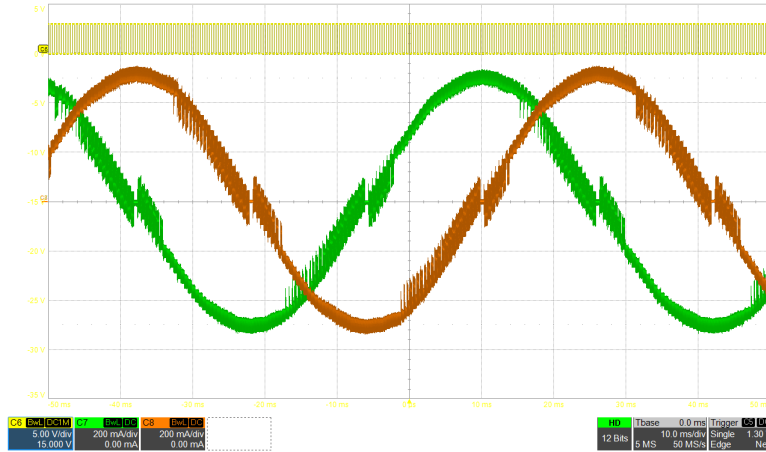
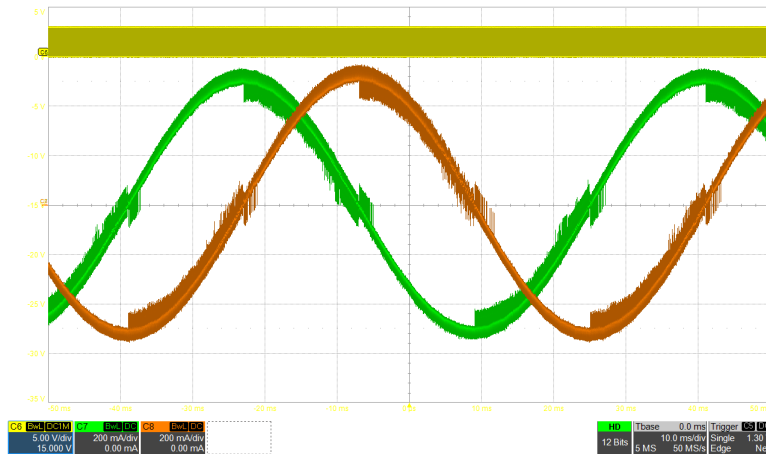

Figure 8-5. 1/32 Microstepping With smart tune Ripple Control Decay



**Figure 8-6. 1/32 Microstepping With smart tune Dynamic Decay**



**Figure 8-7. 1/256 Microstepping With smart tune Ripple Control Decay**

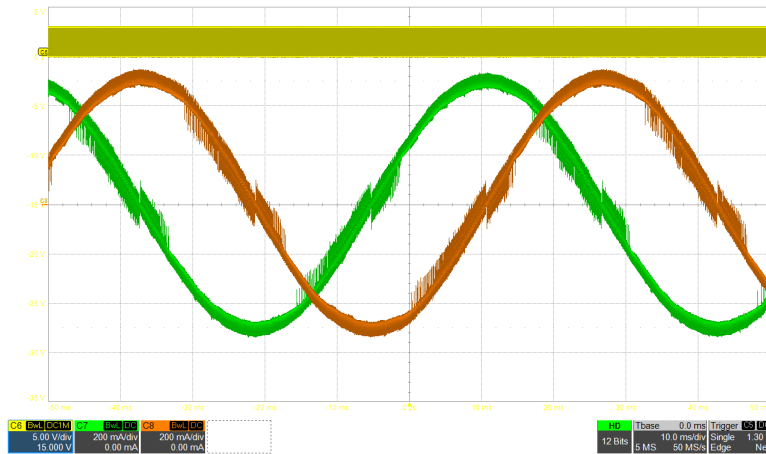

**Figure 8-8. 1/256 Microstepping With smart tune Dynamic Decay**

### 8.2.3 Thermal Application

This section presents the power dissipation calculation and junction temperature estimation of the device.

#### 8.2.3.1 Power Dissipation

The total power dissipation constitutes of three main components - conduction loss ( $P_{COND}$ ), switching loss ( $P_{SW}$ ) and power loss due to quiescent current consumption ( $P_Q$ ).

##### 8.2.3.1.1 Conduction Loss

The current path for a motor connected in full-bridge is through the high-side FET of one half-bridge and low-side FET of the other half-bridge. The conduction loss ( $P_{COND}$ ) depends on the motor rms current ( $I_{RMS}$ ) and high-side ( $R_{DS(ONH)}$ ) and low-side ( $R_{DS(ONL)}$ ) on-state resistances as shown in [Equation 2](#).

$$P_{COND} = 2 \times (I_{RMS})^2 \times (R_{DS(ONH)} + R_{DS(ONL)}) \quad (2)$$

The conduction loss for the typical application shown in [Table 8-2](#) is calculated in [Equation 3](#).

$$P_{COND} = 2 \times (I_{RMS})^2 \times (R_{DS(ONH)} + R_{DS(ONL)}) = 2 \times (0.5-A / \sqrt{2})^2 \times (0.75-\Omega + 0.75-\Omega) = 0.375-W \quad (3)$$

---

#### Note

This power calculation is highly dependent on the device temperature which significantly effects the high-side and low-side on-resistance of the FETs. For more accurate calculation, consider the dependency of on-resistance of FETs with device temperature.

---

##### 8.2.3.1.2 Switching Loss

The power loss due to the PWM switching frequency depends on the slew rate ( $t_{SR}$ ), supply voltage, motor RMS current and the PWM switching frequency. The switching losses in each H-bridge during rise-time and fall-time are calculated as shown in [Equation 4](#) and [Equation 5](#).

$$P_{SW\_RISE} = 0.5 \times V_{VM} \times I_{RMS} \times t_{RISE\_PWM} \times f_{PWM} \quad (4)$$

$$P_{SW\_FALL} = 0.5 \times V_{VM} \times I_{RMS} \times t_{FALL\_PWM} \times f_{PWM} \quad (5)$$

Both  $t_{RISE\_PWM}$  and  $t_{FALL\_PWM}$  can be approximated as  $V_{VM} / t_{SR}$ . After substituting the values of various parameters, and assuming 30-kHz PWM frequency, the switching losses in each H-bridge are calculated as shown below -

$$P_{SW\_RISE} = 0.5 \times 24-V \times (0.5-A / \sqrt{2}) \times (24-V / 240 V/\mu s) \times 30-kHz = 0.013-W \quad (6)$$

$$P_{SW\_FALL} = 0.5 \times 24-V \times (2-A / \sqrt{2}) \times (24-V / 240 V/\mu s) \times 30-kHz = 0.013-W \quad (7)$$

The total switching loss for the stepper motor driver ( $P_{SW}$ ) is calculated as twice the sum of rise-time ( $P_{SW\_RISE}$ ) switching loss and fall-time ( $P_{SW\_FALL}$ ) switching loss as shown below -

$$P_{SW} = 2 \times (P_{SW\_RISE} + P_{SW\_FALL}) = 2 \times (0.013-W + 0.013-W) = 0.052-W \quad (8)$$

---

#### Note

The rise-time ( $t_{RISE}$ ) and the fall-time ( $t_{FALL}$ ) are calculated based on typical values of the slew rate ( $t_{SR}$ ). This parameter is expected to change based on the supply-voltage, temperature and device to device variation.

The switching loss is directly proportional to the PWM switching frequency. The PWM frequency in an application will depend on the supply voltage, inductance of the motor coil, back emf voltage and OFF time or the ripple current (for smart tune ripple control decay mode).

---

### 8.2.3.1.3 Power Dissipation Due to Quiescent Current

The power dissipation due to the quiescent current consumed by the power supply is calculated as shown below -

$$P_Q = V_{VM} \times I_{VM} \quad (9)$$

Substituting the values, quiescent power loss can be calculated as shown below -

$$P_Q = 24\text{-V} \times 3.8\text{-mA} = 0.0912\text{-W} \quad (10)$$

---

#### Note

The quiescent power loss is calculated using the typical operating supply current ( $I_{VM}$ ) which is dependent on supply-voltage, temperature and device to device variation.

---

### 8.2.3.1.4 Total Power Dissipation

The total power dissipation ( $P_{TOT}$ ) is calculated as the sum of conduction loss, switching loss and the quiescent power loss as shown in [Equation 11](#).

$$P_{TOT} = P_{COND} + P_{SW} + P_Q = 0.375\text{-W} + 0.052\text{-W} + 0.0912\text{-W} = 0.5182\text{-W} \quad (11)$$

### 8.2.3.2 Device Junction Temperature Estimation

For an ambient temperature of  $T_A$  and total power dissipation ( $P_{TOT}$ ), the junction temperature ( $T_J$ ) is calculated as  $T_J = T_A + (P_{TOT} \times R_{\theta JA})$

Considering a JEDEC standard 4-layer PCB, the junction-to-ambient thermal resistance ( $R_{\theta JA}$ ) is 46.4 °C/W for the HTSSOP package and 47 °C/W for the WQFN package.

Assuming 25°C ambient temperature, the junction temperature for the HTSSOP package is calculated as shown below -

$$T_J = 25^\circ\text{C} + (0.5182\text{-W} \times 46.4^\circ\text{C/W}) = 49.04^\circ\text{C} \quad (12)$$

The junction temperature for the WQFN package is calculated as shown below -

$$T_J = 25^\circ\text{C} + (0.5182\text{-W} \times 47^\circ\text{C/W}) = 49.35^\circ\text{C} \quad (13)$$

Therefore, the HTSSOP and the WQFN packages result in almost identical junction temperature.

## 9 Power Supply Recommendations

The DRV8428 is designed to operate from an input voltage supply (VM) range from 4.2 V to 33 V. A 0.01- $\mu\text{F}$  ceramic capacitor rated for VM must be placed at each VM pin as close to the DRV8428 as possible. In addition, a bulk capacitor must be included on VM.

### 9.1 Bulk Capacitance

Having appropriate local bulk capacitance is an important factor in motor drive system design. It is generally beneficial to have more bulk capacitance, while the disadvantages are increased cost and physical size.

The amount of local capacitance needed depends on a variety of factors, including:

- The highest current required by the motor system
- The power supply's capacitance and ability to source current
- The amount of parasitic inductance between the power supply and motor system
- The acceptable voltage ripple
- The type of motor used (brushed DC, brushless DC, stepper)
- The motor braking method

The inductance between the power supply and motor drive system will limit the rate current can change from the power supply. If the local bulk capacitance is too small, the system will respond to excessive current demands or dumps from the motor with a change in voltage. When adequate bulk capacitance is used, the motor voltage remains stable and high current can be quickly supplied.

The data sheet generally provides a recommended value, but system-level testing is required to determine the appropriate sized bulk capacitor.

The voltage rating for bulk capacitors should be higher than the operating voltage, to provide margin for cases when the motor transfers energy to the supply.

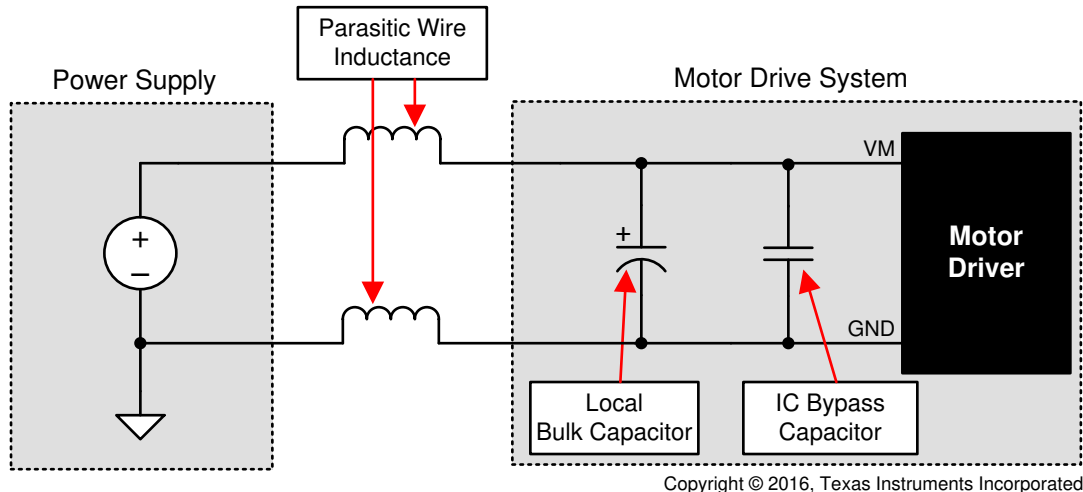

**Figure 9-1. Example Setup of Motor Drive System With External Power Supply**

## 10 Layout

### 10.1 Layout Guidelines

The VM pin should be bypassed to PGND using a low-ESR ceramic bypass capacitor with a recommended value of 0.01  $\mu\text{F}$  rated for VM. This capacitor should be placed as close to the VM pin as possible with a thick trace or ground plane connection to the device PGND pin.

The VM pin must be bypassed to ground using a bulk capacitor rated for VM. This component can be an electrolytic capacitor.

Bypass the DVDD pin to ground with a low-ESR ceramic capacitor. A value of 0.47  $\mu\text{F}$  rated for 6.3 V is recommended. Place this bypassing capacitor as close to the pin as possible.

The thermal PAD must be connected to system ground.

#### 10.1.1 Layout Example

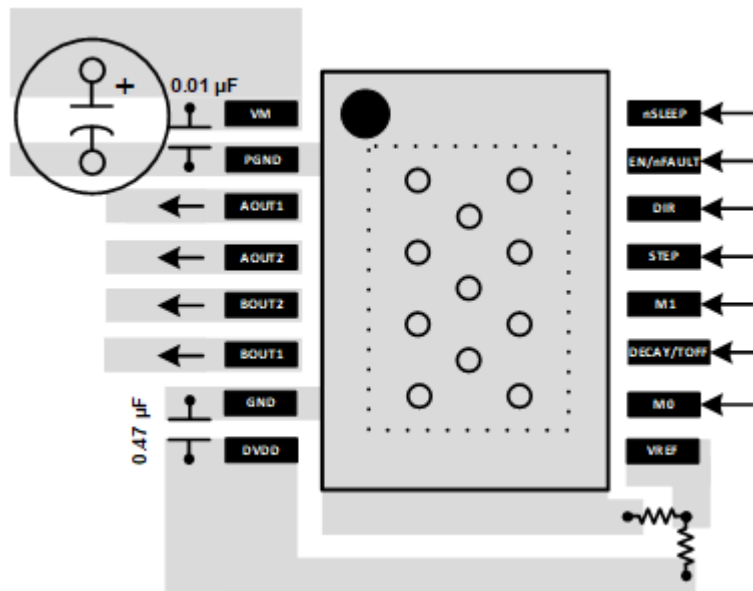

Figure 10-1. HTSSOP Layout Example

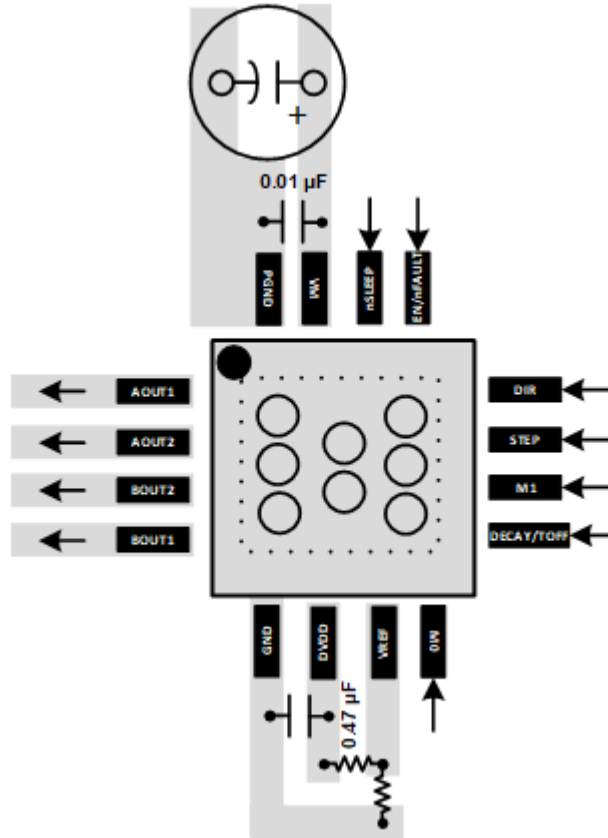

Figure 10-2. WQFN Layout Example

## **11 Device and Documentation Support**

### **11.1 Receiving Notification of Documentation Updates**

To receive notification of documentation updates, navigate to the device product folder on ti.com. In the upper right corner, click on *Alert me* to register and receive a weekly digest of any product information that has changed. For change details, review the revision history included in any revised document.

### **11.2 Community Resources**

### **11.3 Trademarks**

All trademarks are the property of their respective owners.

## 12 Mechanical, Packaging, and Orderable Information

The following pages include mechanical, packaging, and orderable information. This information is the most current data available for the designated devices. This data is subject to change without notice and revision of this document. For browser-based versions of this data sheet, refer to the left-hand navigation.

**PACKAGING INFORMATION**

Orderable Device	Status (1)	Package Type	Package Drawing	Pins	Package Qty	Eco Plan (2)	Lead finish/ Ball material (6)	MSL Peak Temp (3)	Op Temp (°C)	Device Marking (4/5)	Samples
DRV8428PWPR	ACTIVE	HTSSOP	PWP	16	3000	RoHS & Green	NIPDAU	Level-3-260C-168 HR	-40 to 125	8428	<a href="#">Samples</a>
DRV8428RTER	ACTIVE	WQFN	RTE	16	3000	RoHS & Green	NIPDAU	Level-1-260C-UNLIM	-40 to 125	8428	<a href="#">Samples</a>

(1) The marketing status values are defined as follows:

**ACTIVE:** Product device recommended for new designs.

**LIFEBUY:** TI has announced that the device will be discontinued, and a lifetime-buy period is in effect.

**NRND:** Not recommended for new designs. Device is in production to support existing customers, but TI does not recommend using this part in a new design.

**PREVIEW:** Device has been announced but is not in production. Samples may or may not be available.

**OBSOLETE:** TI has discontinued the production of the device.

(2) **RoHS:** TI defines "RoHS" to mean semiconductor products that are compliant with the current EU RoHS requirements for all 10 RoHS substances, including the requirement that RoHS substance do not exceed 0.1% by weight in homogeneous materials. Where designed to be soldered at high temperatures, "RoHS" products are suitable for use in specified lead-free processes. TI may reference these types of products as "Pb-Free".

**RoHS Exempt:** TI defines "RoHS Exempt" to mean products that contain lead but are compliant with EU RoHS pursuant to a specific EU RoHS exemption.

**Green:** TI defines "Green" to mean the content of Chlorine (Cl) and Bromine (Br) based flame retardants meet JS709B low halogen requirements of <=1000ppm threshold. Antimony trioxide based flame retardants must also meet the <=1000ppm threshold requirement.

(3) MSL, Peak Temp. - The Moisture Sensitivity Level rating according to the JEDEC industry standard classifications, and peak solder temperature.

(4) There may be additional marking, which relates to the logo, the lot trace code information, or the environmental category on the device.

(5) Multiple Device Markings will be inside parentheses. Only one Device Marking contained in parentheses and separated by a "~" will appear on a device. If a line is indented then it is a continuation of the previous line and the two combined represent the entire Device Marking for that device.

(6) Lead finish/Ball material - Orderable Devices may have multiple material finish options. Finish options are separated by a vertical ruled line. Lead finish/Ball material values may wrap to two lines if the finish value exceeds the maximum column width.

**Important Information and Disclaimer:**The information provided on this page represents TI's knowledge and belief as of the date that it is provided. TI bases its knowledge and belief on information provided by third parties, and makes no representation or warranty as to the accuracy of such information. Efforts are underway to better integrate information from third parties. TI has taken and continues to take reasonable steps to provide representative and accurate information but may not have conducted destructive testing or chemical analysis on incoming materials and chemicals. TI and TI suppliers consider certain information to be proprietary, and thus CAS numbers and other limited information may not be available for release.

In no event shall TI's liability arising out of such information exceed the total purchase price of the TI part(s) at issue in this document sold by TI to Customer on an annual basis.

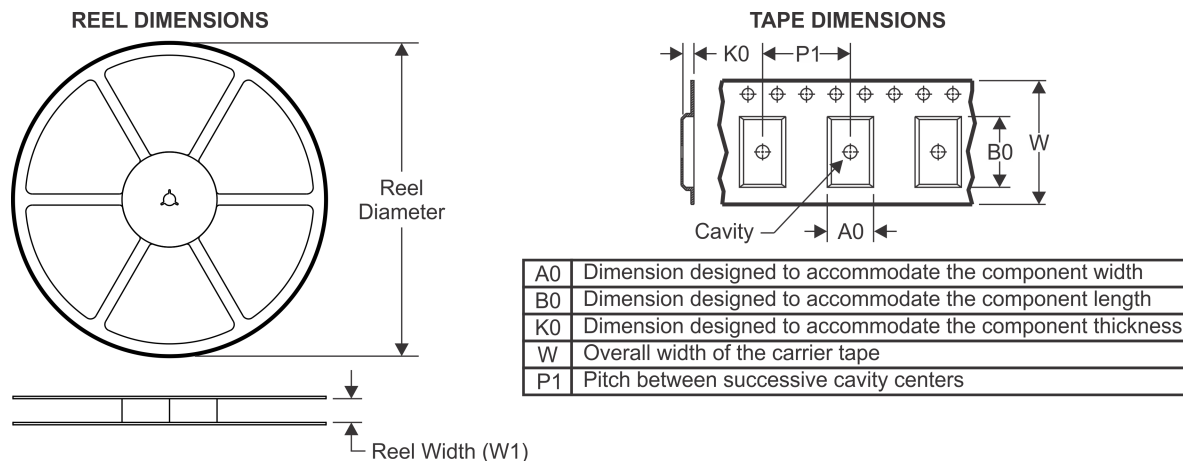
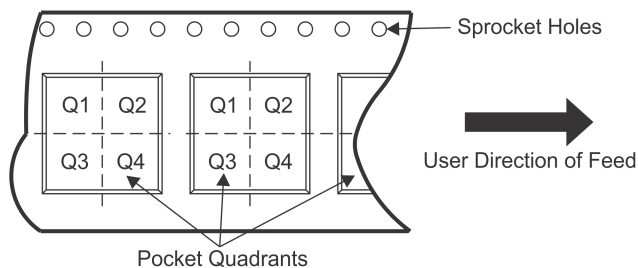

**TAPE AND REEL INFORMATION**

**QUADRANT ASSIGNMENTS FOR PIN 1 ORIENTATION IN TAPE**

\*All dimensions are nominal

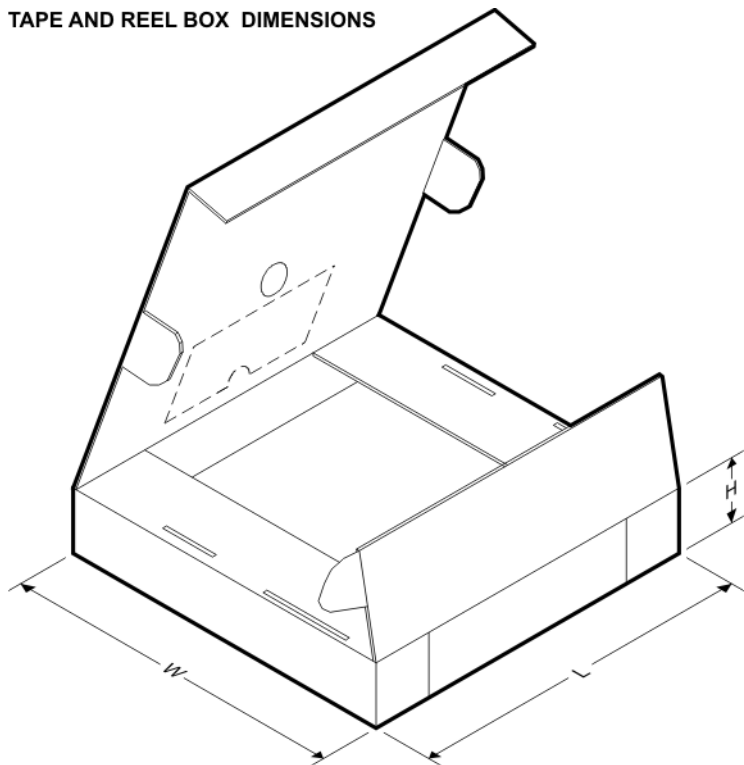
Device	Package Type	Package Drawing	Pins	SPQ	Reel Diameter (mm)	Reel Width W1 (mm)	A0 (mm)	B0 (mm)	K0 (mm)	P1 (mm)	W (mm)	Pin1 Quadrant
DRV8428PWPR	HTSSOP	PWP	16	3000	330.0	12.4	6.9	5.6	1.6	8.0	12.0	Q1
DRV8428RTER	WQFN	RTE	16	3000	330.0	12.4	3.3	3.3	1.1	8.0	12.0	Q2

**TAPE AND REEL BOX DIMENSIONS**

\*All dimensions are nominal

Device	Package Type	Package Drawing	Pins	SPQ	Length (mm)	Width (mm)	Height (mm)
DRV8428PWPR	HTSSOP	PWP	16	3000	853.0	449.0	35.0
DRV8428RTER	WQFN	RTE	16	3000	367.0	367.0	35.0

# MECHANICAL DATA

RTE (S-PWQFN-N16)

PLASTIC QUAD FLATPACK NO-LEAD

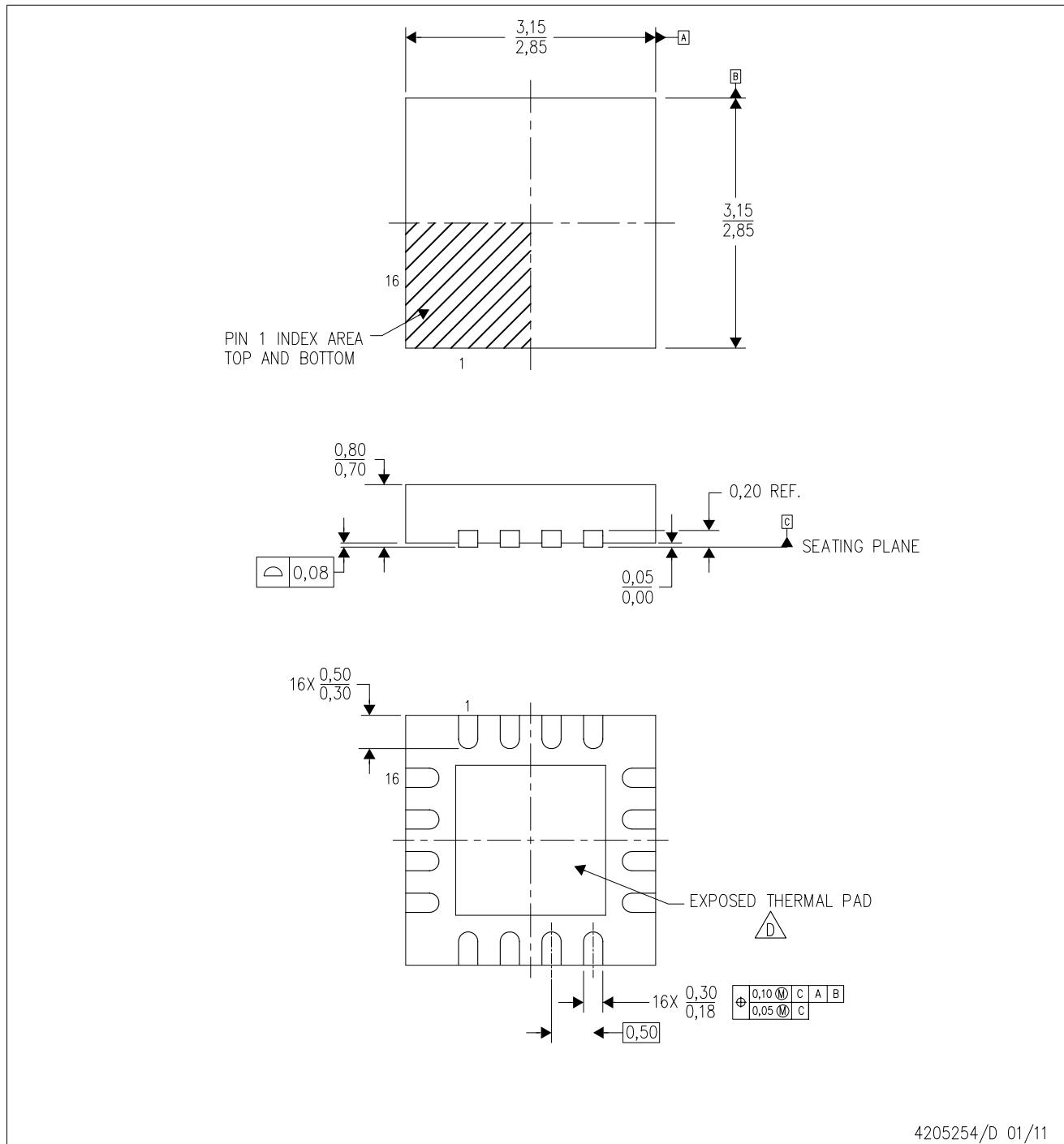

4205254/D 01/11

- NOTES:
- A. All linear dimensions are in millimeters. Dimensioning and tolerancing per ASME Y14.5M-1994.
  - B. This drawing is subject to change without notice.
  - C. Quad Flatpack, No-leads (QFN) package configuration.
  -  The package thermal pad must be soldered to the board for thermal and mechanical performance. See the Product Data Sheet for details regarding the exposed thermal pad dimensions.
  - E. Falls within JEDEC MO-220.

## THERMAL INFORMATION

This package incorporates an exposed thermal pad that is designed to be attached directly to an external heatsink. The thermal pad must be soldered directly to the printed circuit board (PCB). After soldering, the PCB can be used as a heatsink. In addition, through the use of thermal vias, the thermal pad can be attached directly to the appropriate copper plane shown in the electrical schematic for the device, or alternatively, can be attached to a special heatsink structure designed into the PCB. This design optimizes the heat transfer from the integrated circuit (IC).

For information on the Quad Flatpack No-Lead (QFN) package and its advantages, refer to Application Report, QFN/SON PCB Attachment, Texas Instruments Literature No. SLUA271. This document is available at [www.ti.com](http://www.ti.com).

The exposed thermal pad dimensions for this package are shown in the following illustration.

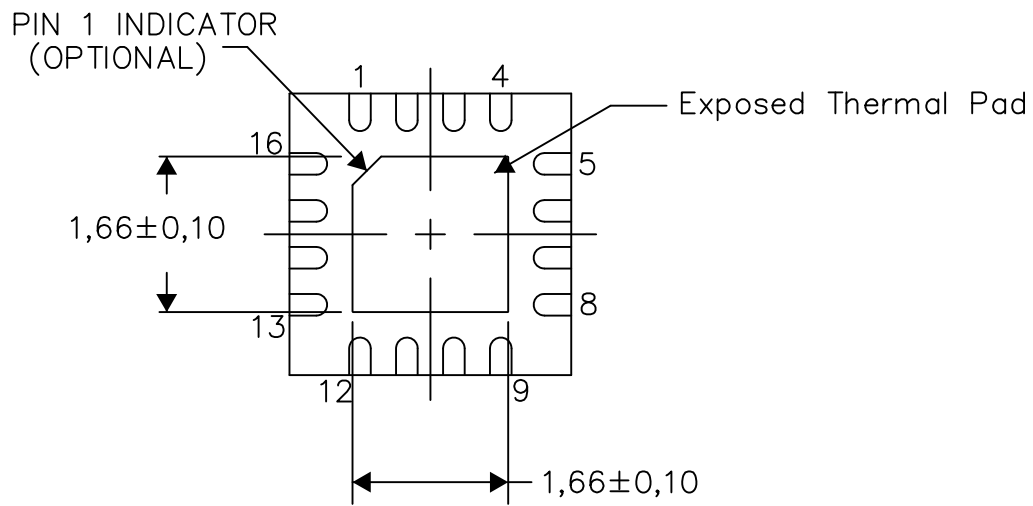

Bottom View

Exposed Thermal Pad Dimensions

4206446-8/U 08/15

NOTE: A. All linear dimensions are in millimeters

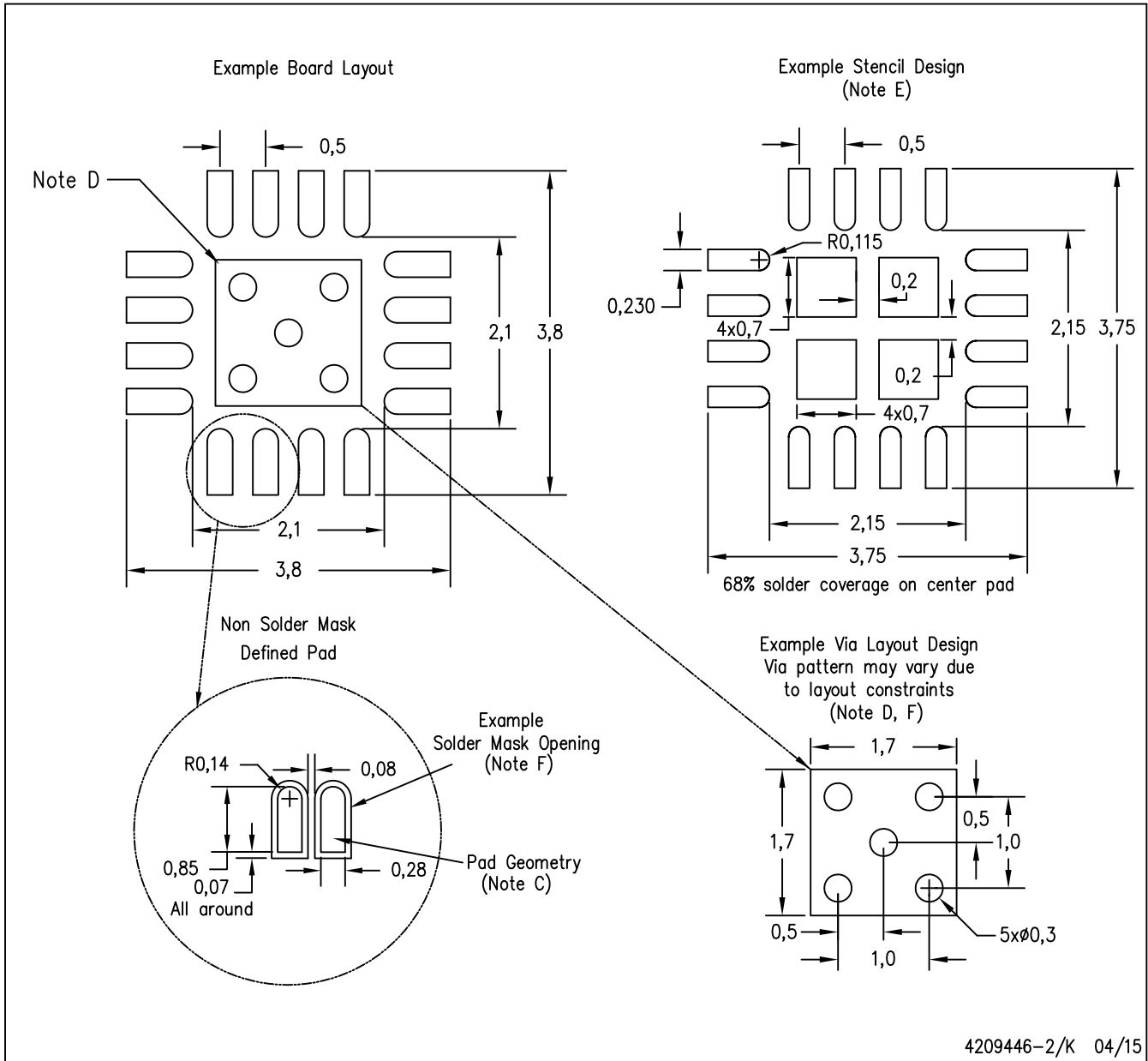

- NOTES:
- A. All linear dimensions are in millimeters.
  - B. This drawing is subject to change without notice.
  - C. Publication IPC-7351 is recommended for alternate designs.
  - D. This package is designed to be soldered to a thermal pad on the board. Refer to Application Note, Quad Flat-Pack Packages, Texas Instruments Literature No. SLUA271, and also the Product Data Sheets for specific thermal information, via requirements, and recommended board layout. These documents are available at [www.ti.com](http://www.ti.com) <<http://www.ti.com>>.
  - E. Laser cutting apertures with trapezoidal walls and also rounding corners will offer better paste release. Customers should contact their board assembly site for stencil design recommendations. Refer to IPC 7525 for stencil design considerations.
  - F. Customers should contact their board fabrication site for minimum solder mask web tolerances between signal pads.

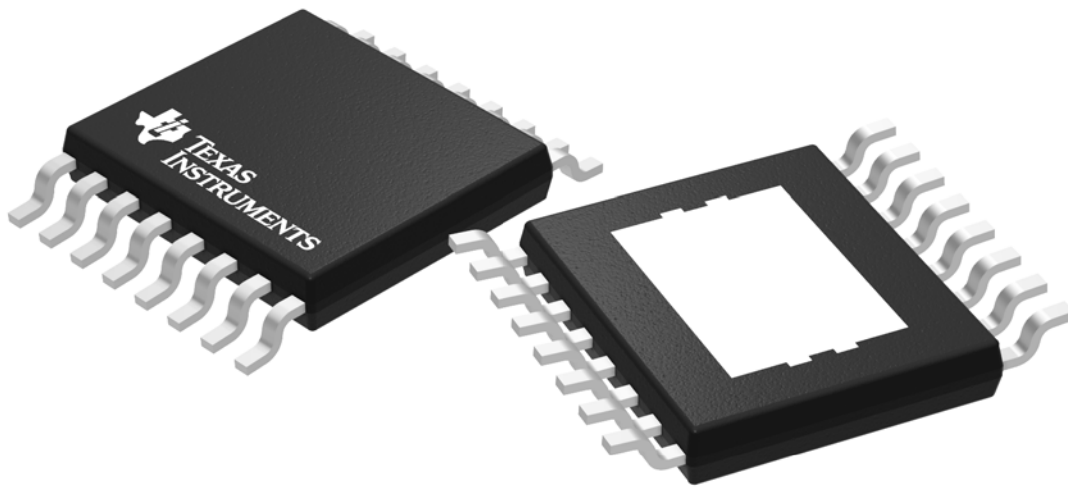

Images above are just a representation of the package family, actual package may vary.  
Refer to the product data sheet for package details.

# PWP0016C

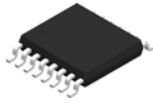

# PACKAGE OUTLINE

## PowerPAD™ TSSOP - 1.2 mm max height

SMALL OUTLINE PACKAGE

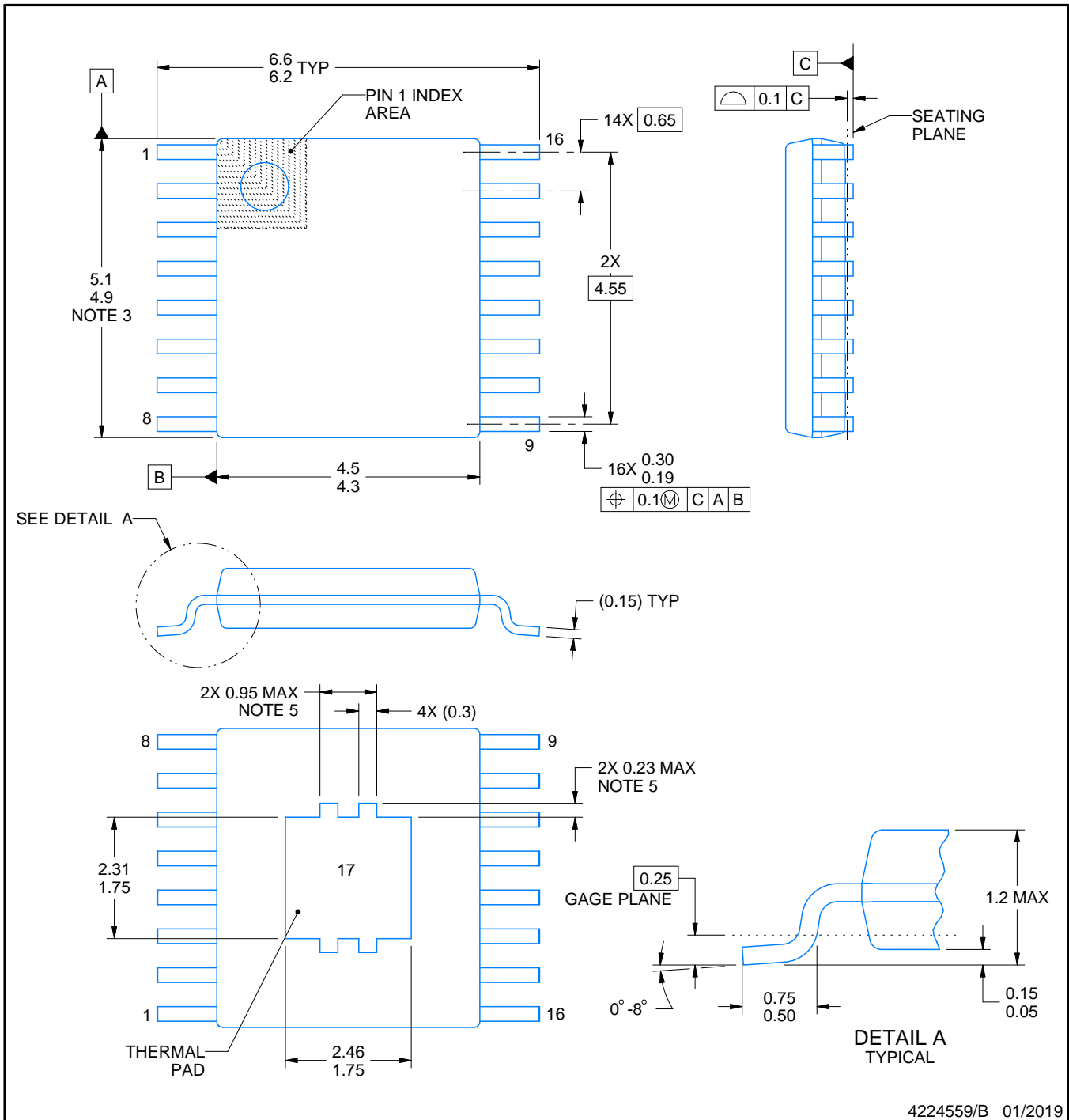

4224559/B 01/2019

**NOTES:**

PowerPAD is a trademark of Texas Instruments.

1. All linear dimensions are in millimeters. Any dimensions in parenthesis are for reference only. Dimensioning and tolerancing per ASME Y14.5M.
2. This drawing is subject to change without notice.
3. This dimension does not include mold flash, protrusions, or gate burrs. Mold flash, protrusions, or gate burrs shall not exceed 0.15 mm per side.
4. Reference JEDEC registration MO-153.
5. Features may differ or may not be present.



# EXAMPLE STENCIL DESIGN

PWP0016C

PowerPAD™ TSSOP - 1.2 mm max height

SMALL OUTLINE PACKAGE

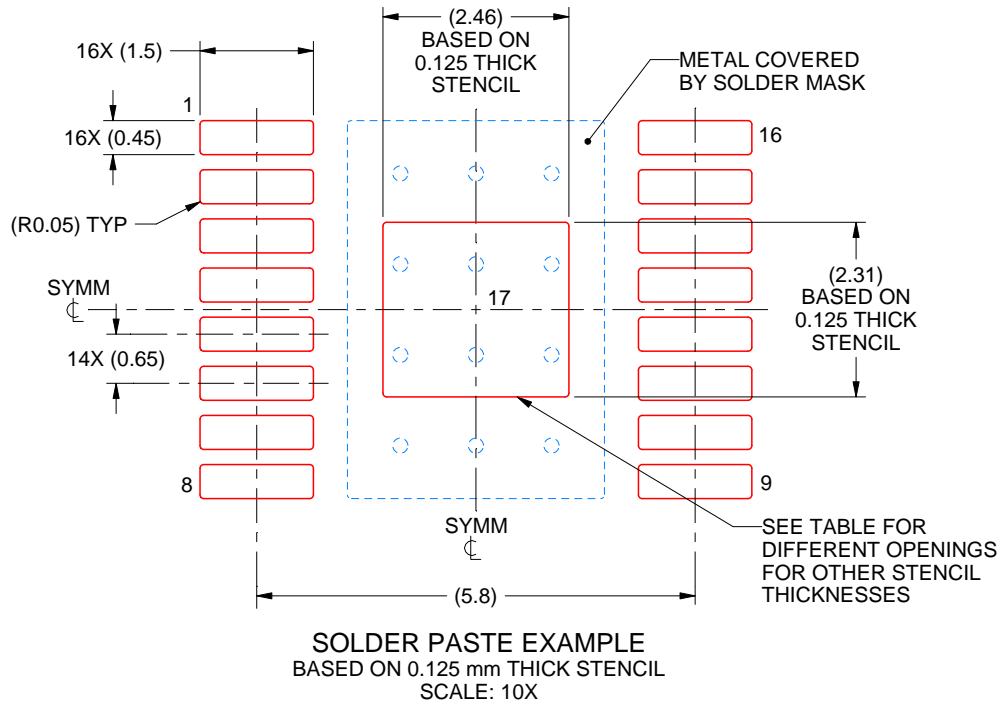

STENCIL THICKNESS	SOLDER STENCIL OPENING
0.1	2.75 X 2.58
0.125	2.46 X 2.31 (SHOWN)
0.15	2.25 X 2.11
0.175	2.08 X 1.95

4224559/B 01/2019

NOTES: (continued)

11. Laser cutting apertures with trapezoidal walls and rounded corners may offer better paste release. IPC-7525 may have alternate design recommendations.
12. Board assembly site may have different recommendations for stencil design.

## IMPORTANT NOTICE AND DISCLAIMER

TI PROVIDES TECHNICAL AND RELIABILITY DATA (INCLUDING DATA SHEETS), DESIGN RESOURCES (INCLUDING REFERENCE DESIGNS), APPLICATION OR OTHER DESIGN ADVICE, WEB TOOLS, SAFETY INFORMATION, AND OTHER RESOURCES "AS IS" AND WITH ALL FAULTS, AND DISCLAIMS ALL WARRANTIES, EXPRESS AND IMPLIED, INCLUDING WITHOUT LIMITATION ANY IMPLIED WARRANTIES OF MERCHANTABILITY, FITNESS FOR A PARTICULAR PURPOSE OR NON-INFRINGEMENT OF THIRD PARTY INTELLECTUAL PROPERTY RIGHTS.

These resources are intended for skilled developers designing with TI products. You are solely responsible for (1) selecting the appropriate TI products for your application, (2) designing, validating and testing your application, and (3) ensuring your application meets applicable standards, and any other safety, security, regulatory or other requirements.

These resources are subject to change without notice. TI grants you permission to use these resources only for development of an application that uses the TI products described in the resource. Other reproduction and display of these resources is prohibited. No license is granted to any other TI intellectual property right or to any third party intellectual property right. TI disclaims responsibility for, and you will fully indemnify TI and its representatives against, any claims, damages, costs, losses, and liabilities arising out of your use of these resources.

TI's products are provided subject to [TI's Terms of Sale](#) or other applicable terms available either on [ti.com](http://ti.com) or provided in conjunction with such TI products. TI's provision of these resources does not expand or otherwise alter TI's applicable warranties or warranty disclaimers for TI products.

TI objects to and rejects any additional or different terms you may have proposed.

Mailing Address: Texas Instruments, Post Office Box 655303, Dallas, Texas 75265  
Copyright © 2021, Texas Instruments Incorporated