

High Voltage Power Operational Amplifiers



FEATURES

- High Voltage— 900V ($\pm 450V$)
- Low Quiescent Current — 1.6mA
- Output Current — 100mA
- Programmable Current Limit

APPLICATIONS

- High Voltage Instrumentation
- Programmable Power Supplies Up To $\pm 430V$
- Mass Spectrometers
- Semiconductor Measurement Equipment



DESCRIPTION

The PA95 is a high voltage, MOSFET operational amplifier designed as a low cost solution for driving continuous output currents up to 100mA and pulse currents up to 200mA into capacitive loads. The safe operating area (SOA) has no second breakdown limitations and can be observed for all load types by choosing an appropriate current limiting resistor. The MOSFET output stage is biased AB for linear operation. External compensation provides flexibility in choosing bandwidth and slew rate for the application. Apex Microtechnology's Power SIP uses minimum board space allowing for high density circuit boards. The Power SIP is electrically isolated. Isolating thermal washers (TW13) are recommended to prevent arcing from pins to heatsink.

Figure 1: Equivalent Schematic

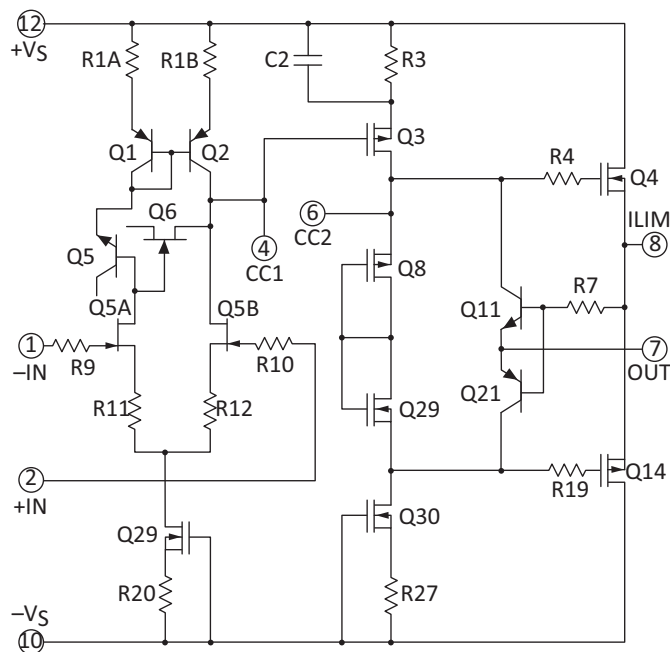

TYPICAL CONNECTION

Figure 2: Typical Connection

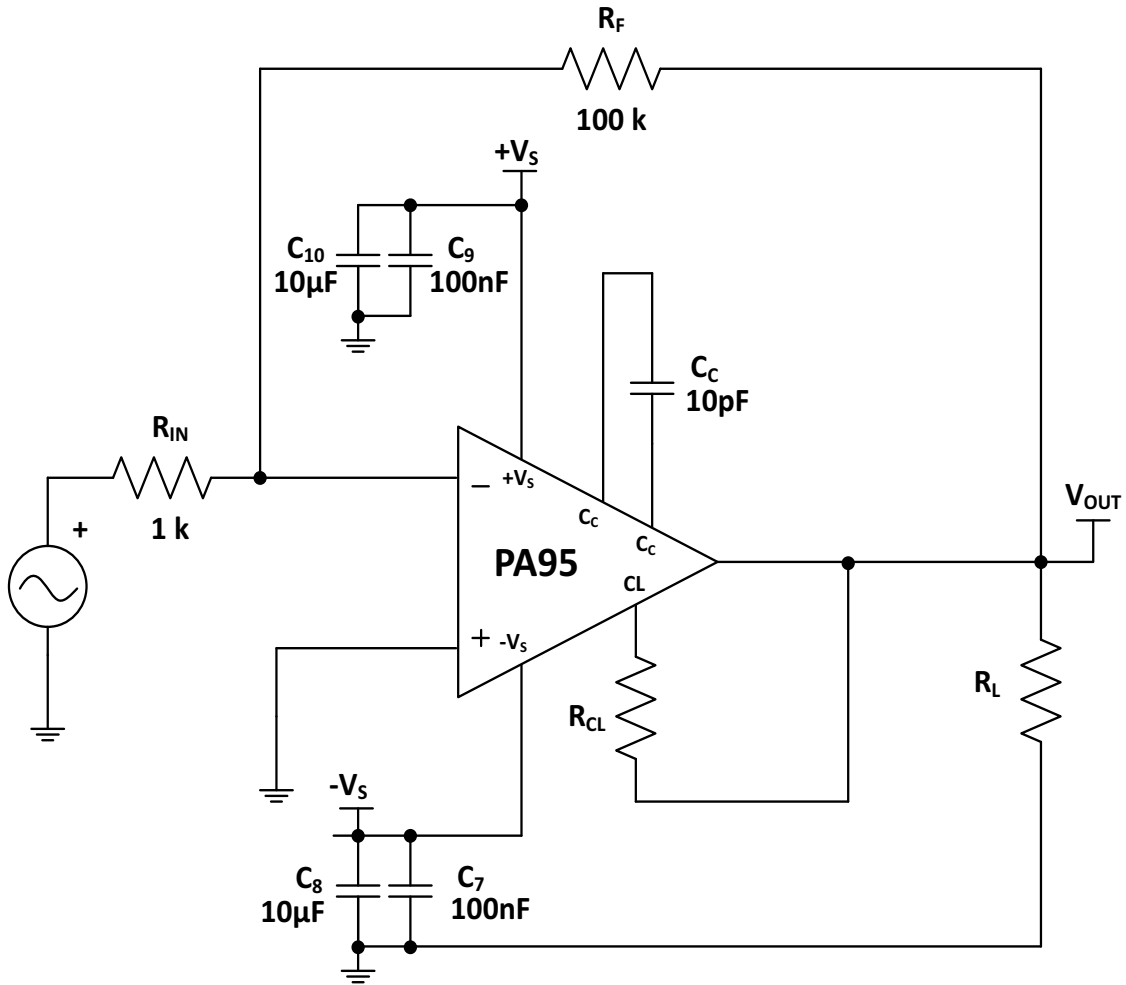

PINOUT AND DESCRIPTION TABLE

Figure 3: External Connections

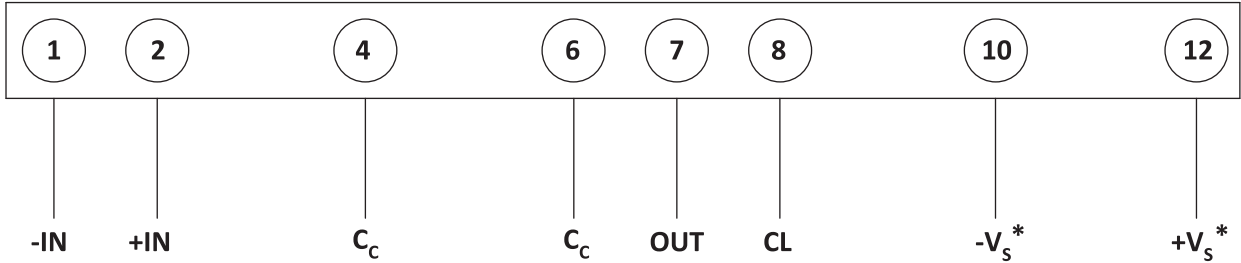

*0.01 μ F or greater ceramic power supply bypassing required.

Pin Number	Name	Description
1	-IN	The inverting input.
2	+IN	The non-inverting input.
4, 6	CC	Compensation capacitor connection. Select value based on Phase Compensation. See applicable section.
7	OUT	The output. Connect this pin to load and to the feedback resistors.
8	CL	Connect to the current limit resistor. Output current flows into/out of this pin through R_{CL} . The output pin and the load are connected to the other side of R_{CL} .
10	-Vs	The negative supply rail.
12	+Vs	The positive supply rail.

SPECIFICATIONS

Unless otherwise noted: $T_C = 25^\circ\text{C}$, DC input specifications are \pm value given. Power supply voltage is typical rating. $C_c = 4.7\text{pF}$.

ABSOLUTE MAXIMUM RATINGS

Parameter	Symbol	Min	Max	Units
Supply Voltage, $+V_S$ to $-V_S$	$+V_S$ to $-V_S$		900	V
Output Current, source, sink, within SOA	I_O		200	mA
Power Dissipation, continuous @ $T_C = 25^\circ\text{C}$	P_D		30	W
Input Voltage, differential	$V_{IN(Diff)}$	-20	20	V
Input Voltage, common mode ¹	V_{cm}	$-V_S$	$+V_S$	V
Temperature, pin solder, 10s max.			260	$^\circ\text{C}$
Temperature, junction ²	T_J		150	$^\circ\text{C}$
Temperature Range, storage		-55	125	$^\circ\text{C}$
Operating Temperature Range, case	T_C	-40	85	$^\circ\text{C}$

1. Although supply voltages can range up to $\pm 450\text{V}$ the input pins cannot swing over this range. The input pins must be at least 30V from either supply rail but not more than 500V from either supply rail. See text for a more complete description of the common mode voltage range.
2. Long term operation at the maximum junction temperature will result in reduced product life. Derate internal power dissipation to achieve high MTTF.

CAUTION

The PA95 is constructed from MOSFET transistors. ESD handling procedures must be observed. The substrate contains beryllia (BeO). Do not crush, machine or subject to temperatures in excess of 850°C to avoid generating toxic fumes.

INPUT

Parameter	Test Conditions	Min	Typ	Max	Units
Offset Voltage, initial			0.5	5	mV
Offset Voltage vs. temperature	Full temp range		15	50	$\mu\text{V}/^\circ\text{C}$
Offset Voltage vs. supply			10	25	$\mu\text{V}/\text{V}$
Offset Voltage vs. time			75		$\mu\text{V}/\text{hr}$
Bias Current, initial			200	2000	pA
Bias Current vs. supply			4		pA/V
Offset Current, initial			50	500	pA
Input Resistance, DC			10^{11}		Ω
Input Capacitance			4		pF
Common Mode Voltage Range ¹	$V_S = \pm 250\text{V}$	$\pm V_S \mp 30$			V
Common Mode Rejection, DC	$V_{CM} = \pm 90\text{V}$	80	98		dB
Noise	10 kHz bandwidth, $R_S = 1\text{ k}\Omega$		2		$\mu\text{V RMS}$

1. Although supply voltages can range up to $\pm 450\text{V}$ the input pins cannot swing over this range. The input pins must be at least 30V from either supply rail but not more than 500V from either supply rail. See text for a more complete description of the common mode voltage range.

GAIN

Parameter	Test Conditions	Min	Typ	Max	Units
Open Loop @ 15 Hz	$R_L = 5\text{ k}\Omega$	94	118		dB
Gain Bandwidth Product @ 1 MHz	$R_L = 5\text{ k}\Omega$		10		MHz
Power Bandwidth	$R_L = 5\text{ k}\Omega$		20		kHz
Phase Margin, $A_V = 10$	Full temp range		60		$^\circ$

OUTPUT

Parameter	Test Conditions	Min	Typ	Max	Units
Voltage Swing	$I_O = 70\text{mA}$	$\pm V_S \mp 24$	$\pm V_S \mp 20$		V
Current, Continuous		100			mA
Slew Rate, $A_V = 100$	$C_C = 4.7\text{pF}$		30		$\text{V}/\mu\text{s}$
Settling Time, to 0.1%	2V Step		1		μs
Resistance	no load		100		Ω

POWER SUPPLY

Parameter	Test Conditions	Min	Typ	Max	Units
Voltage ¹		±50	±300	±450	V
Current, quiescent			1.6	2.2	mA

1. Derate max supply rating 0.625 V/°C below 25°C case. No derating needed above 25°C case.

THERMAL

Parameter	Test Conditions	Min	Typ	Max	Units
Resistance, AC, junction to case ¹	Full temp range, F > 60 Hz			2.5	°C/W
Resistance, DC, junction to case	Full temp range, F < 60 Hz			4.2	°C/W
Resistance, junction to air	Full temp range		30		°C/W
Temperature Range, case		-25		+85	°C

1. Rating applies if the output current alternates between both output transistors at a rate faster than 60 Hz.

TYPICAL PERFORMANCE GRAPHS

Figure 4: Power Derating

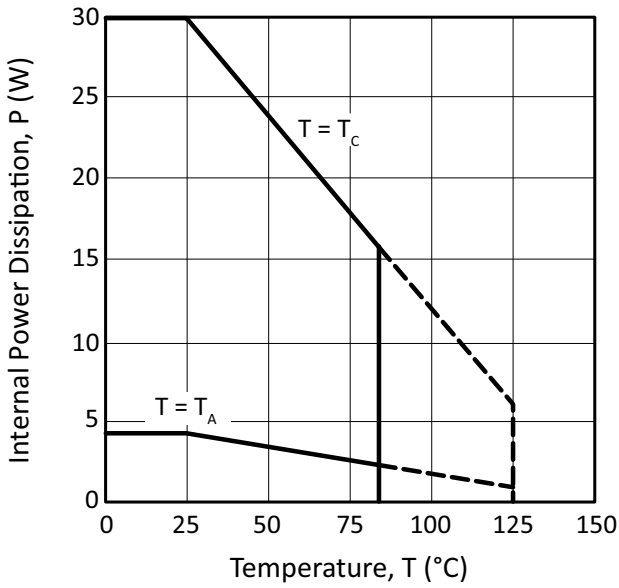

Figure 5: Quiescent Current

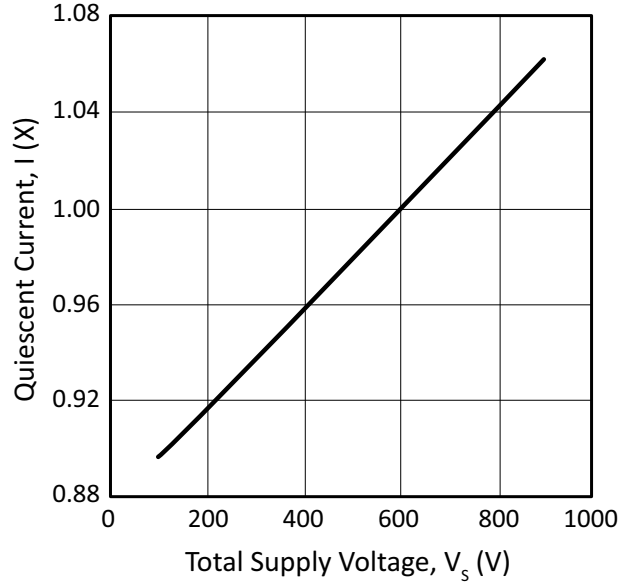

Figure 6: Small Signal Response

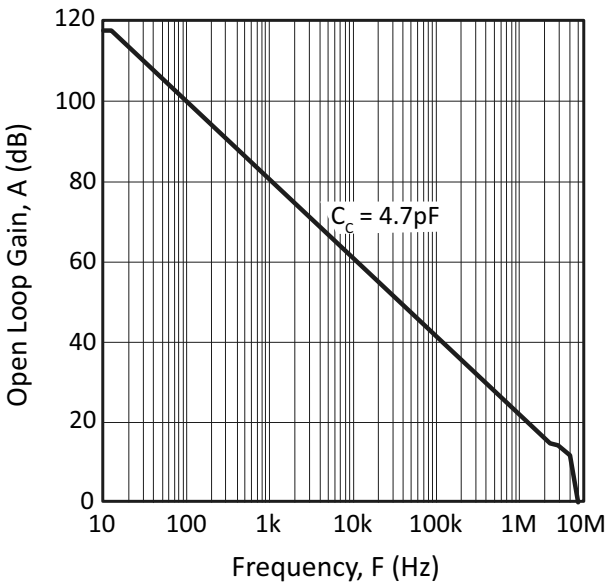

Figure 7: Phase Response

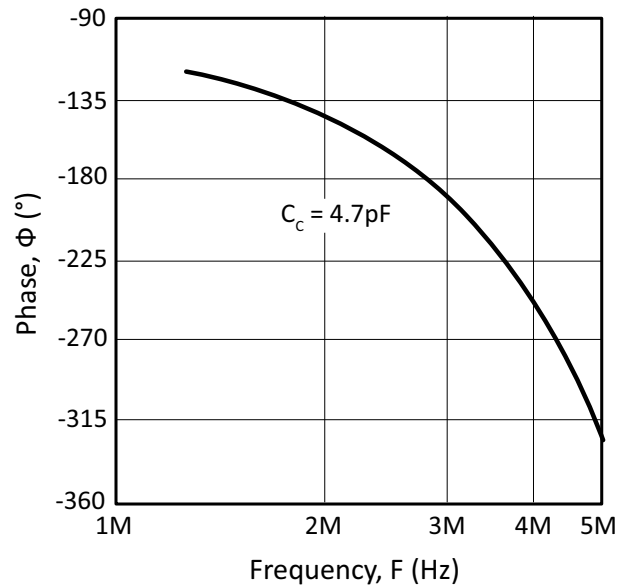

Figure 8: Output Voltage Swing

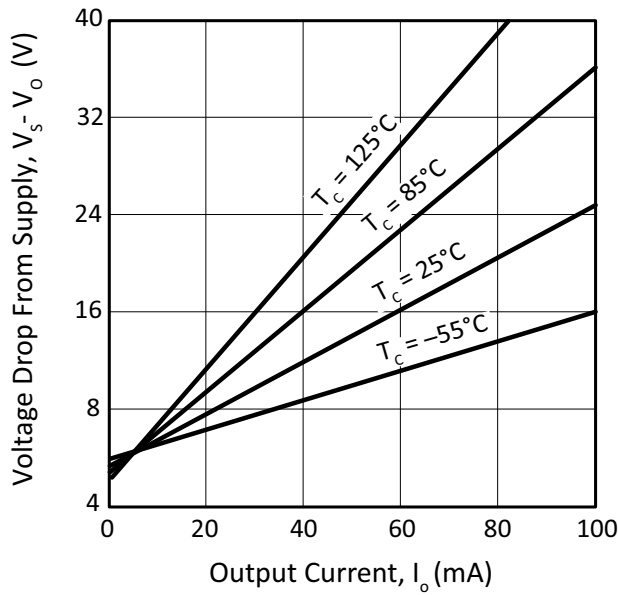

Figure 9: Power Response

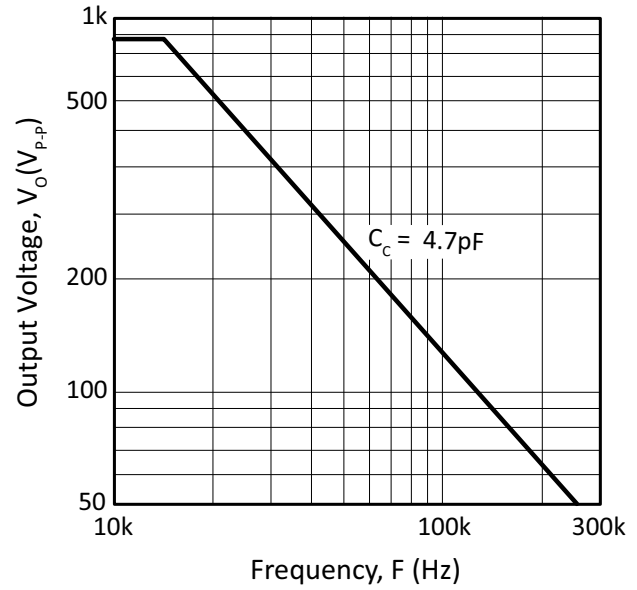

Figure 10: Current Limit

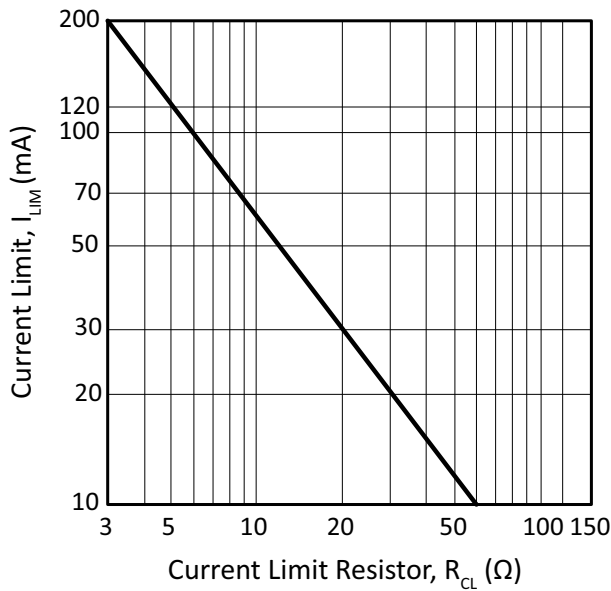
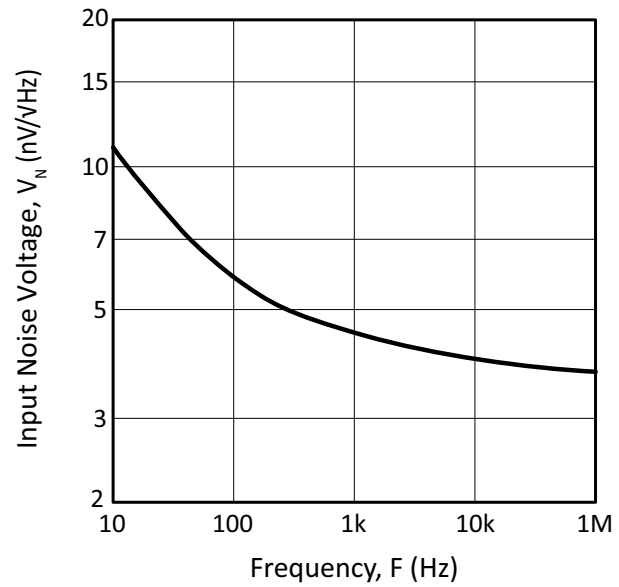
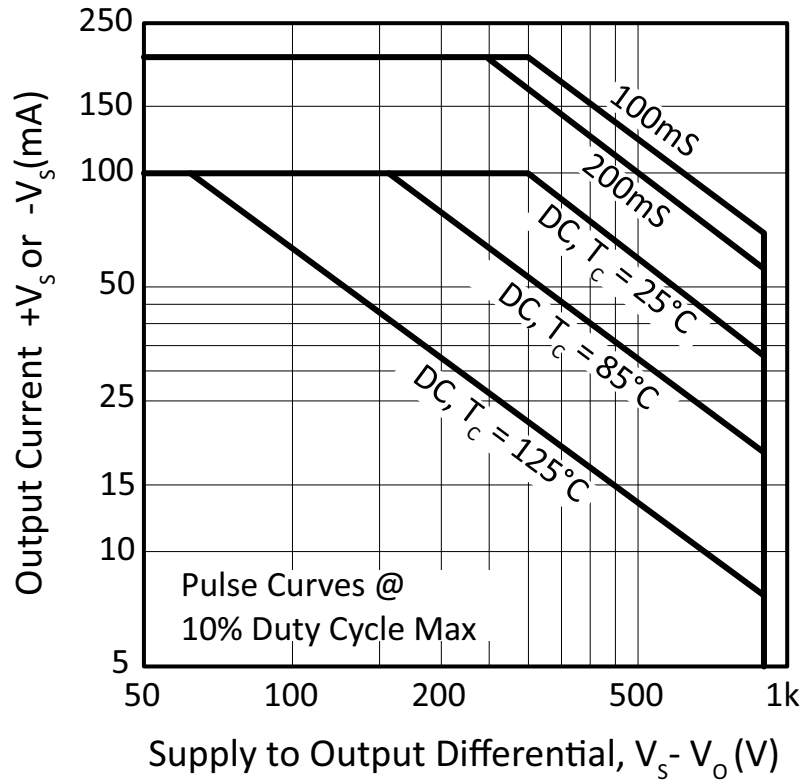

Figure 11: Input Noise



SAFE OPERATING AREA (SOA)

Figure 12: Safe Operating Area



GENERAL

Please read Application Note 1 “General Operating Considerations” which covers stability, supplies, heat sinking, mounting, current limit, SOA interpretation, and specification interpretation. Visit www.apexanalog.com for Apex Microtechnology’s complete Application Notes library, Technical Seminar Workbook, and Evaluation Kits.

TYPICAL APPLICATION

Piezo positioning may be applied to the focusing of segmented mirror systems. The composite mirror may be composed of hundreds of elements, each requiring focusing under computer control. In such complex systems the PA95 reduces the costs of power supplies and cooling with its advantages of low cost and low quiescent power consumption while increasing circuit density with the SIP.

Figure 13: Typical Application

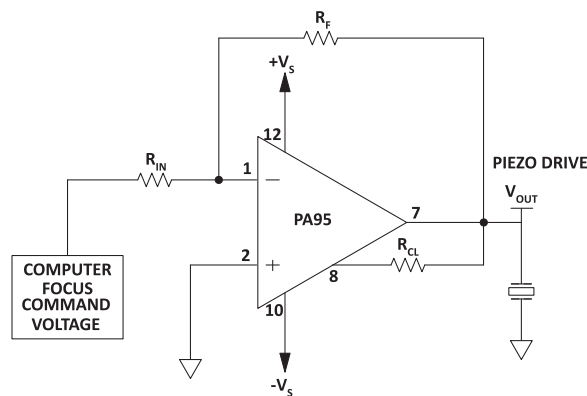

PHASE COMPENSATION

Gain	C _C
≥100	4.7pF

Note: C_C rated for full supply voltage

CURRENT LIMIT

For proper operation, the current limit resistor (R_{CL}) must be connected as shown in the external connection diagram. The minimum value is 3.5 ohm, however for optimum reliability the resistor value should be set as high as possible. The value is calculated as follows; with the maximum practical value of 150 ohms.

$$R_{CL}(\Omega) = \frac{0.7V}{I_{LIM}(A)}$$

COMMON MODE INPUT RANGE

Operational amplifiers are usually designed to have a common mode input voltage range that approximates the power supply voltage range. However, to keep the cost as low as possible and still meet the requirements of most applications the common mode input voltage range of the PA95 is restricted. The input

pins must always be a least 30V from either supply voltage but never more than 500V. This means that the PA95 cannot be used in applications where the supply voltages are extremely unbalanced. For example, supply voltages of +800V and -100V would not be allowed in an application where the non-inverting pin is grounded because in normal operation both input pins would be at 0V and the difference voltage between the positive supply and the input pins would be 800V. In this kind of application, however, supply voltages +500V and -100V does meet the input common mode voltage range requirements since the maximum difference voltage between the inputs pins and the supply voltage is 500V (the maximum allowed). The output has no such restrictions on its voltage swing. The output can swing within 24V of either supply voltage regardless of value so long as the total supply voltage does not exceed 900V.

INPUT PROTECTION

Although the PA95 can withstand differential input voltages up to $\pm 20V$, additional external protection is recommended. In most applications 1N4148 or 1N914 signal diodes are sufficient (D1, D2 in Figure 14A). In more demanding applications where low leakage or low capacitance are of concern 2N4416 or 2N5457-2N5459 JFETs connected as diodes will be required (Q1, Q2 in Figure 14B). In either case the input differential voltage will be clamped to $\pm 0.7V$. This is sufficient overdrive to produce maximum power bandwidth. Note that this protection does not automatically protect the amplifier from excessive common mode input voltages.

Figure 14: Overvoltage Protection

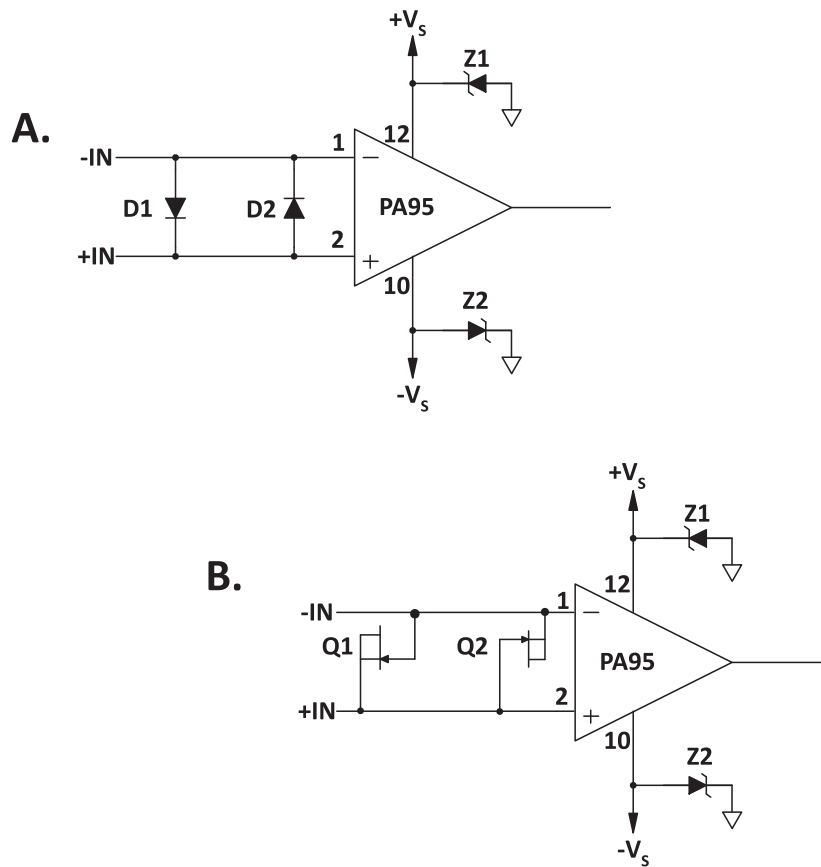

POWER SUPPLY PROTECTION

Unidirectional zener diode transient suppressors are recommended as protection on the supply pins. The zeners clamp transients to voltages within the power supply rating and also clamp power supply reversals to ground. Whether the zeners are used or not, the system power supply should be evaluated for transient performance including power-on overshoot and power-off polarity reversal as well as line regulation. Conditions which can cause open circuits or polarity reversals on either power supply rail should be avoided or protected against. Reversals or opens on the negative supply rail is known to induce input stage failure. Unidirectional transzors prevent this, and it is desirable that they be both electrically and physically as close to the amplifier as possible.

STABILITY

The PA95 is stable at gains of 10 or more with a NPO (COG) compensation capacitor of 4.7pF. The compensation capacitor, C_c , in the external connections diagram must be rated at 1000V working voltage and mounted closely to pins 4 and 6 to prevent spurious oscillation. A compensation capacitor less than 4.7pF is not recommended.

EXTERNAL COMPONENTS

Of great importance are the voltage rating and voltage coefficient of the gain setting feedback resistor. Typical voltage ratings of low wattage resistors are 150 to 250V. Up to 500 V can appear across the feedback resistor. High voltage rated resistors can be obtained. However a 1 M Ω feedback resistor composed of five 200k resistors in series will produce the proper voltage rating.

CAUTIONS

The operating voltages of the PA95 are potentially lethal. During circuit design develop a functioning circuit at the lowest possible voltages. Clip test leads should be used for “hands off” measurements while troubleshooting.

PA95

PACKAGE STYLE EC

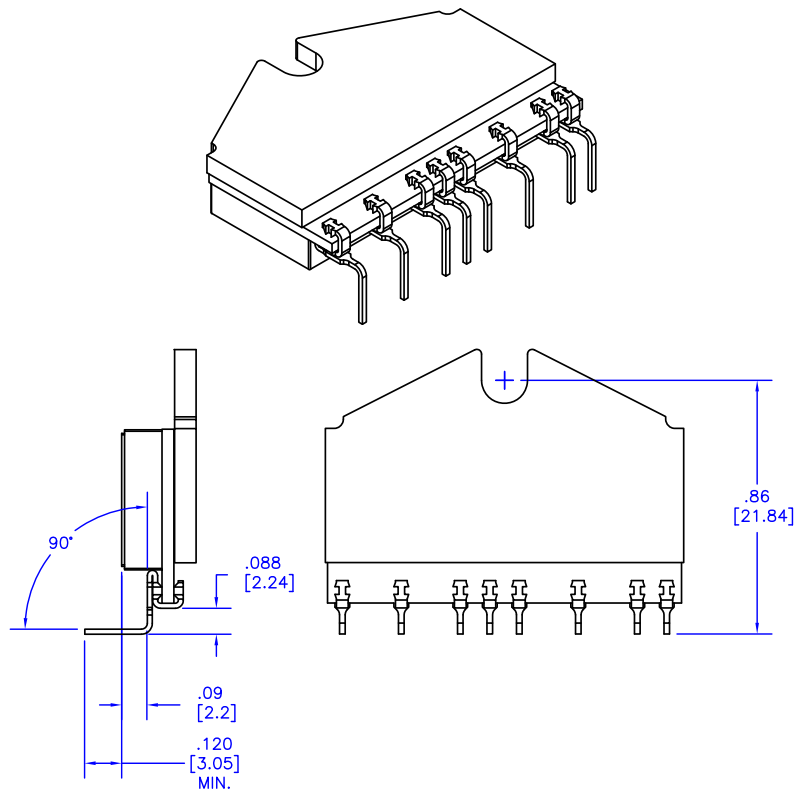

NOTES:

1. Dimensions are inches & [mm].
2. For other dimensions and information on this package with unformed leads, see package DQ.

PACKAGE STYLE RC

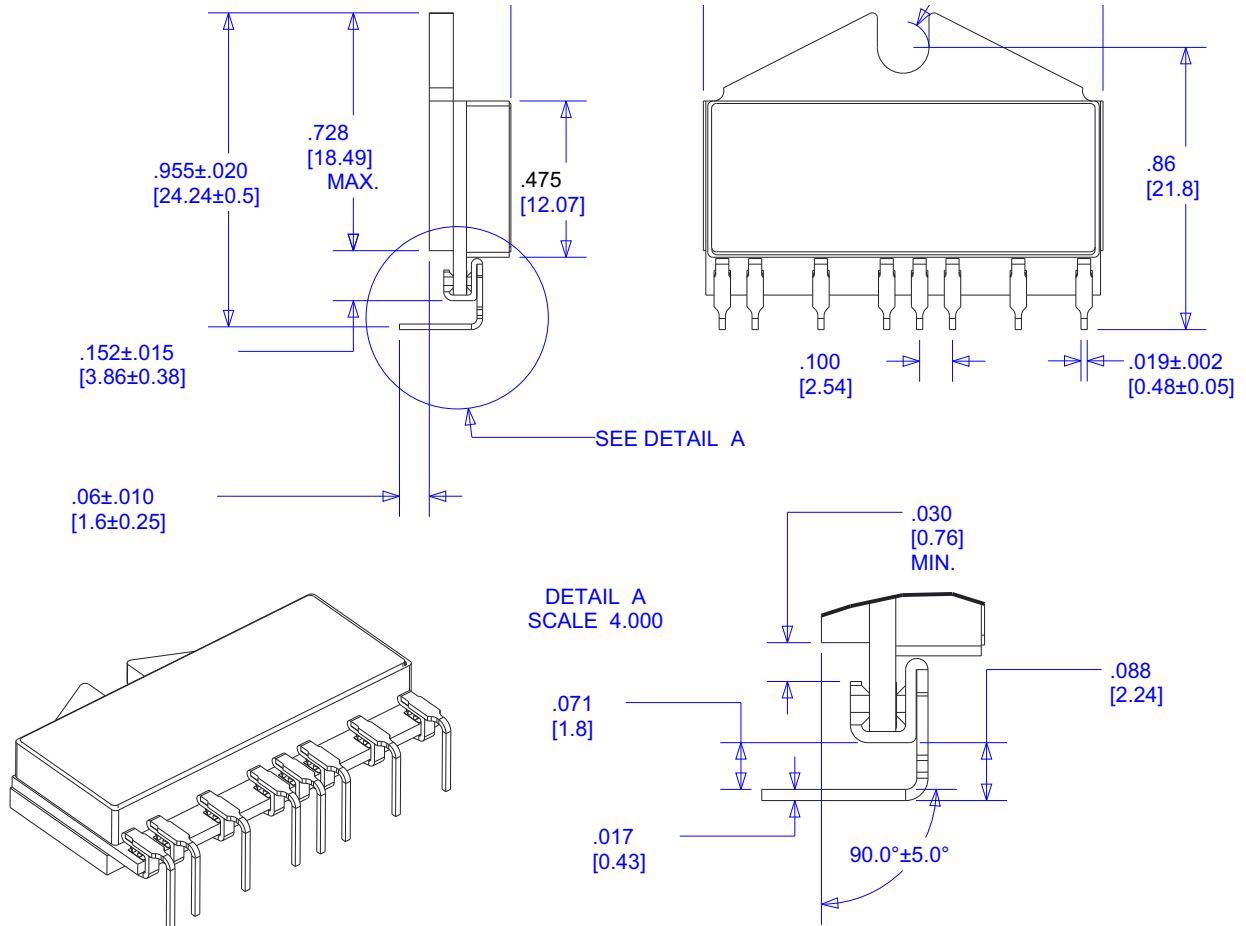

NOTES:

1. Dimensions are in inches & [mm].
2. Triangle on lid denotes Pin 1.
3. Pins: Alloy 510 phosphor bronze plated with matte tin (150-300 microinches) over nickel (50 microinches max.) underplate.
4. Package: Vectra liquid crystal polymer (black), beryllium oxide substrate, and nickel plated C.R.S header.
5. Epoxy-sealed and ultrasonically welded non-hermetic package.
6. Package weight: .37 oz [11.4 g]

NEED TECHNICAL HELP? CONTACT APEX SUPPORT!

For all Apex Microtechnology product questions and inquiries, call toll free 800-546-2739 in North America. For inquiries via email, please contact apex.support@apexanalog.com. International customers can also request support by contacting their local Apex Microtechnology Sales Representative. To find the one nearest to you, go to www.apexanalog.com

IMPORTANT NOTICE

Apex Microtechnology, Inc. has made every effort to insure the accuracy of the content contained in this document. However, the information is subject to change without notice and is provided "AS IS" without warranty of any kind (expressed or implied). Apex Microtechnology reserves the right to make changes without further notice to any specifications or products mentioned herein to improve reliability. This document is the property of Apex Microtechnology and by furnishing this information, Apex Microtechnology grants no license, expressed or implied under any patents, mask work rights, copyrights, trademarks, trade secrets or other intellectual property rights. Apex Microtechnology owns the copyrights associated with the information contained herein and gives consent for copies to be made of the information only for use within your organization with respect to Apex Microtechnology integrated circuits or other products of Apex Microtechnology. This consent does not extend to other copying such as copying for general distribution, advertising or promotional purposes, or for creating any work for resale.

APEX MICROTECHNOLOGY PRODUCTS ARE NOT DESIGNED, AUTHORIZED OR WARRANTED TO BE SUITABLE FOR USE IN PRODUCTS USED FOR LIFE SUPPORT, AUTOMOTIVE SAFETY, SECURITY DEVICES, OR OTHER CRITICAL APPLICATIONS. PRODUCTS IN SUCH APPLICATIONS ARE UNDERSTOOD TO BE FULLY AT THE CUSTOMER OR THE CUSTOMER'S RISK.

Apex Microtechnology, Apex and Apex Precision Power are trademarks of Apex Microtechnology, Inc. All other corporate names noted herein may be trademarks of their respective holders.