

Specifications:

规格:
 Voltage rating: 250V AC/DC
 额定电压: 250V AC/DC
 Current rating: 3A AC/DC
 额定电流: 3A AC/DC
 Withstanding voltage: 1000V AC/minute
 耐受电压: 1000V AC/分钟
 Temperature range: -25°C~+85°C
 温度范围: -25°C~+85°C
 Insulation resistance: ≥1000MΩ
 绝缘电阻: ≥1000MΩ
 Contact resistance: ≤30mΩ
 接触电阻: ≤30mΩ
 After environmental testing: ≤40mΩ
 环境测试后: ≤40兆欧

X2011 W V S-XX A-9T SN XX

① ② ③ ④ ⑤ ⑥ ⑦ ⑧ ⑨

1. Series No
2. Category: W-WAFER
3. Welding Board Angle: V-Straight 180°
4. Welding Way: S-SMT
5. Row No-Pin No: XX-02P~16P
6. Plug the Pin&Special No: A-With Located Block
7. Material: 9T: PA9T UL 94V-0
8. Plating Category: SN-Bright Tin Plating
9. Color: Blank-Natural Color

poles	Dimensions(mm)		poles	Dimensions(mm)	
	A	B		A	B
2	2.00	8.00	10	18.00	24.00
3	4.00	10.00	11	20.00	26.00
4	6.00	12.00	12	22.00	28.00
5	8.00	14.00	13	24.00	30.00
6	10.00	16.00	14	26.00	32.00
7	12.00	18.00	15	28.00	34.00
8	14.00	20.00	16	30.00	36.00
9	16.00	22.00			

X2011WVS-XXA-9TSN	PA9T UL 94V-0	Brass	Phosphor Bronze	Tin-Plated	X2011H-A
PART NO	Material	Material(pin)	Material(Solder Tab)	Finish(Pin and Solder tab)	Suitable XKB Terminal

广东星坤科技股份有限公司

生 日期
 ΔX 效
 ΔX 日期
 ΔX 文件工程章
 MARK

DESCRIPTION	DATE	REVISED	APPROVED	units: mm
				tolerance:
				X.X ±0.2mm
				X.XX ±0.1mm
				X.XXX ±0.05mm
UNSPECIFIED TOLERANCES				

DSND		DATE		SCALE: N/A	MODEL TYPE: Wire to board connector
DWN		DATE		VIEW:	PART NO.: 2.00mm Crimp Style Connectors
CHKD		DATE		UNIT: mm/in	DWG NO.: X2011WVS-XXA-9TSN
APPD		DATE		SIZE: A4	
XKB INDUSTRIAL PRECISION CO., LIMITED				WEIGHT	SHEET
				1.0g	1/1
				REVISION	A0

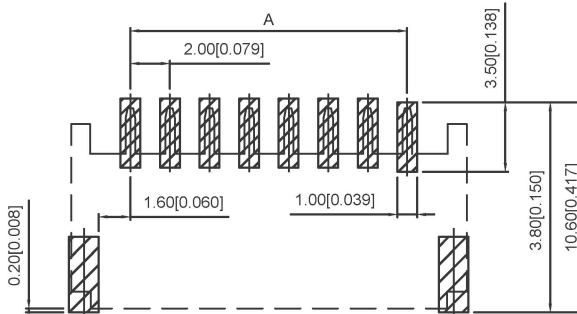
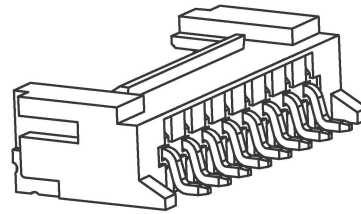
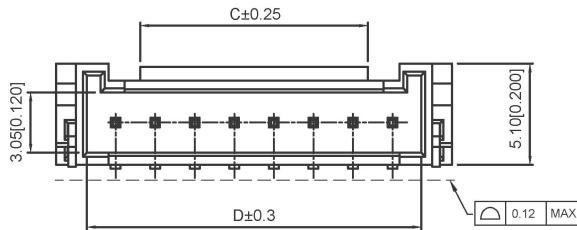
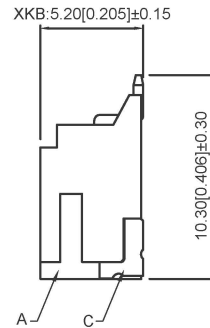
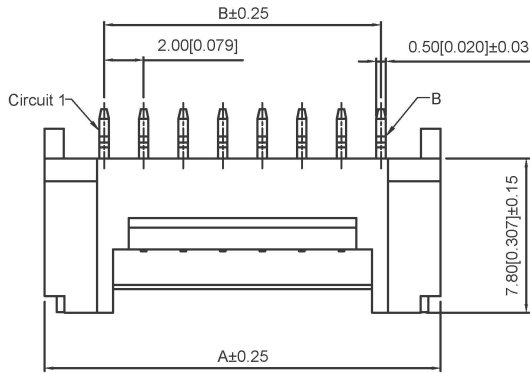

Assembly Layout

Specifications:

规格:
 Voltage rating: 250V AC/DC
 额定电压: 250V AC/DC
 Current rating: 3A AC/DC
 额定电流: 3A AC/DC
 Withstanding voltage: 1000V AC/minute
 耐受电压: 1000V AC/分钟
 Temperature range: -25°C~+85°C
 温度范围: -25°C~+85°C
 Insulation resistance: ≥1000MΩ
 绝缘电阻: ≥1000MΩ
 Contact resistance: ≤30mΩ
 接触电阻: ≤30mΩ
 After environmental testing: ≤40mΩ
 环境测试后: ≤40兆欧

X2011 W R S-XX A -9T SN XX

- ① ② ③ ④ ⑤ ⑥ ⑦ ⑧ ⑨

1. Series No
2. Category: W-WAFER
3. Welding Board Angle: R-Right Angle 90°
4. Welding Way: S-SMT
5. Row No-Pin No: XX-02P~16P
6. Plug the Pin&Special NO:
A-With Located Block
7. Material: 9T: PA9T UL 94V-0
8. Plating Category: SN-Bright Tin Plating
9. Color: Blank-Natural Color

poles	Dimensions(mm)				poles	Dimensions(mm)			
	A	B	C	D		A	B	C	D
2	8.00	2.00	2.70	4.75	10	24.00	18.00	15.50	20.90
3	10.00	4.00	3.20	6.75	11	26.00	20.00	15.50	22.90
4	12.00	6.00	3.50	8.90	12	28.00	22.00	15.50	24.90
5	14.00	8.00	5.50	10.90	13	30.00	24.00	15.50	26.90
6	16.00	10.00	7.50	12.90	14	32.00	26.00	15.50	28.90
7	18.00	12.00	9.50	14.90	15	34.00	28.00	15.50	30.90
8	20.00	14.00	11.50	16.90	16	36.00	30.00	15.50	32.90
9	22.00	16.00	13.50	18.90					

X2011WRS-XXA-9TSN	PA9T UL 94V-0	Brass	Phosphor Bronze	Tin-Plated	X2011H-A
PART NO	Material	Material(pin)	Material(Solder Tab)	Finish(Pin and Solder tab)	Suitable XKB Terminal

广东星坤科技股份有限公司
 Board layout
 General Tolerance: ±0.05

生	日期
ΔX	ΔX
ΔX	ΔX
MARK	文件工程章
DESCRIPTION	REVISIONS
DATE	REVISED
APPROVED	UNSPECIFIED TOLERANCES
www.xk-dg.cn	www.helloxkb.com
www.helloxkb.cn	

DSND	DATE	SCALE: N/A	MODEL TYPE: Wire to board connector
DWN	DATE	VIEW:	PART NO.: 2.00mm Crimp Style Connectors
CHKD	DATE	UNIT: mm/in	DWG NO.: X2011WRS-XXA-9TSN
APPD	DATE	SIZE: A4	WEIGHT 1.0g
XKB INDUSTRIAL PRECISION CO., LIMITED			SHEET 1/1
			REVISION A0

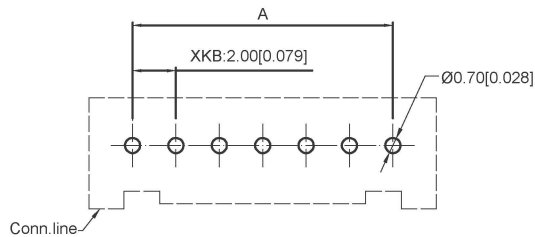
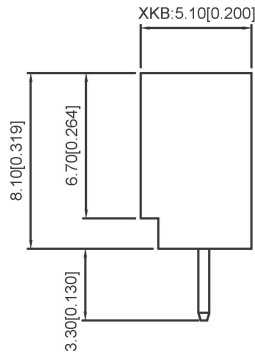
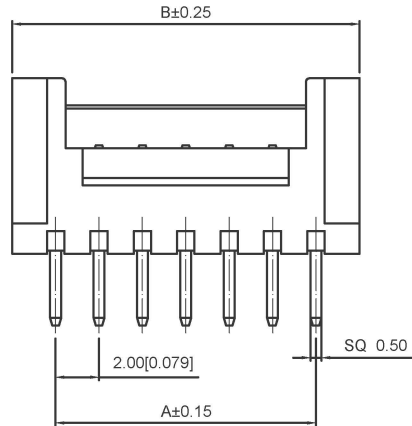
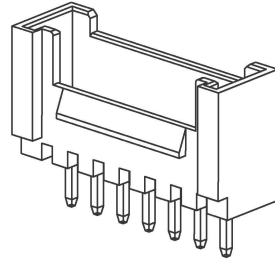
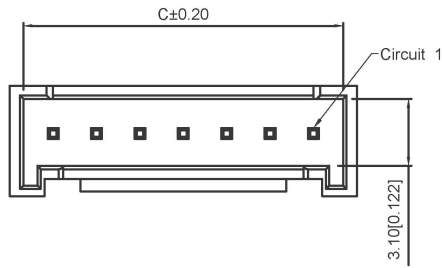

Specifications:

规格:
 Voltage rating:250V AC/DC
 额定电压: 250V AC/DC
 Current rating:3A AC/DC
 额定电流: 3A AC/DC
 Withstanding voltage:1000V AC/minute
 耐受电压: 1000V AC/分钟
 Temperature range:-25℃~+85℃
 温度范围: -25℃~+85℃
 Insulation resistance:≥1000MΩ
 绝缘电阻: ≥1000MΩ
 Contact resistance:≤30mΩ
 接触电阻: ≤30mΩ
 After environmental testing:≤40mΩ
 环境测试后: ≤40兆欧

X2011 W V X-XX A HF-XX XX XX

① ② ③ ④ ⑤ ⑥ ⑦ ⑧ ⑨ ⑩

- 1.Series No
- 2.Category:W-WAFER
- 3.Welding Board Angle:V-Straight 180°
- 4.Welding Way:Blank-DIP
- 5.Row No-Pin No:XX-02P~16P
- 6.Plug the Pin&Special No:A-Without Baffle
- 7.HF-Halogen Free
- 8.Material:NO-PA66 UL 94V-0;LCP 94V-0
- 9.Plating Category:SN-Bright Tin Plating
SW-Matte Tin Plating
- 10.Color:Blank-Natural Color

poles	Dimensions(mm)			poles	Dimensions(mm)		
	A	B	C		A	B	C
2	2.00	6.00	4.75	10	18.00	22.00	20.75
3	4.00	8.00	6.75	11	20.00	24.00	22.75
4	6.00	10.00	8.75	12	22.00	26.00	24.75
5	8.00	12.00	10.75	13	24.00	28.00	26.75
6	10.00	14.00	12.75	14	26.00	30.00	28.75
7	12.00	16.00	14.75	15	28.00	32.00	30.75
8	14.00	18.00	16.75	16	30.00	34.00	32.75
9	16.00	20.00	18.75				

X2011WV-XXA-LPSW	LCP 94V-0	Brass	Matte Tin-Plated	X2011h
X2011WV-XXAHF-N0SN	PA66 UL 94V-0 Halogen Free		Tin-Plated	
X2011WV-XXA-N0SN	PA66 UL 94V-0			
PART NO	Material	Material(pin)	Finish(pin)	Suitable XKB Terminal

广东星坤科技股份有限公司
 Recommended PCB Layout
 General Tolerance:±0.05

生效日期	文件工程章	DESCRIPTION	DATE	REVISED	APPROVED	UNSPECIFIED TOLERANCES

units:	mm
tolerance:	
X.X	±0.2mm
X.XX	±0.1mm
X.XXX	±0.05mm

DSND	DATE	SCALE: N/A
DWN	DATE	VIEW:
CHKD	DATE	UNIT: mm/in
APPD	DATE	SIZE: A4

MODEL TYPE:	WEIGHT	SHEET	REVISION
Wire to board connector	1.0g	1/1	A0
PART NO.: 2.00mm Crimp Style Connectors			
DWG NO.: X2011WV-XXAXX-XXXX			

XKB INDUSTRIAL PRECISION CO., LIMITED

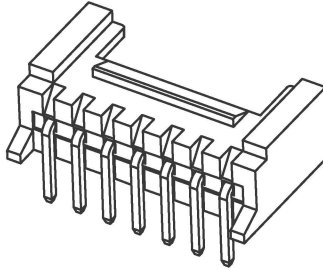
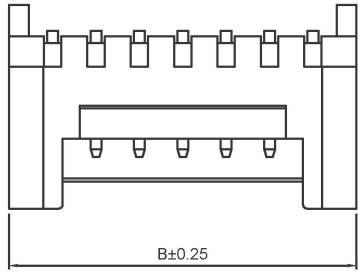

Specifications:

规格:
 Voltage rating:250V AC/DC
 额定电压: 250V AC/DC
 Current rating:3A AC/DC
 额定电流: 3A AC/DC
 Withstanding voltage:1000V AC/minute
 耐受电压: 1000V AC/分钟
 Temperature range:-25℃~+85℃
 温度范围: -25℃~+85℃
 Insulation resistance:≥1000MΩ
 绝缘电阻: ≥1000MΩ
 Contact resistance:≤30mΩ
 接触电阻: ≤30mΩ
 After environmental testing:≤40mΩ
 环境测试后: ≤40兆欧

X2011 W R X-XX A HF-N0 SN XX

① ② ③ ④ ⑤ ⑥ ⑦ ⑧ ⑨ ⑩

- 1.Series No
- 2.Category:W-WAFER
- 3.Welding Board Angle:R-Right Angle 90°
- 4.Welding Way:Blank-DIP
- 5.Row No-Pin No:XX-02P~16P
- 6.Plug the Pin&Special NO:
A-With Link Stopper DIP-3.2mm
- 7.HF-Halogen Free
- 8.Material:N0-PA66 UL 94V-0
- 9.Plating Category:SN-Bright Tin Plating
- 10.Color:Blank-Natural Color

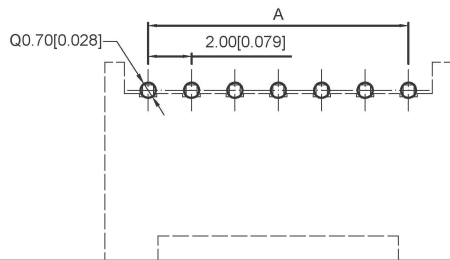
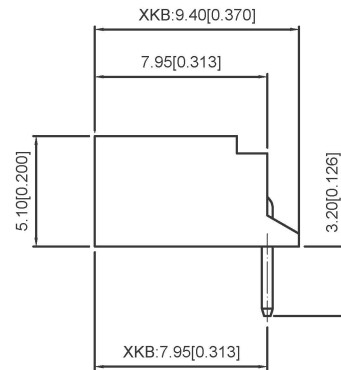
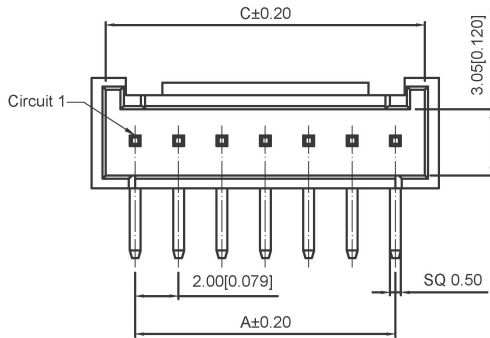

poles	Dimensions(mm)			poles	Dimensions(mm)		
	A	B	C		A	B	C
2	2.00	8.00	4.70	10	18.00	22.00	20.70
3	4.00	10.00	6.70	11	20.00	24.00	22.70
4	6.00	12.00	8.70	12	22.00	26.00	24.70
5	8.00	14.00	10.70	13	24.00	28.00	26.70
6	10.00	16.00	12.70	14	26.00	30.00	28.70
7	12.00	18.00	14.70	15	28.00	32.00	30.70
8	14.00	20.00	16.70	16	30.00	34.00	32.70
9	16.00	22.00	18.70				

X2011WR-XXAHF-N0 SN	PA66 UL 94V-0 Halogen Free	Brass	Tin-Plated	X2011H
X2011WR-XXA-N0SN	PA66 UL 94V-0			
PART NO	Material	Material(pin)	Finish(Pin)	Suitable XKB Terminal

广东星坤科技股份有限公司
 Recommended PCB Layout
 General Tolerance±0.05

生	日期	DESCRIPTION	DATE	REVISED	APPROVED	units:	mm
ΔX						tolerance:	
ΔX						X.X	±0.2mm
ΔX						X.XX	±0.1mm
MARK						X.XXX	±0.05mm
文件工程章						UNSPECIFIED TOLERANCES	
REVISIONS							
www.xk-dg.cn www.helloxkb.com www.helloxkb.cn							

DSND		DATE		SCALE: N/A	MODEL TYPE: Wire to board connector	
DWN		DATE		VIEW:	PART NO.:	
CHKD		DATE		UNIT: mm/in	2.00mm Crimp Style Connectors	
APPD		DATE		SIZE: A4	DWG NO.: X2011WR-XXA-N0SN	
KKB INDUSTRIAL PRECISION CO., LIMITED				WEIGHT	SHEET	REVISION
				1.0g	1/1	A0

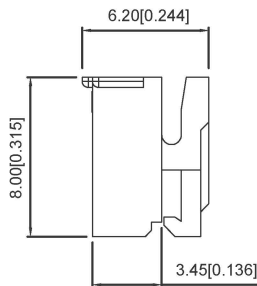
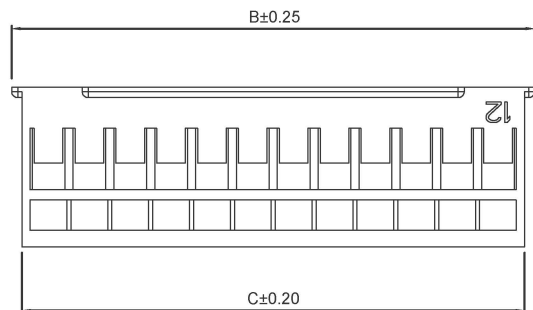
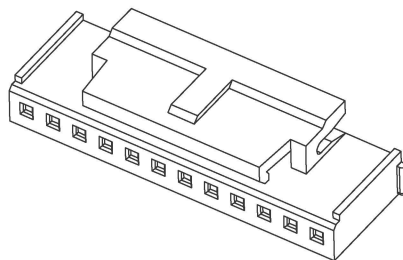
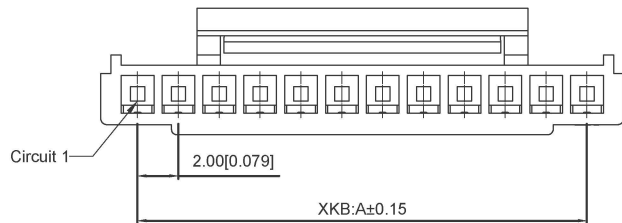

3P~16P Shape
Scale 1:1

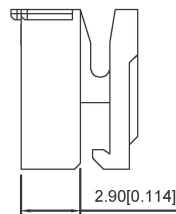

2P Shape
Scale 1:1

Specifications:

规格:
 Voltage rating:250V AC/DC
 额定电压: 250V AC/DC
 Current rating:3A AC/DC
 额定电流: 3A AC/DC
 Withstanding voltage:1000V AC/minute
 耐受电压: 1000V AC/分钟
 Temperature range:-25℃~+85℃
 温度范围: -25℃~+85℃
 Insulation resistance:≥1000MΩ
 绝缘电阻: ≥1000MΩ
 Contact resistance:≤30mΩ
 接触电阻: ≤30mΩ
 After environmental testing:≤40mΩ
 环境测试后: ≤40兆欧

X2011 H X-XX A-N0 XX XX

① ② ③ ④ ⑤ ⑥ ⑦ ⑧

- 1.Series No
- 2.Category:H-HSG
- 3.Appearance type:Blank-Ordinary
- 4.Row No-Pin No:XX-02P~16P
- 5.Plug the Pin&Special N0:A-With Lock
- 6.Material:N0-PA66 UL 94V-0
- 7.Color:Blank-Natural Color
BK-Black
- 8.Whether containing halogen:
HF-Halogen free
Blank-Containing halogen

poles	Dimensions(mm)			poles	Dimensions(mm)		
	A	B	C		A	B	C
2	2.00	5.60	4.60	10	18.00	21.60	20.60
3	4.00	7.60	6.60	11	20.00	23.60	22.60
4	6.00	9.60	8.60	12	22.00	25.60	24.60
5	8.00	11.60	10.60	13	24.00	27.60	26.60
6	10.00	13.60	12.60	14	26.00	29.60	28.60
7	12.00	15.60	14.60	15	28.00	31.60	30.60
8	14.00	17.60	16.60	16	30.00	33.60	32.60
9	16.00	19.60	18.60				

X2011H-XXA-N0BK	PA66 UL 94V-0 Black	X2011T-A	X2011W-A
X2011H-XXA-N0	PA66 UL 94V-0		
PART NO	Material	Suitable XKB Terminal	Suitable XKB Terminal



广东星坤科技股份有限公司

生	日期
效	
文件	工程章

REVISIONS

DATE	REVISED	APPROVED	units:	mm
			tolerance:	
			X.X	±0.2mm
			X.XX	±0.1mm
			X.XXX	±0.05mm

UNSPECIFIED TOLERANCES

DSND		DATE		SCALE: N/A	MODEL TYPE: Wire to board connector
DWN		DATE		VIEW:	PART NO.:
CHKD		DATE		UNIT: mm/in	2.00mm Crimp Style Connectors
APPD		DATE		SIZE: A4	DWG NO.: X2011H-XXA-N0
XKB INDUSTRIAL PRECISION CO. LIMITED				WEIGHT	SHEET
				REVISION	

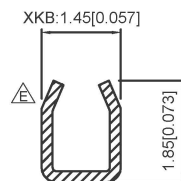
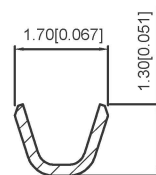
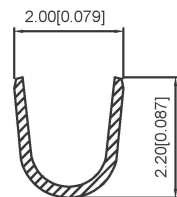
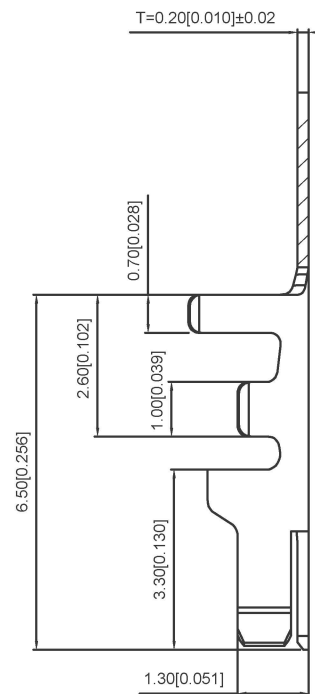
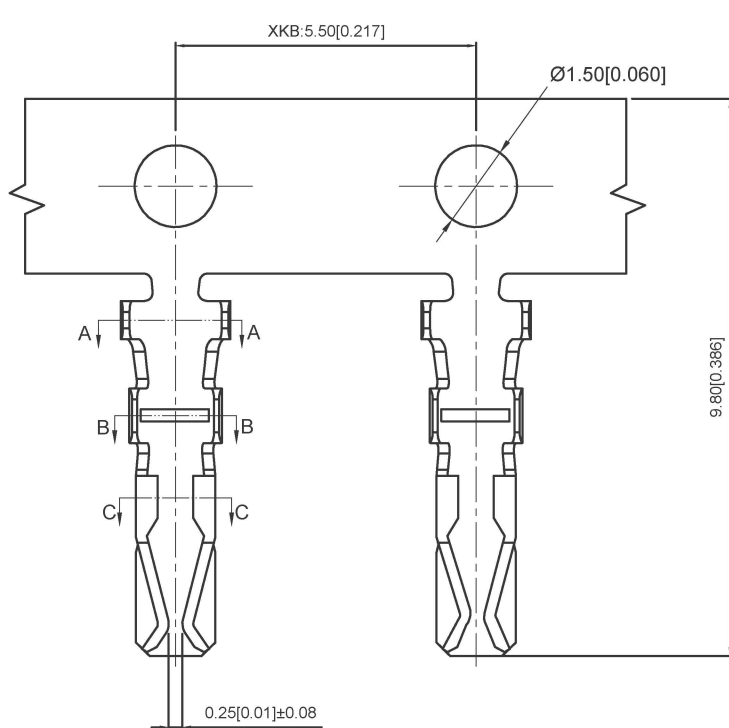

Specifications:
 规格:
 Voltage rating: 250V AC/DC
 额定电压: 250V AC/DC
 Current rating: 3A AC/DC
 额定电流: 3A AC/DC
 Withstanding voltage: 1000V AC/minute
 耐受电压: 1000V AC/分钟

Temperature range: -25°C ~ +85°C
 温度范围: -25°C ~ +85°C
 Insulation resistance: ≥1000MΩ
 绝缘电阻: ≥1000MΩ
 Contact resistance: ≤30mΩ
 接触电阻: ≤30mΩ
 After environmental testing: ≤40mΩ
 环境测试后: ≤40兆欧

X2011 T X - P SN X - A

① ② ③ ④ ⑤ ⑥ ⑦

1. Series Number
2. Category: T-terminal
3. Shape: Blank-ordinary
4. Material: P-Phosphor bronze
5. Plating style: SN-Bright tin plating
6. Plating method: Blank-Stamping before plating
7. Mold No/Mark/Special No: A-Mating 2011-A HSG

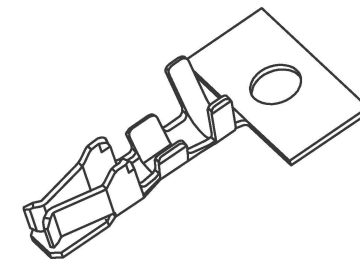

X2011T-PSN-A	Phosphor Bronze	AWG#22-30	1.45mm(MAX)	Stamping Before Plating: 30u"MIN. Ni; 70u"MIN. Sn	X2011H-A
PART NO	Material	Wire Range	Insulation OD	Finish	Suitable XKB Terminal

广东星坤科技股份有限公司

SECTION: A-A
SCALE: 1:1

SECTION: B-B
SCALE: 1:1

SECTION: C-C
SCALE: 1:1

生	日期
ΔX	日期
ΔX	日期
ΔX	日期
MARK	文件工程章

units:	mm
tolerance:	
X.X	±0.2mm
X.XX	±0.1mm
X.XXX	±0.05mm
	UNSPECIFIED TOLERANCES

DSND		DATE		SCALE: N/A	MODEL TYPE: Wire to board connector
DWN		DATE		VIEW:	PART NO.:
CHKD		DATE		UNIT: mm/in	2.00mm Crimp Style Connectors
APPD		DATE		SIZE: A4	DWG NO.: X2011T-PSN-A
XKB INDUSTRIAL PRECISION CO., LIMITED					WEIGHT 1.0g
					SHEET 1/1
					REVISION A0