

PART NUMBER	REVISION	DESCRIPTION	FEED TYPE
2150177-1	E	FINE CRIMP HEIGHT ADJUST	MECHANICAL
2150177-2	F	FINE CRIMP HEIGHT ADJUST	PNEUMATIC
7-2150177-1	E	MECHANICAL AND CRIMP TOOLING KIT	MECHANICAL
7-2150177-2	F	PNEUMATIC AND CRIMP TOOLING KIT	PNEUMATIC
7-2150177-7	A	CRIMP TOOLING KIT	-

ATLANTIC VERSION TERMINATOR INTERFACE ADAPTER

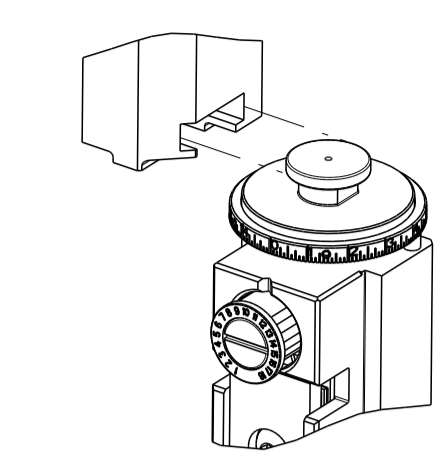

APPLICATOR DATA		
CRIMP	SIZE	TYPE
WIRE	2.79 mm [.110]	F
INSUL	4.57 mm [.180]	F

APPLICATOR INSTRUCTIONS
408-35043

TERMINAL DATA: TE TERMINAL		TE CRIMP SPECIFICATION	
TERMINAL NAME: RECEPTACLE, POSITIVE-LOCK, .250 SERIES			
WIRE STRIP LENGTH		INSULATION DIAMETER RANGE	
4.30-5.10 mm [.169-.201 IN]		∅2.29-3.94 mm [.090-.155 IN]	
TERMINAL APPLICATION SPECIFICATION	114-2074		
TERMINALS APPLIED			
TE TERMINAL	TE TERMINAL	TE TERMINAL	TE TERMINAL
1217094-1	1217094-2	2238135-1	2238135-2

WIRE SIZE	CRIMP HEIGHT mm [INCH]	CRIMP HEIGHT REFERENCE SETTING
14 AWG	1.57+/-0.05 [.062+/-0.002]	4.5
16 AWG	1.37+/-0.05 [.054+/-0.002]	7.0
18 AWG	1.24+/-0.05 [.049+/-0.002]	8.5

- 1 RECOMMENDED SPARE PARTS
- 2 REFER TO SUPPLIED INSTRUCTION SHEET FOR CLEANING, LUBRICATION AND STORAGE OF APPLICATOR.
- 3 APPLY PART NUMBER 1-23419-5 LOCTITE TO THREADS OF ITEM 180. APPLY PART NUMBER 2-23419-6 LOCTITE TO THREADS OF ITEM 242.
- 4 CRIMP HEIGHT REFERENCE SETTING WAS THE SETTING USED WHEN THE APPLICATOR WAS QUALIFIED AT THE FACTORY. ADJUSTMENT MAY BE NECESSARY WHEN RUNNING APPLICATOR IN THE FIELD.
- 5. UNLESS SPECIFIED OTHERWISE TORQUE VALUES SHALL BE USED PER DOCUMENT, 101-35000.

***WARNING**
ON INSTALLATION, SET WIRE DISC TO CRIMP HEIGHT REFERENCE SETTING FOR LARGEST WIRE SIZE. CRIMP HEIGHT REFERENCE SETTINGS GREATER THAN THE VALUE SHOWN MAY CAUSE DAMAGE TO THE CRIMP TOOLING, REFER TO THE INSTRUCTION SHEET FOR PROPER SETUP AND ADJUSTMENTS.

ATLANTIC VERSION
Shown on sheets 1 of 4 & 2 of 4
(Pacific version shown on sheets 3 of 4 & 4 of 4)

LOC	DIST	REVISIONS					
A	66	P	LTN	DESCRIPTION	DATE	DWN	APVD
		D		ECR-18-017991	15NOV2018	JAH	CT
		E		ECR-19-000115	04JAN2019	FL	CT
		E1		ECR-20-006089	27APR2020	FZ	RK
		F		ECR-22-127089	19JAN2022	JWC	RK

-	1	-	1	-	2119641-1	FEED CAM, AIR FEED	248	
-	1	1	1	1	2119082-9	CAM, SNAIL, INSULATION ADJUSTMENT	244	
-	1	1	1	1	2079764-1	WASHER, WAVE SPRING, CREST-TO-CREST	243	
-	1	1	1	1	2119083-1	RETAINER, INSULATION DIAL	242	
-	-	1	-	1	2119580-1	MECHANICAL FEED ASSEMBLY	239	
-	1	-	1	-	2844940-3	AIR FEED MODULE	238	
-	1	1	1	1	1-18028-0	WASHER, FLAT, REG M8	192	
-	1	1	1	1	1-1752354-0	STANDOFF, HOLD-DOWN	180	
-	1	1	1	1	6-993111-6	PIN, SLOTTED SPRING 3.0 X 14.0	177	
-	1	1	1	1	8-22280-7	SPRING, COMPRESSION	176	
-	1	1	1	1	1752353-2	GUIDE PIN, HOLDDOWN	175	
-	1	1	1	1	1901680-2	GUIDE PIN, HOLDDOWN	174	
-	REF	REF	REF	REF	994970-2	COUNTER, MAGNETIC	164	
-	1	1	1	1	455888-5	SPACER, CRIMPER	82	
-	1	1	1	1	1803607-4	DOCUMENTATION PACKAGE	71	
-	2	2	2	2	2-18032-2	SCR, SET, FLT PNT, M3 X 10.0	70	
-	1	1	1	1	2119740-1	TAG, IDENTIFICATION	67	
-	2	2	2	2	2168078-1	SCREW, DRIVE, RH, RoHS, 2 x .188	66	
-	1	1	1	1	1901681-1	HOLDDOWN, TERMINAL	65	
-	1	1	1	1	2168083-2	SCR, SKT HD CAP, RoHS, M4 X 8.0	60	
-	1	1	1	1	5-18022-5	SCR, HEX HD CAP, M4 X 6.0	59	
-	-	1	-	1	2063961-1	FEED FINGER	58	
-	4	4	4	4	2168400-4	SHCS, LOW HEAD, RoHS, M4 X 8	57	
-	2	2	2	2	2168083-8	SCR, SKT HD CAP, RoHS, M4 X 16	56	
-	2	2	2	2	5018030-1	NUT, HEX, REG, RoHS, M3	54	
-	2	2	2	2	986965-8	NUT, LOCK, HEX, TORQUE (M4)	53	
-	1	1	1	1	1-5018030-0	NUT, HEX, REG, RoHS, M3.5	52	
-	1	-	1	-	2063961-1	FEED FINGER	51	
-	1	2	1	2	18023-9	SCR, SKT HD CAP M4 X 6.0	49	
-	-	1	-	1	2119652-1	FEED CAM, PRE FEED	48	
-	-	1	-	1	2119653-1	FEED CAM, POST FEED	47	
-	1	1	1	1	2119655-5	APPLICATOR BASIC ASSEMBLY, EF	46	
-	1	1	1	1	1803517-1	RAM ASSEMBLY, EF ATLANTIC	44	
-	1	1	1	1	1803602-1	SCR, BHSC, RoHS (M8 X 25)	41	
-	8	8	8	8	1-18028-2	WASHER, FLAT, REG M4	33	
-	2	2	2	2	2168083-9	SCR, SKT HD CAP, RoHS, M4 X 20	31	
-	2	2	2	2	1-2168083-0	SCR, SKT HD CAP, RoHS, M4 X 10	29	
-	1	1	1	1	240639-1	STRIPPER (MACHINING)	27	
-	2	2	2	2	1-2168083-5	SCR, SKT HD CAP, RoHS, M4 X 30	25	
-	1	1	1	1	1752371-1	PLATE, STRIP GUIDE	24	
-	2	2	2	2	2-22281-3	SPRING, COMPRESSION	22	
-	1	1	1	1	1803292-1	DRAG	20	
-	2	2	2	2	1-1901259-0	GUIDE, LOWER STRIP	18	
-	4	4	4	4	1-2079383-1	SCR, BHSC, RoHS (M6 X 12)	17	
-	1	1	1	1	240641-1	SPACER	16	
-	1	1	1	1	1752360-1	SPACER, HOLD-DOWN	13	
-	1	1	1	1	240644-1	PLATE, REAR SHEAR	11	
-	1	1	1	1	690482-4	PLATE, FRONT SHEAR	9	
-	1	2	2	1	1	1633386-2	ANVIL, COMBINATION	8
-	1	1	1	1	1	1-690474-7	BLADE, SLUG	7
-	1	1	1	1	1	2-240641-4	SPACER	5
-	1	1	1	1	1	238011-2	BLOCK, CRIMPER SPACER	4
-	1	2	2	1	1	2119582-3	CRIMPER, INSULATION F PREMIUM	3
-	1	1	1	1	1	455888-4	SPACER, CRIMPER	2
-	1	2	2	1	1	456408-3	CRIMPER, WIRE PREMIUM	1
-	77-72-71	-	2	-	1	PART NO	DESCRIPTION	ITEM NO

DIMENSIONS:		TOLERANCES UNLESS OTHERWISE SPECIFIED:		MATERIAL:		FINISH:	
mm	0 PLC	±					
	1 PLC	±					
	2 PLC	±					
	3 PLC	±					
	4 PLC	±					
	ANGLES	±					
	FINISH						

DWN	L. ZHANG	24FEB2012	TE Connectivity Harrisburg, PA 17105-3608
CHK	L. ZHANG	24FEB2012	
APVD	S. XI	24FEB2012	NAME
PRODUCT SPEC			Ocean End Feed Applicator
APPLICATION SPEC			
SIZE	CAGE CODE	DRAWING NO	RESTRICTED TO
A1	00779	2150177	
Customer Accessible Production Drawing			SCALE 1:1 SHEET 1 OF 4 REV F

LOC	DIST	REVISIONS					
A	66	P	LTN	DESCRIPTION	DATE	OWN	APVD
		-		SEE SHEET 1			

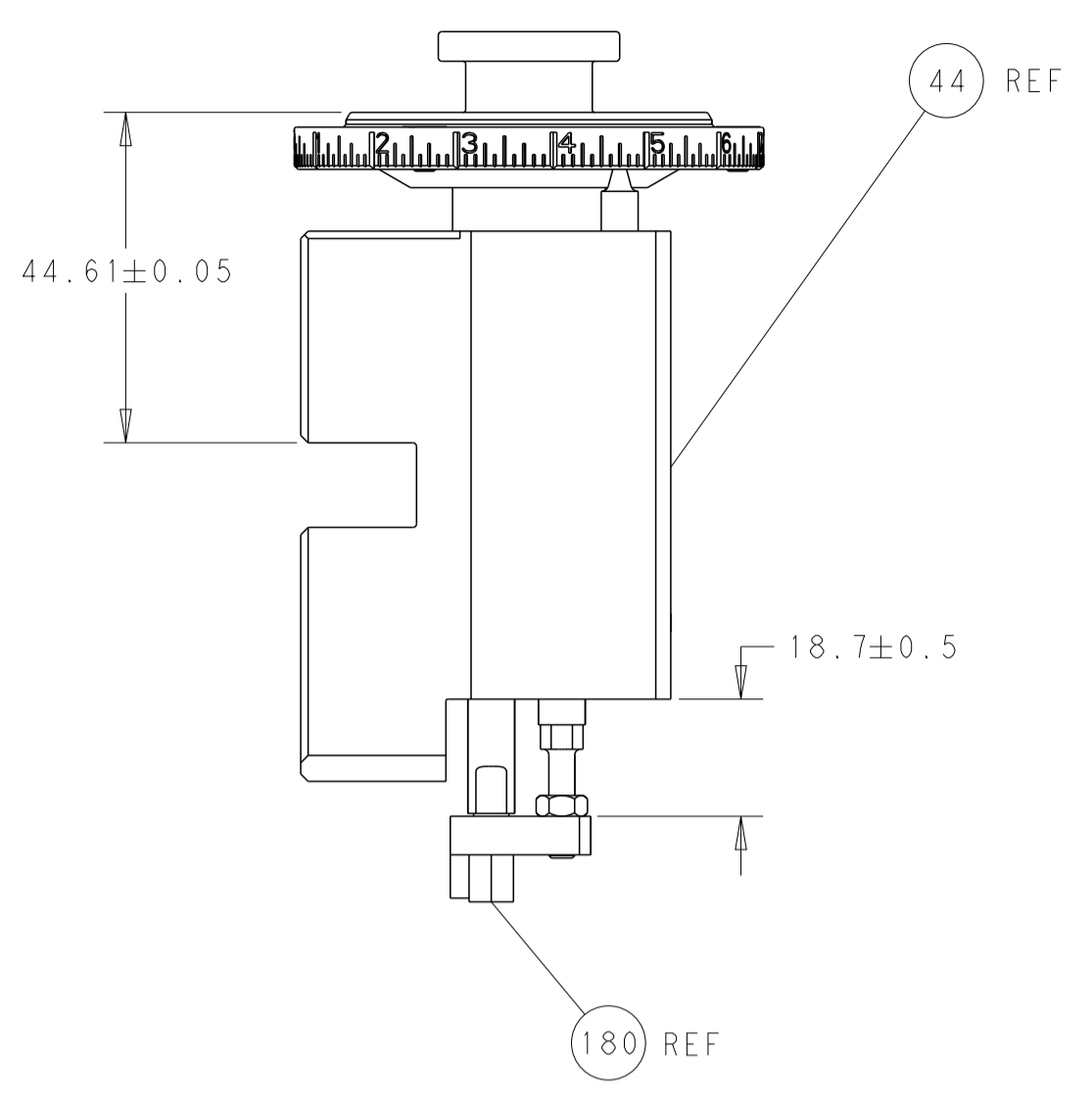

RAM AND HOLDDOWN SET-UP

FEED TYPE
MECHANICAL

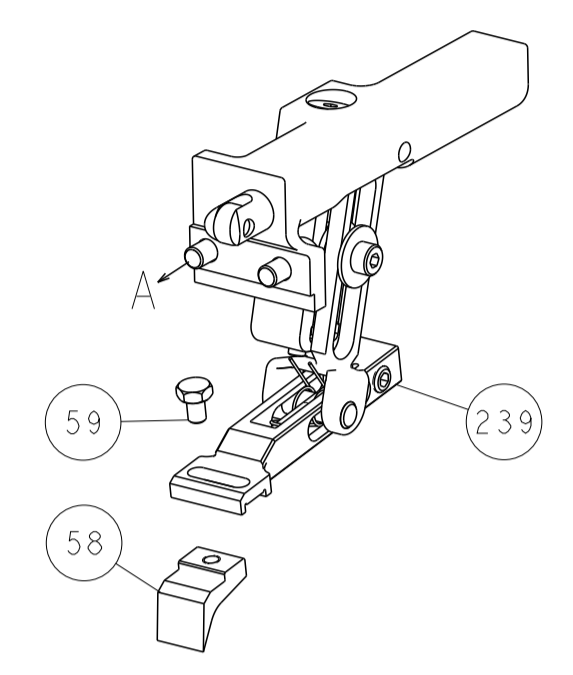

PNEUMATIC

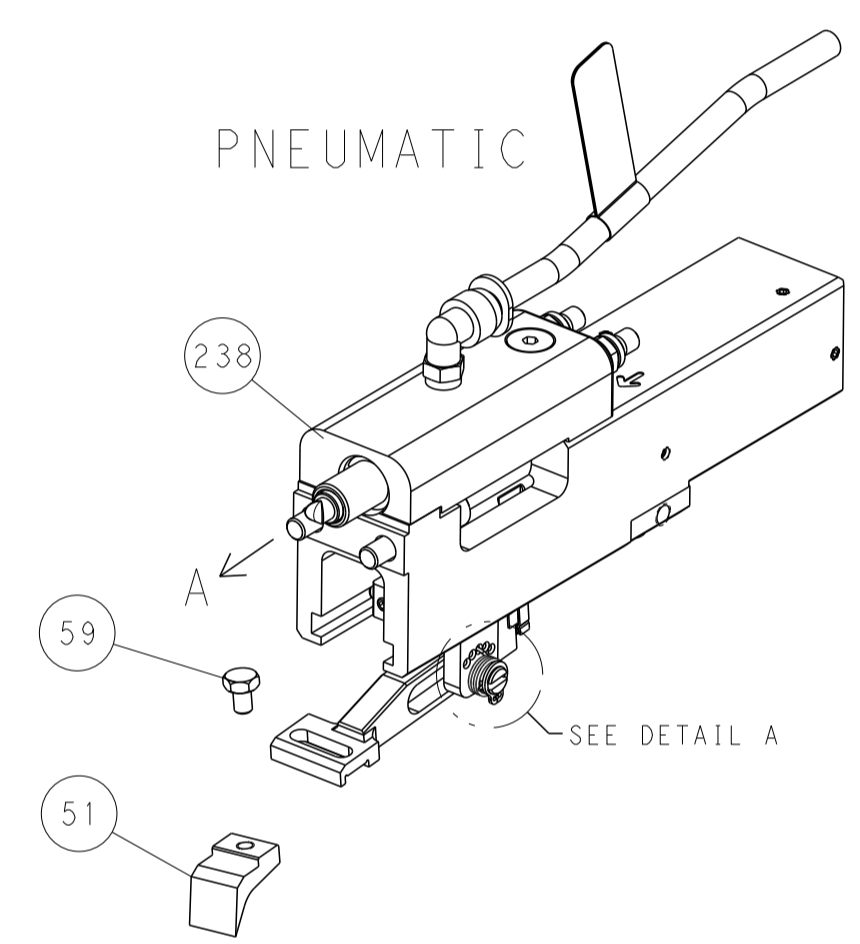

FEED SPRING
SETTING POSITION

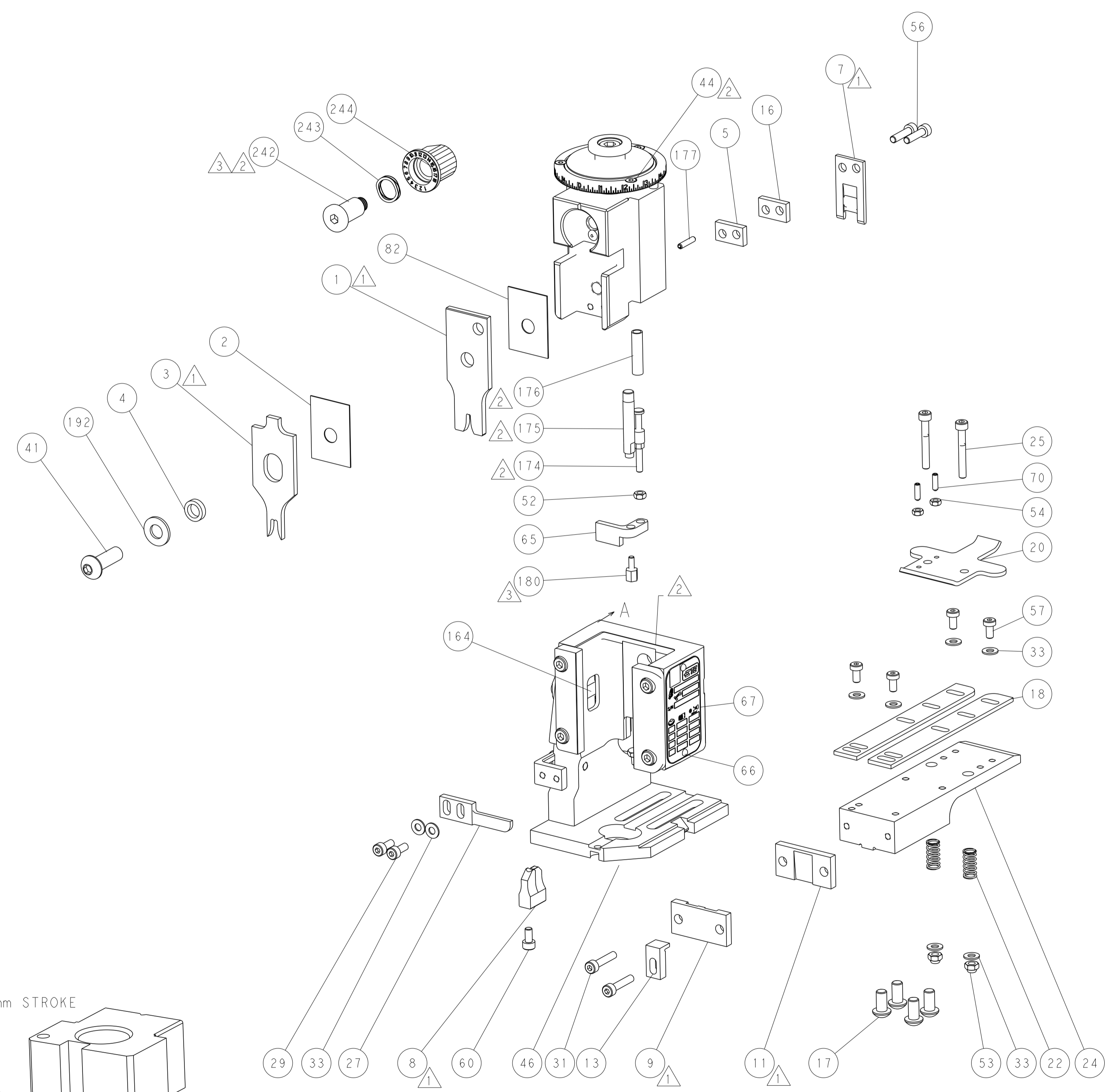
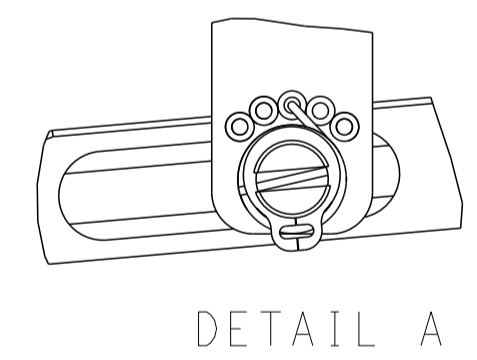

CAM POSITIONS

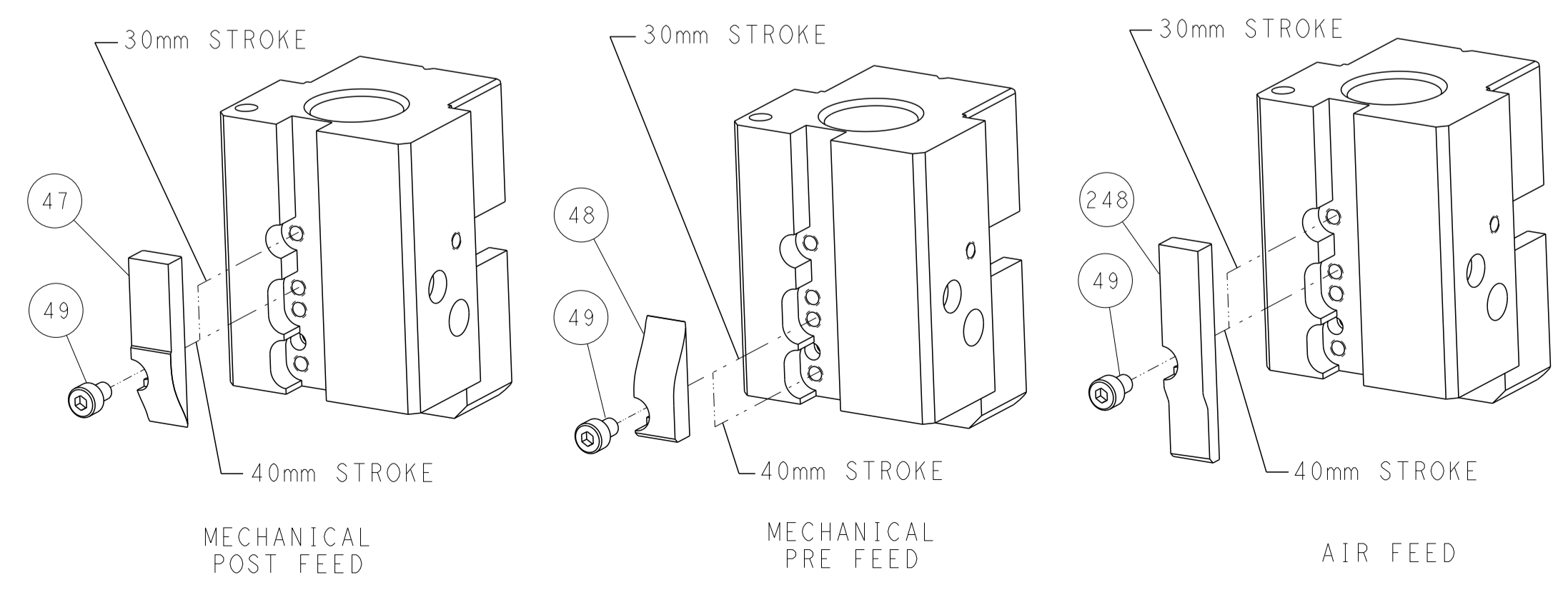

ATLANTIC VERSION
 Shown on sheets 1 of 4 & 2 of 4
 (Pacific version shown on sheets 3 of 4 & 4 of 4)

DIMENSIONS:		TOLERANCES UNLESS OTHERWISE SPECIFIED:		OWN		TE Connectivity	
mm	0 PLC ±	1 PLC ±	2 PLC ±	3 PLC ±	4 PLC ±	5 PLC ±	6 PLC ±
	ANGLES	FINISH		NAME		RESTRICTED TO	
MATERIAL		WEIGHT	SCALE	SHEET	OF	REV	
			1:1	2	4	F	

PART NUMBER	REVISION	DESCRIPTION	FEED TYPE
2-2150177-1	E	FINE CRIMP HEIGHT ADJUST	MECHANICAL
2-2150177-2	F	FINE CRIMP HEIGHT ADJUST	PNEUMATIC
7-2150177-7	A	CRIMP TOOLING KIT	-

PACIFIC VERSION TERMINATOR
INTERFACE ADAPTER

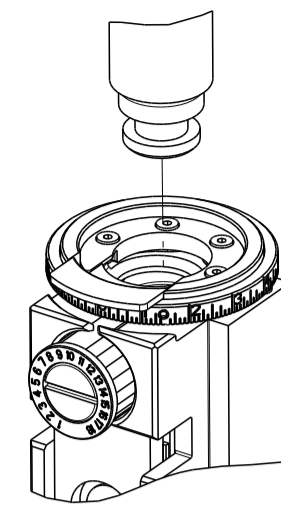

APPLICATOR DATA		
CRIMP	SIZE	TYPE
WIRE	2.79 mm (.110)	F
INSUL	4.57 mm (.180)	F
APPLICATOR INSTRUCTIONS 408-35043		

TERMINAL DATA: TE TERMINAL TE CRIMP SPECIFICATION			
TERMINAL NAME: RECEPTACLE, POSITIVE-LOCK, .250 SERIES			
WIRE STRIP LENGTH		INSULATION DIAMETER RANGE	
4.30-5.10 mm (.169-.201 IN)		∅2.29-3.94 mm (.090-.155 IN)	
TERMINAL APPLICATION SPECIFICATION	114-2074	-	-
TERMINALS APPLIED			
TE TERMINAL	TE TERMINAL	TE TERMINAL	TE TERMINAL
1217094-1	1217094-2	2238135-1	2238135-2

WIRE SIZE	CRIMP HEIGHT mm [INCH]	CRIMP HEIGHT REFERENCE SETTING
14 AWG	1.57 +/- 0.05 [.062 +/- .002]	4.5
16 AWG	1.37 +/- 0.05 [.054 +/- .002]	7.0
18 AWG	1.24 +/- 0.05 [.049 +/- .002]	8.5

- RECOMMENDED SPARE PARTS
- REFER TO SUPPLIED INSTRUCTION SHEET FOR CLEANING, LUBRICATION AND STORAGE OF APPLICATOR.
- APPLY PART NUMBER 1-23419-5 LOCTITE TO THREADS OF ITEM 180. APPLY PART NUMBER 2-23419-6 LOCTITE TO THREADS OF ITEM 242.
- CRIMP HEIGHT REFERENCE SETTING WAS THE SETTING USED WHEN THE APPLICATOR WAS QUALIFIED AT THE FACTORY. ADJUSTMENT MAY BE NECESSARY WHEN RUNNING APPLICATOR IN THE FIELD.
- 5. UNLESS SPECIFIED OTHERWISE TORQUE VALUES SHALL BE USED PER DOCUMENT, 101-35000.

***WARNING**
ON INSTALLATION, SET WIRE DISC TO CRIMP HEIGHT REFERENCE SETTING FOR LARGEST WIRE SIZE. CRIMP HEIGHT REFERENCE SETTINGS GREATER THAN THE VALUE SHOWN MAY CAUSE DAMAGE TO THE CRIMP TOOLING, REFER TO THE INSTRUCTION SHEET FOR PROPER SETUP AND ADJUSTMENTS.

PACIFIC VERSION
Shown on sheets 3 of 4 & 4 of 4
(Atlantic version shown on sheets 1 of 4 & 2 of 4)

LOC	DIST	REVISIONS					
A	66	P	LTN	DESCRIPTION	DATE	OWN	APVD
-	-	-	-	SEE SHEET 1	-	-	-

-	1	1	2119082-9	CAM, SNAIL, INSULATION ADJUSTMENT	244	
-	1	1	2079764-1	WASHER, WAVE SPRING, CREST-TO-CREST	243	
-	1	1	2119083-1	RETAINER, INSULATION DIAL	242	
-	-	1	2119580-1	MECHANICAL FEED ASSEMBLY	239	
-	1	-	2844940-3	AIR FEED MODULE	238	
-	1	1	1-18028-0	WASHER, FLAT, REG M8	192	
-	4	4	2079383-9	SCR, BHSC, RoHS (M6 X 20)	186	
-	1	1	1-1752354-0	STANDOFF, HOLD-DOWN	180	
-	1	1	6-993111-6	PIN, SLOTTED SPRING 3.0 X 14.0	177	
-	1	1	8-22280-7	SPRING, COMPRESSION	176	
-	1	1	1752353-2	GUIDE PIN, HOLDDOWN	175	
-	1	1	1901680-2	GUIDE PIN, HOLDDOWN	174	
-	REF	REF	994970-2	COUNTER, MAGNETIC	164	
-	1	-	2119641-2	FEED CAM, AIR FEED	152	
-	1	1	2168083-8	SCR, SKT HD CAP, RoHS, M4 X 16	144	
-	-	1	2119653-2	FEED CAM, POST FEED	142	
-	1	1	2119655-6	APPLICATOR BASIC ASSEMBLY, EF	141	
-	1	1	1803518-1	RAM ASSEMBLY, EF PACIFIC	140	
-	1	1	455888-5	SPACER, CRIMPER	82	
-	1	1	1803607-4	DOCUMENTATION PACKAGE	71	
-	2	2	2-18032-2	SCR, SET, FLT PNT, M3 X 10.0	70	
-	1	1	2119740-1	TAG, IDENTIFICATION	67	
-	2	2	2168078-1	SCREW, DRIVE, RH, RoHS, 2 x .188	66	
-	1	1	1901681-1	HOLDDOWN, TERMINAL	65	
-	1	1	5-18022-5	SCR, HEX HD CAP, M4 X 6.0	59	
-	-	1	2063961-1	FEED FINGER	58	
-	4	4	2168400-4	SHCS, LOW HEAD, RoHS, M4 X 8	57	
-	2	2	2168083-8	SCR, SKT HD CAP, RoHS, M4 X 16	56	
-	2	2	5018030-1	NUT, HEX, REG, RoHS, M3	54	
-	2	2	986965-8	NUT, LOCK, HEX, TORQUE (M4)	53	
-	1	1	1-5018030-0	NUT, HEX, REG, RoHS, M3.5	52	
-	1	-	2063961-1	FEED FINGER	51	
-	1	2	18023-9	SCR, SKT HD CAP M4 X 6.0	49	
-	-	1	2119652-1	FEED CAM, PRE FEED	48	
-	1	1	1803602-1	SCR, BHSC, RoHS (M8 X 25)	41	
-	8	8	1-18028-2	WASHER, FLAT, REG M4	33	
-	2	2	2168083-9	SCR, SKT HD CAP, RoHS, M4 X 20	31	
-	2	2	1-2168083-0	SCR, SKT HD CAP, RoHS, M4 X 10	29	
-	1	1	240639-1	STRIPPER (MACHINING)	27	
-	2	2	1-2168083-5	SCR, SKT HD CAP, RoHS, M4 X 30	25	
-	1	1	1752371-1	PLATE, STRIP GUIDE	24	
-	2	2	2-22281-3	SPRING, COMPRESSION	22	
-	1	1	1803292-1	DRAG	20	
-	2	2	1-1901259-0	GUIDE, LOWER STRIP	18	
-	1	1	240641-1	SPACER	16	
-	1	1	1752360-1	SPACER, HOLD-DOWN	13	
-	1	1	240644-1	PLATE, REAR SHEAR	11	
-	1	1	690482-4	PLATE, FRONT SHEAR	9	
1	1	1	1633386-2	ANVIL, COMBINATION	8	
-	1	1	1-690474-7	BLADE, SLUG	7	
-	1	1	2-240641-4	SPACER	5	
-	1	1	238011-2	BLOCK, CRIMPER SPACER	4	
1	1	1	2119582-3	CRIMPER, INSULATION F PREMIUM	3	
-	1	1	455888-4	SPACER, CRIMPER	2	
1	1	1	456408-3	CRIMPER, WIRE PREMIUM	1	
-	77	22	21	PART NO	DESCRIPTION	ITEM NO

DIMENSIONS:		TOLERANCES UNLESS OTHERWISE SPECIFIED:		DRAWING NO	
mm	0 PLC ±	1 PLC ±	2 PLC ±	3 PLC ±	4 PLC ±
mm	ANGLES ±	FINISH			
MATERIAL					
Customer Accessible Production Drawing		SCALE	1:1	SHEET	3 OF 4

LOC	DIST	REVISIONS					
A	66	P	LTM	DESCRIPTION	DATE	OWN	APVD
		-		SEE SHEET 1			

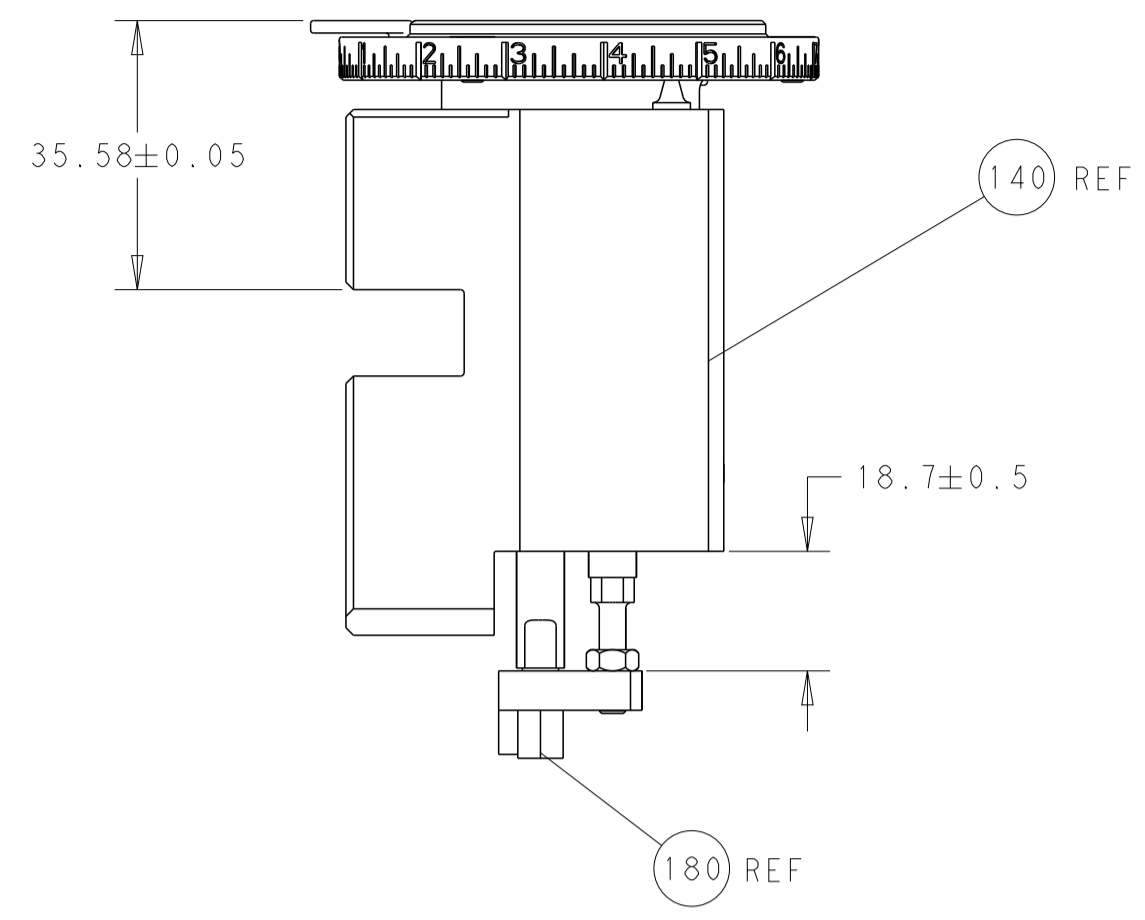

RAM AND HOLDDOWN SET-UP

FEED TYPE
MECHANICAL

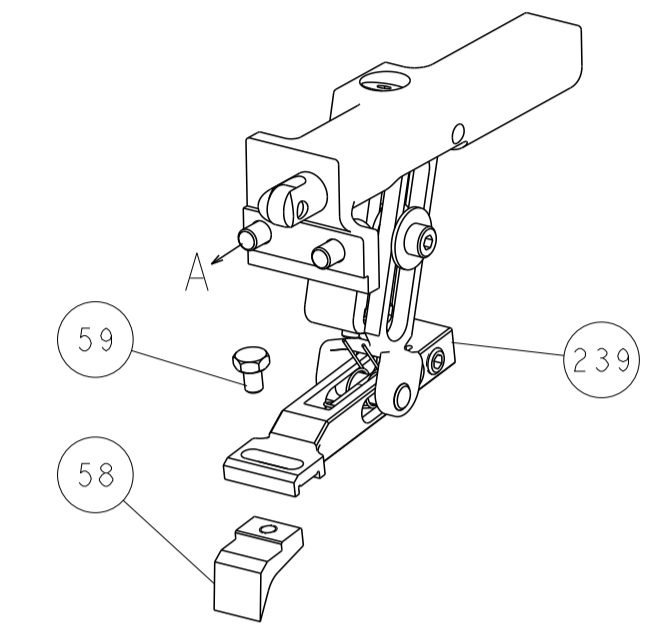

PNEUMATIC

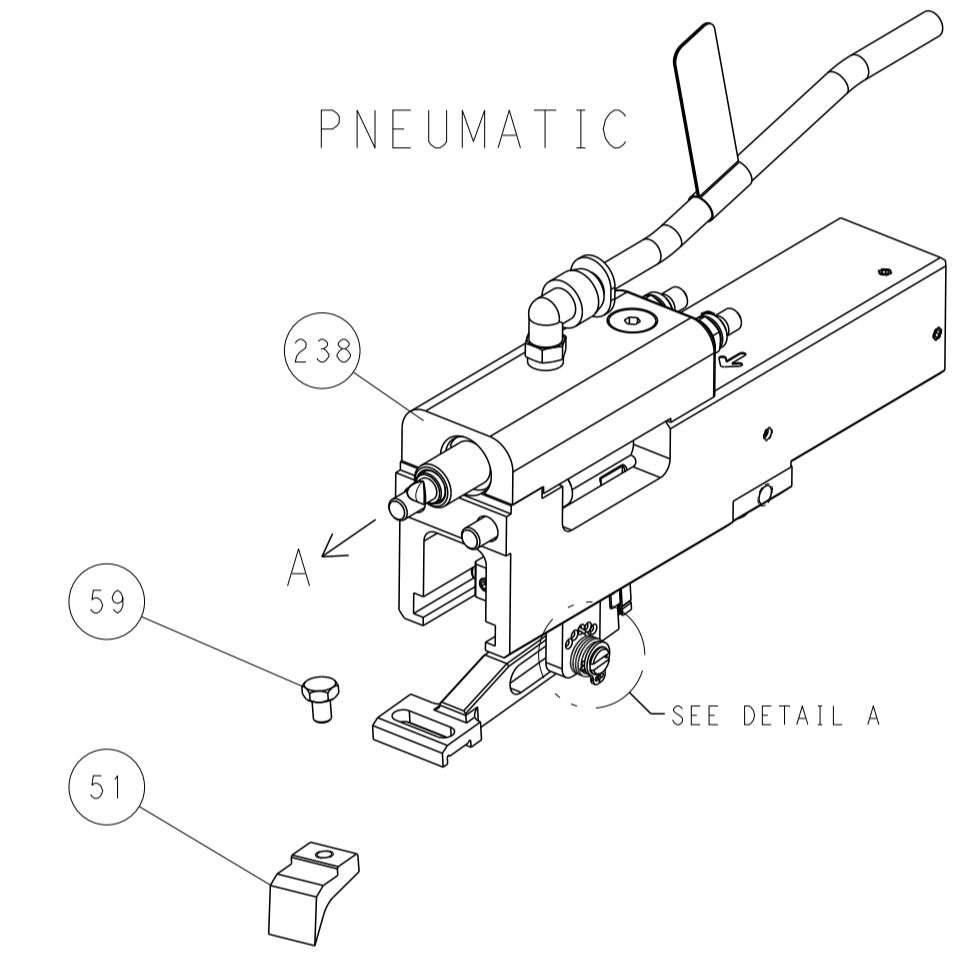

FEED SPRING
SETTING POSITION

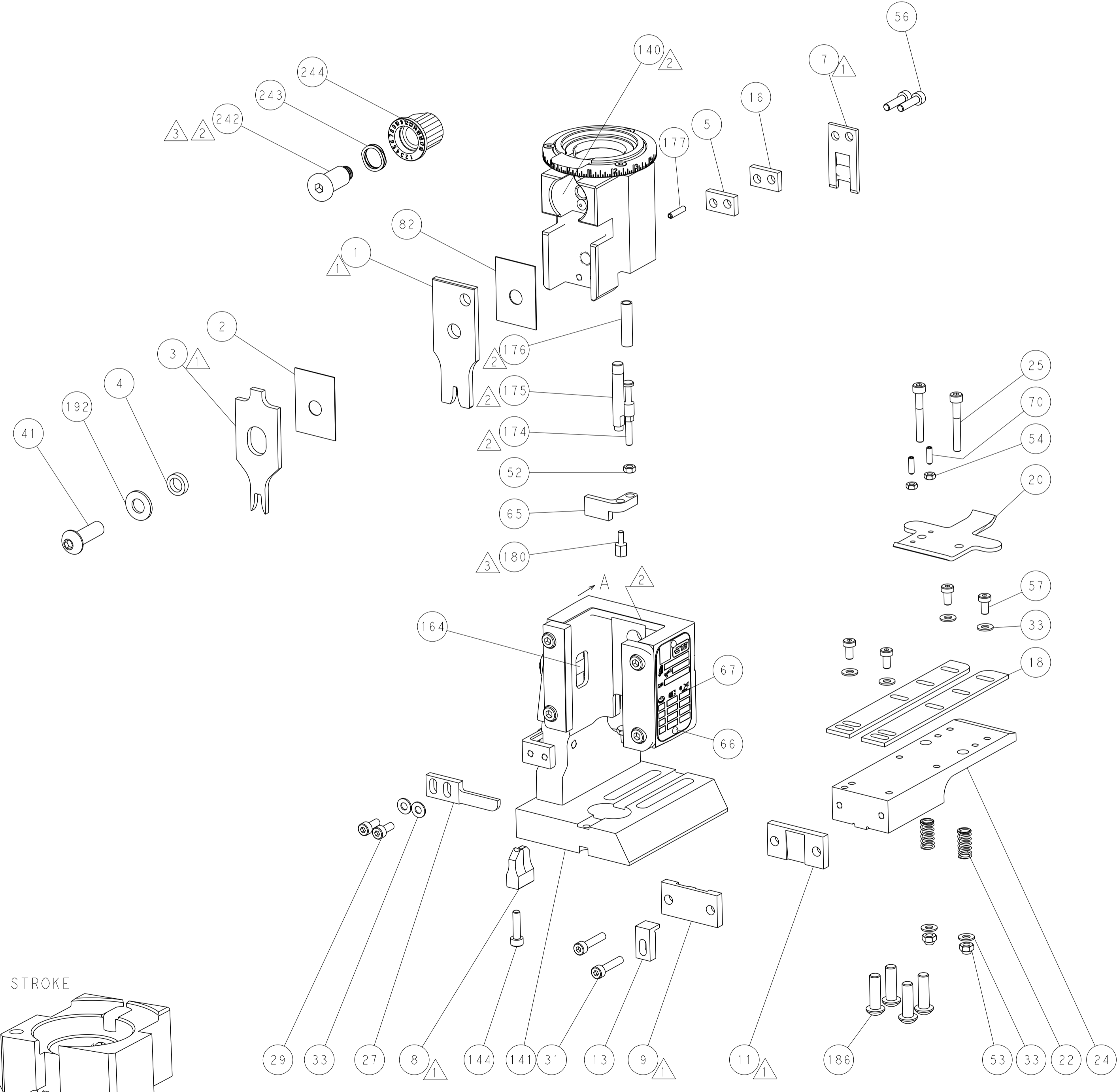
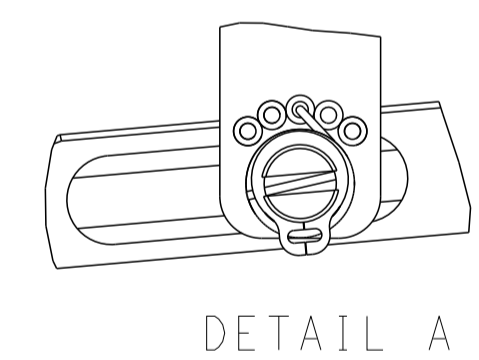

CAM POSITIONS

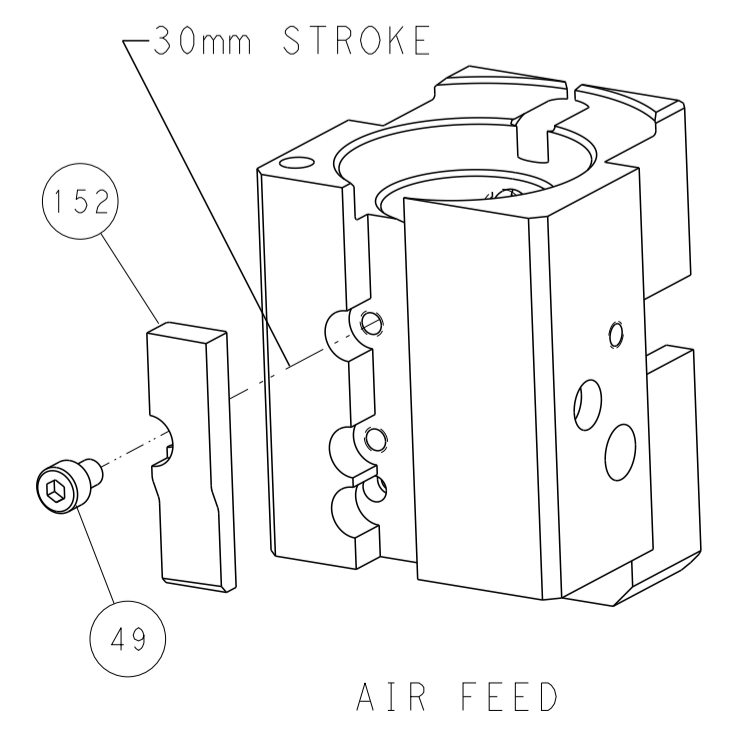
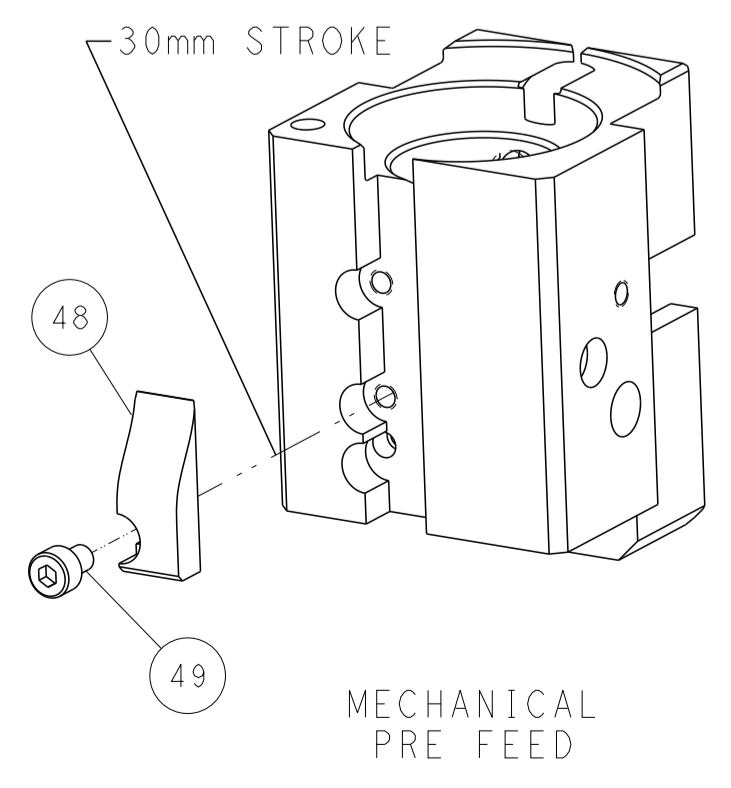
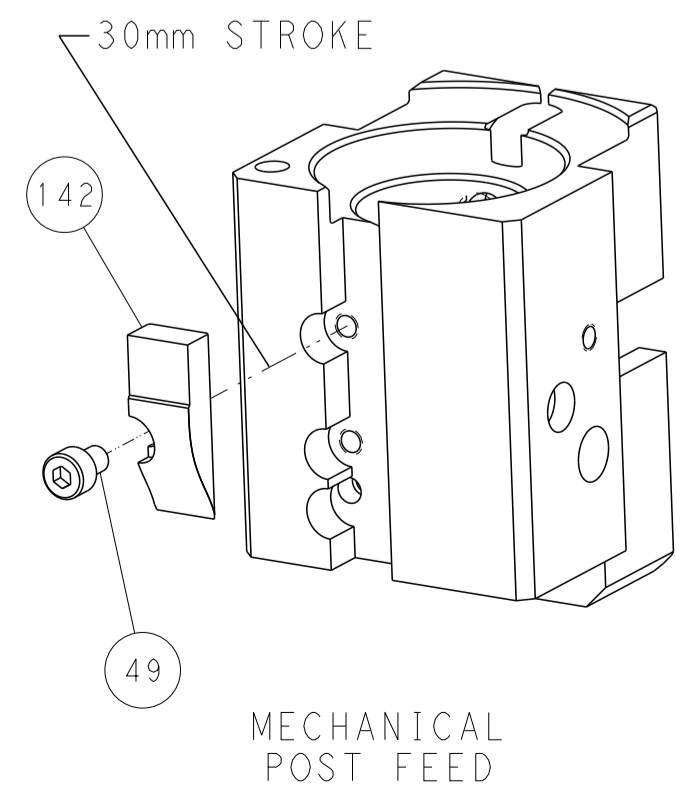

PACIFIC VERSION
 Shown on sheets 3 of 4 & 4 of 4
 (Atlantic version shown on sheets 1 of 4 & 2 of 4)

DIMENSIONS: mm 		TOLERANCES UNLESS OTHERWISE SPECIFIED: 0 PLC ± 1 PLC ± 2 PLC ± 3 PLC ± 4 PLC ± ANGLES ± FINISH		DWN L. ZHANG 24FEB2012 CHK L. ZHANG 24FEB2012 S. XI 24FEB2012 APVD PRODUCT SPEC APPLICATION SPEC WEIGHT Customer Accessible Production Drawing		NAME Ocean End Feed Applicator SIZE CAGE CODE DRAWING NO A1 00779 C-2150177 SCALE 1:1 SHEET 4 OF 4 REV F		RESTRICTED TO	
-----------------------	--	---	--	---	--	---	--	---------------	--