

Description

The PJ75B series is a set of three-terminal low power high voltage regulators implemented in CMOS technology. They allow input voltages as high as 36V. They are available with several fixed output voltages ranging from 1.8V to 5.0V. The device features integrated short-circuit and thermal shutdown protection.

Features

- Wide input voltage range from 3V to 36V
- Up to 200mA Load Current
- Low voltage drop
- Quiescent current : 2.5 μ A
- Output voltage tolerance : \pm 2%
- Available Packages : SOT-23, SOT-23-3, SOT-89, SOT-23-5

Applications

- Battery-Powered Equipment
- Ultra Low Power Microcontrollers
- Security Monitoring Equipment

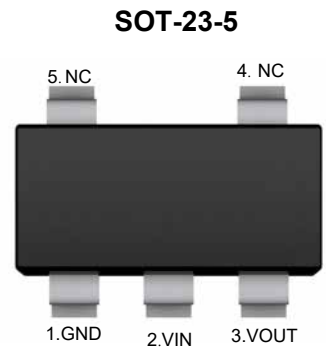
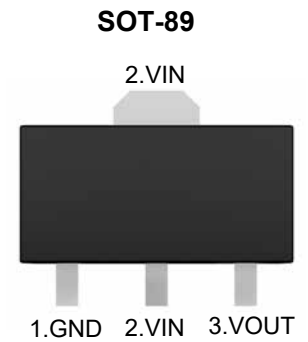



Functional Pin Description

Pin Name	Pin Function
NC	NO Connected
GND	Ground
VOUT	Output Voltage
VIN	Power Input Voltage

Marking Code ^{Note}

Output Voltage	Package	Marking Code
1.8V~5V	SOT-23	75XX
1.8V~5V	SOT-23-3	75XXC
1.8V~5V	SOT-23-5	75XXE
1.8V~5V	SOT-89	75XX

Note . XX : Output Voltage
e.g . 50:5.0V

Ordering Information

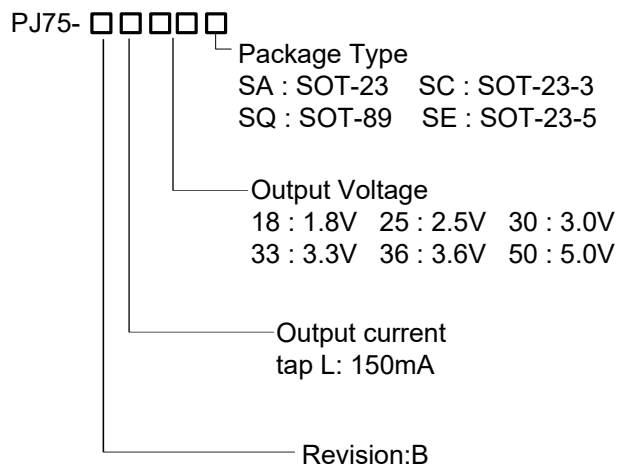

Function Block Diagram

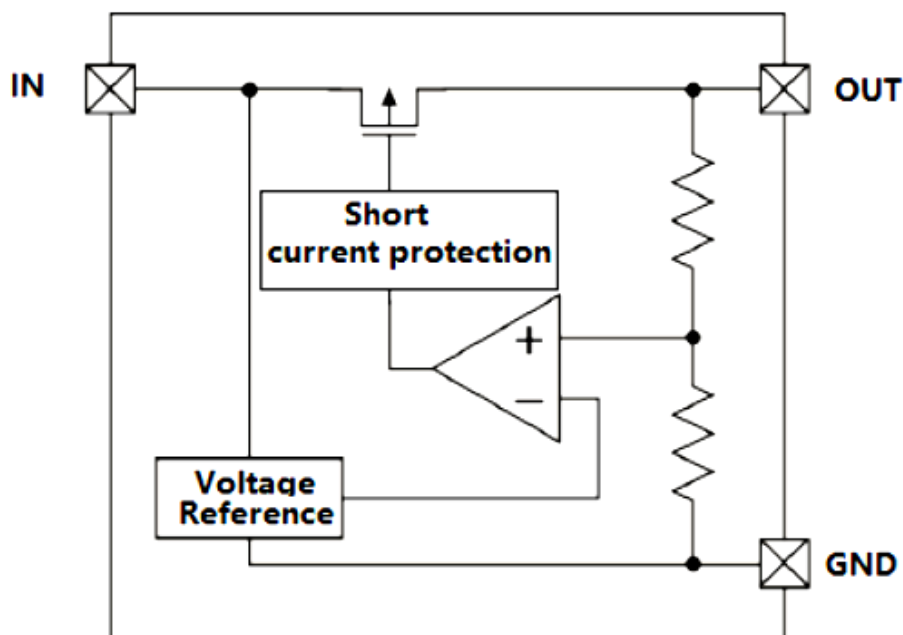

Absolute Maximum Ratings

Ratings at 25°C ambient temperature unless otherwise specified.

Parameter		Value	Unit
Supply Voltage		-0.3 ~ +40	V
Power Dissipation	SOT-23	300	mW
	SOT-23-3	400	mW
	SOT-23-5	400	mW
	SOT-89	600	mW
Thermal Resistance, Junction-to-Ambient	SOT-23	380	°C/W
	SOT-23-3	300	°C/W
	SOT-23-5	300	°C/W
	SOT-89	180	°C/W
Operating Junction Temperature		-40 ~ +125	°C
Storage Temperature Range		-65 ~ +150	°C
Lead Temperature (Soldering, 10 sec)		300	°C
ESD(HBM mode, ESDA/JEDECJS-001-2017)		+2000	V



PJ75B Series Low Dropout Regulators

Electrical Characteristics

($V_{IN}=V_{OUT}+2$, $C_{IN}=1\mu F$, $C_{OUT}=1\mu F$, $T_A=25^\circ C$, unless otherwise noted.)

Parameter	Symbol	Test Conditions	Min.	Typ.	Max.	Unit	
Input Voltage	V_{IN}		3	--	36	V	
Output Voltage Accuracy	ΔV_{OUT}	$I_{OUT}=1mA$	-2	--	+2	%	
Maximum Output Current	$I_{OUT(Max)}$		150	--	--	mA	
Quiescent Current	I_Q	$I_{OUT}=0mA$	--	2.5	4	μA	
Dropout Voltage	V_{DROP}	$V_{OUT}=1.8V$	$I_{OUT}=150mA$	--	1250	1450	mV
			$I_{OUT}=100mA$	--	880	1050	mV
		$V_{OUT}=2.5V$	$I_{OUT}=150mA$	--	1150	1350	mV
			$I_{OUT}=100mA$	--	800	1000	mV
		$V_{OUT}=3.0V$	$I_{OUT}=150mA$	--	820	960	mV
			$I_{OUT}=100mA$	--	530	700	mV
		$V_{OUT}=3.3V$	$I_{OUT}=150mA$	--	800	950	mV
			$I_{OUT}=100mA$	--	520	680	mV
		$V_{OUT}=3.6V$	$I_{OUT}=150mA$	--	750	930	mV
			$I_{OUT}=100mA$	--	500	660	mV
		$V_{OUT}=5.0V$	$I_{OUT}=150mA$	--	670	900	mV
			$I_{OUT}=100mA$	--	420	600	mV
Line Regulation	ΔV_{LINE}	$V_{IN}=V_{OUT}+2V$ to 30V $I_{OUT}=10mA$	--	--	0.2	%/V	
Load Regulation	ΔV_{LOAD}	$V_{IN}=V_{OUT}+2V$, $1mA < I_{OUT} < 150mA$	--	25	60	mV	
Short Current Protection	I_{Short}	OUT Short to GND	--	80	--	mA	
Output Noise	e_N	10Hz to 100KHz $I_{OUT}=30mA$	--	120	--	μV_{RMS}	
Power Supply Rejection Ratio	PSRR	$V_{IN}=12V$, $I_{OUT}=1mA$	--	68	--	dB	

Typical Application Circuit

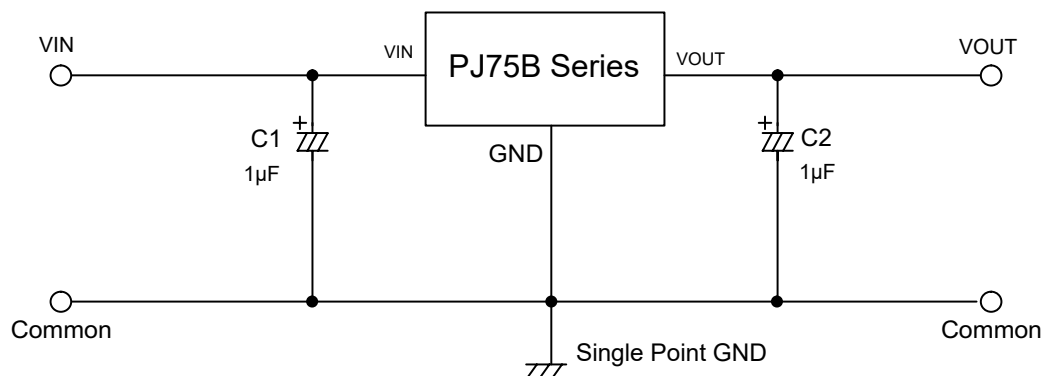



Typical Characteristics Curves

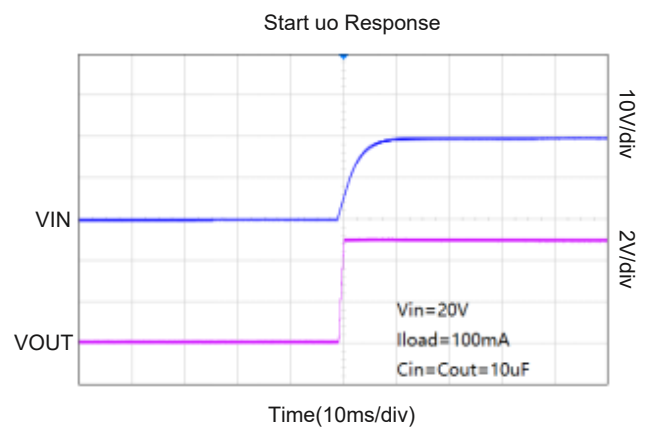
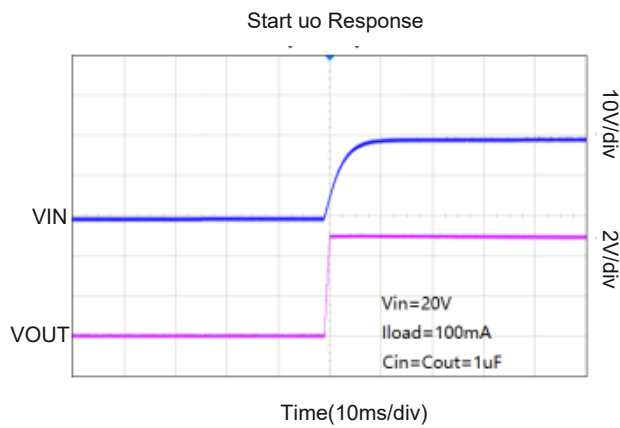
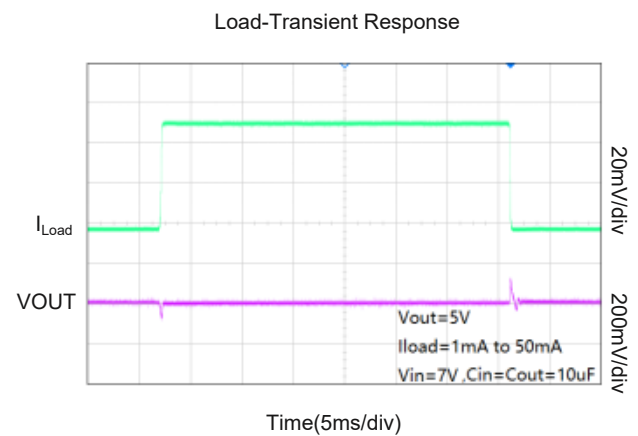
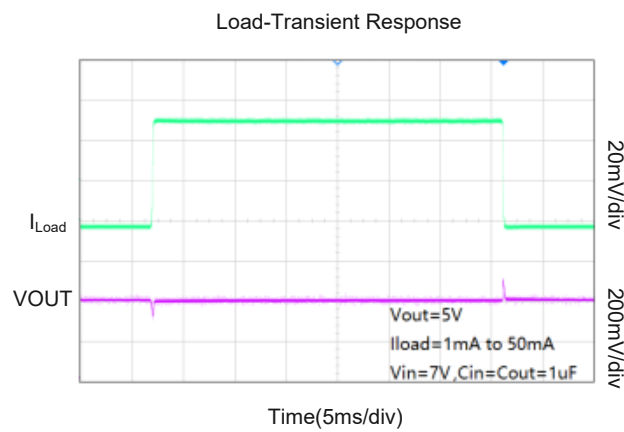
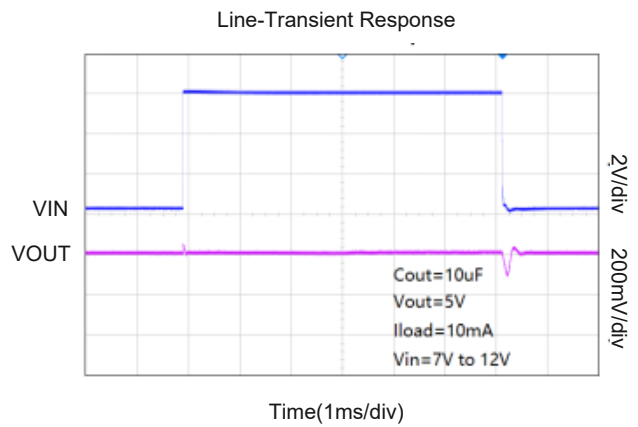
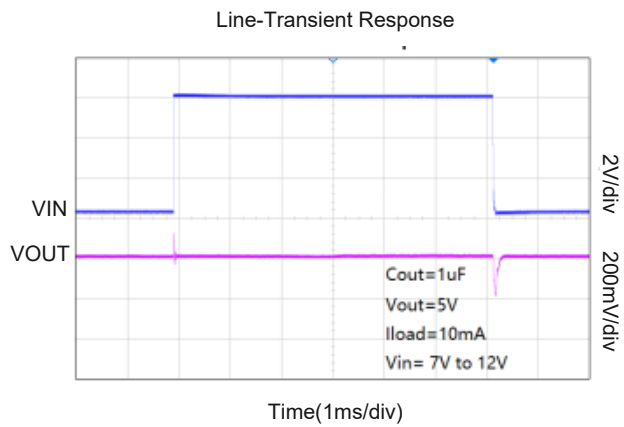



PJ75B Series Low Dropout Regulators

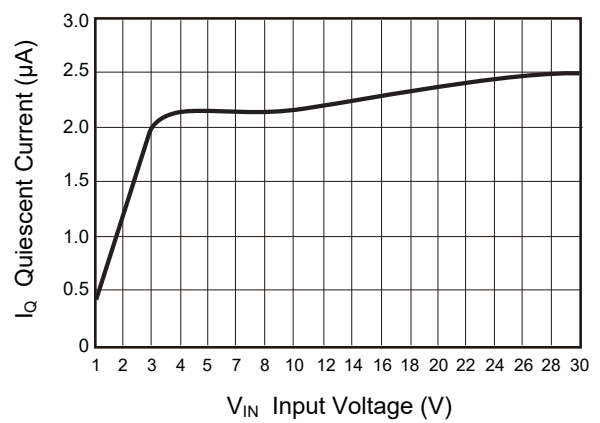
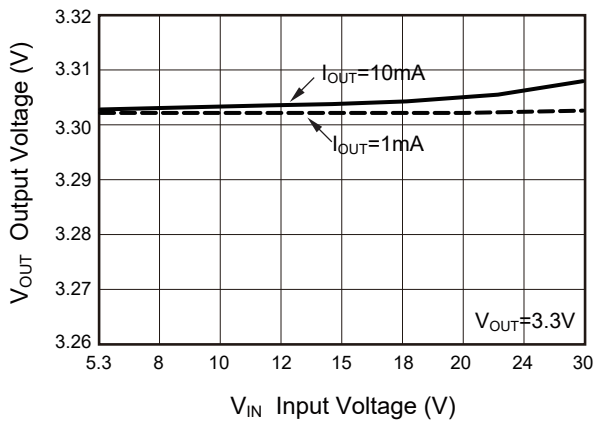
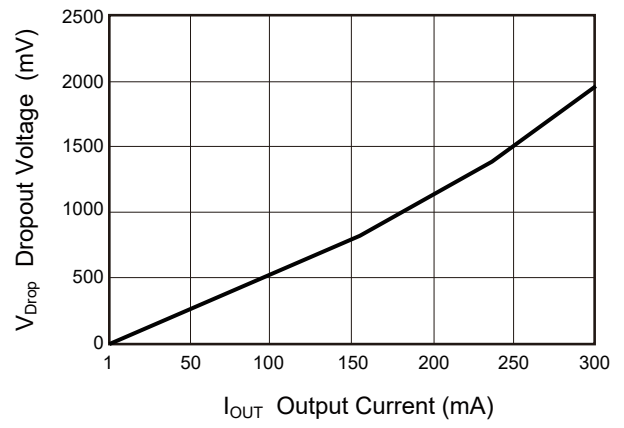
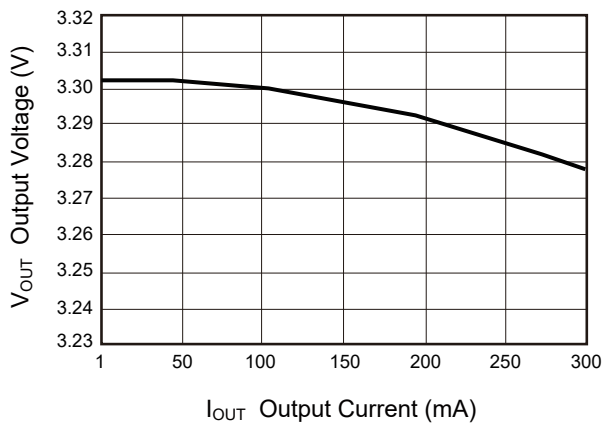
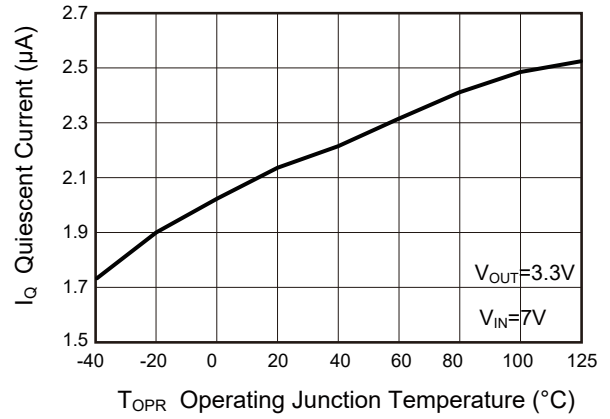
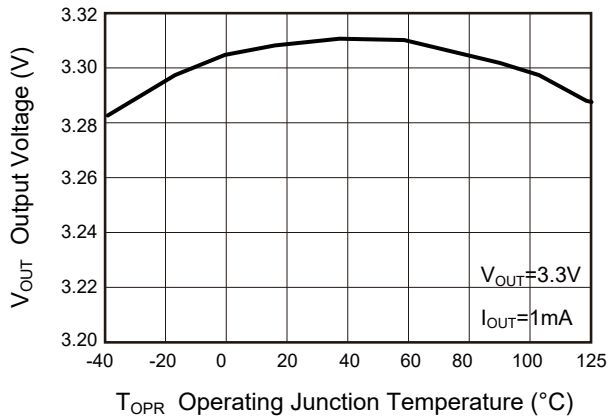



Applications Information

Input Capacitor

A 1 μ F~10 μ F ceramic capacitor is recommended to connect between VIN and GND pins to decouple input power supply glitch and noise. The amount of the capacitance may be increased without limit. This input capacitor must be located as close as possible to the device to assure input stability and less noise. For PCB layout, a wide copper trace is required for both VIN and GND.

Output Capacitor

An output capacitor is required for the stability of the LDO. The recommended output capacitance is from 1 μ F to 10 μ F, Equivalent Series Resistance (ESR) is from 5m Ω to 100m Ω , and temperature characteristics are X7R or X5R. Higher capacitance values help to improve load/line transient response. The output capacitance may be increased to keep low undershoot/overshoot. Place output capacitor as close as possible to OUT and GND pins.

Low Quiescent Current

The PJ75B Series consuming only around 2.5 μ A for all input range and output loading, provides great power saving in portable and low power applications.

Short Current Limit Protection

When output current at the OUT pin is higher than current limit threshold or the OUT pin is short-circuit to GND, the short current limit protection will be triggered and clamp the output current to approximately 100mA to prevent over-current and to protect the regulator from damage due to overheating.

Package Outline

SOT-23

Dimensions in mm

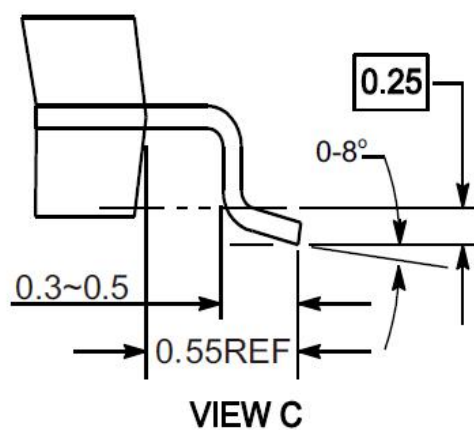
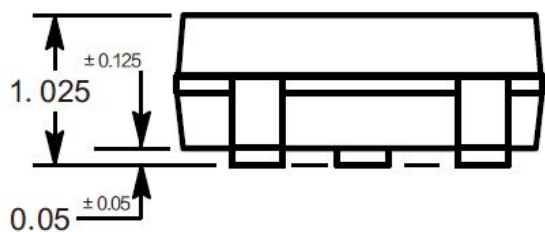
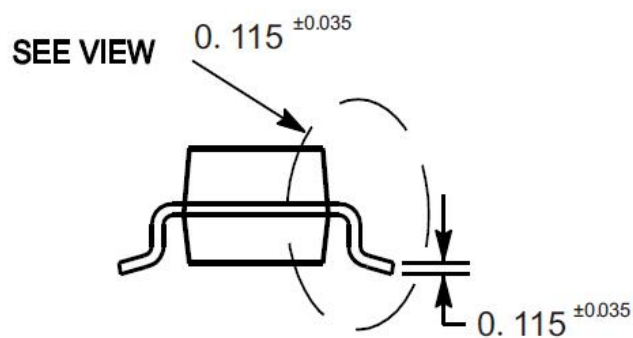
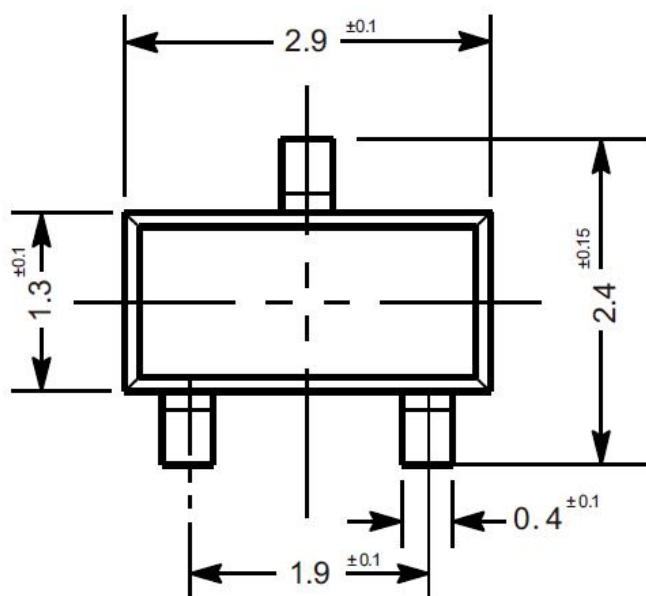

Ordering Information

Device	Package	Shipping
PJ75B Series	SOT-23	3,000PCS/Reel&7inches



PJ75B Series Low Dropout Regulators

Package Outline

SOT-23-3

Dimensions in mm

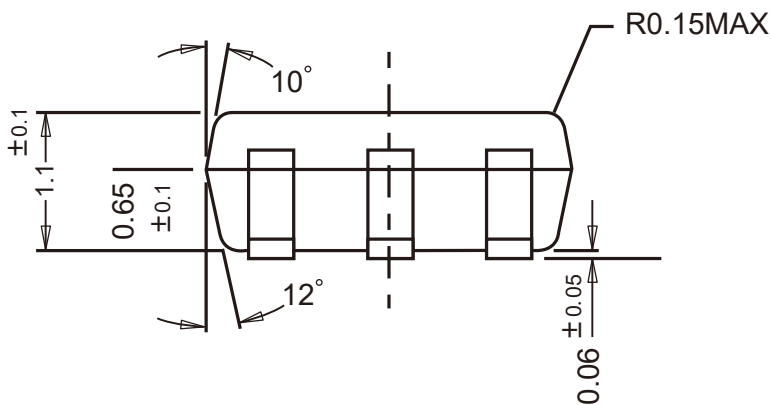
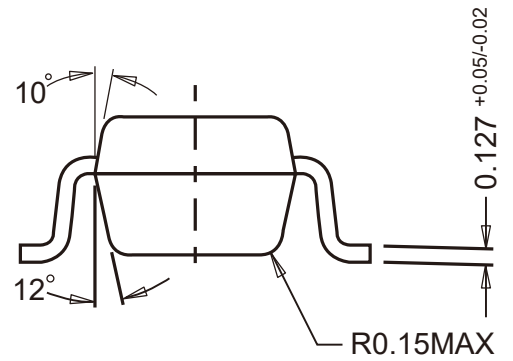
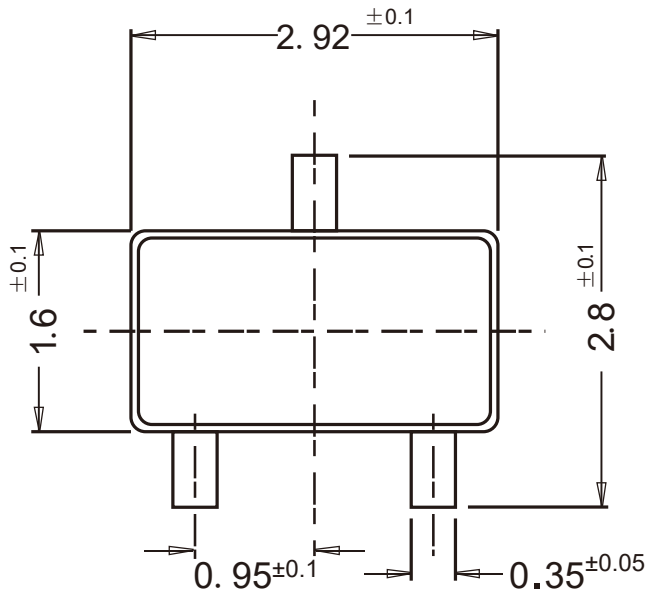

Ordering Information

Device	Package	Shipping
PJ75B Series	SOT-23-3	3,000PCS/Reel&7inches

Package Outline

SOT-89

Dimensions in mm

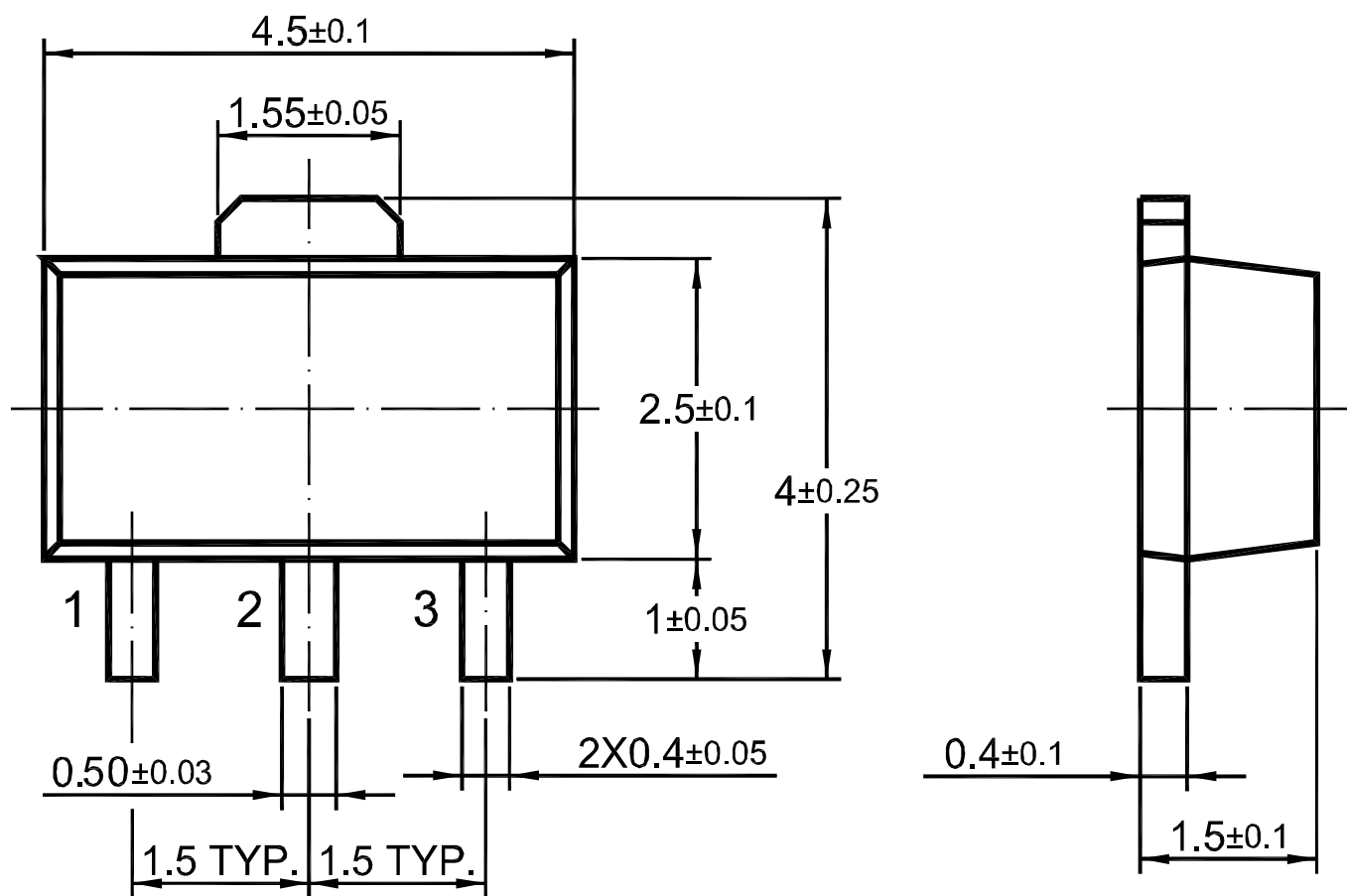

Ordering Information

Device	Package	Shipping
PJ75B Series	SOT-89	1,000PCS/Reel&7inches
		3,000PCS/Reel&13inches



PJ75B Series Low Dropout Regulators

Package Outline

SOT-23-5

Dimensions in mm

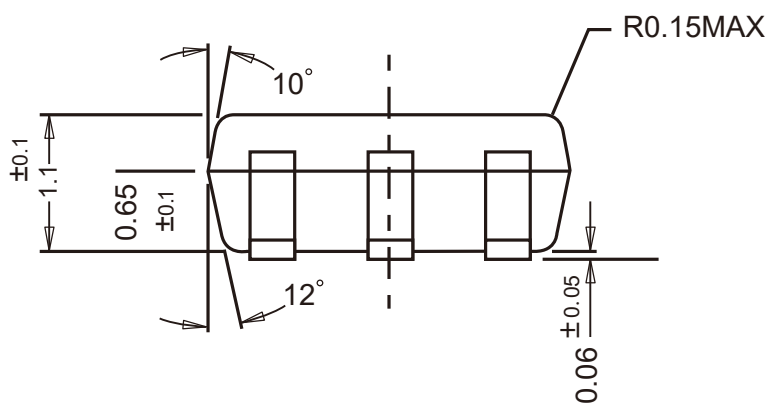
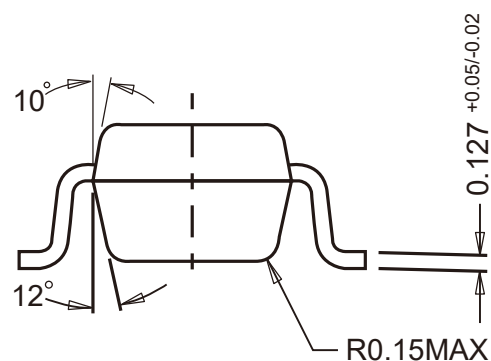
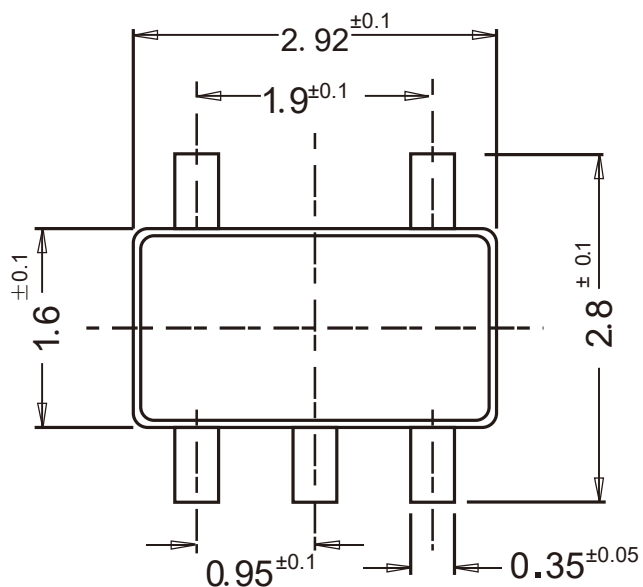

Ordering Information

Device	Package	Shipping
PJ75B Series	SOT-23-5	3,000PCS/Reel&7inches