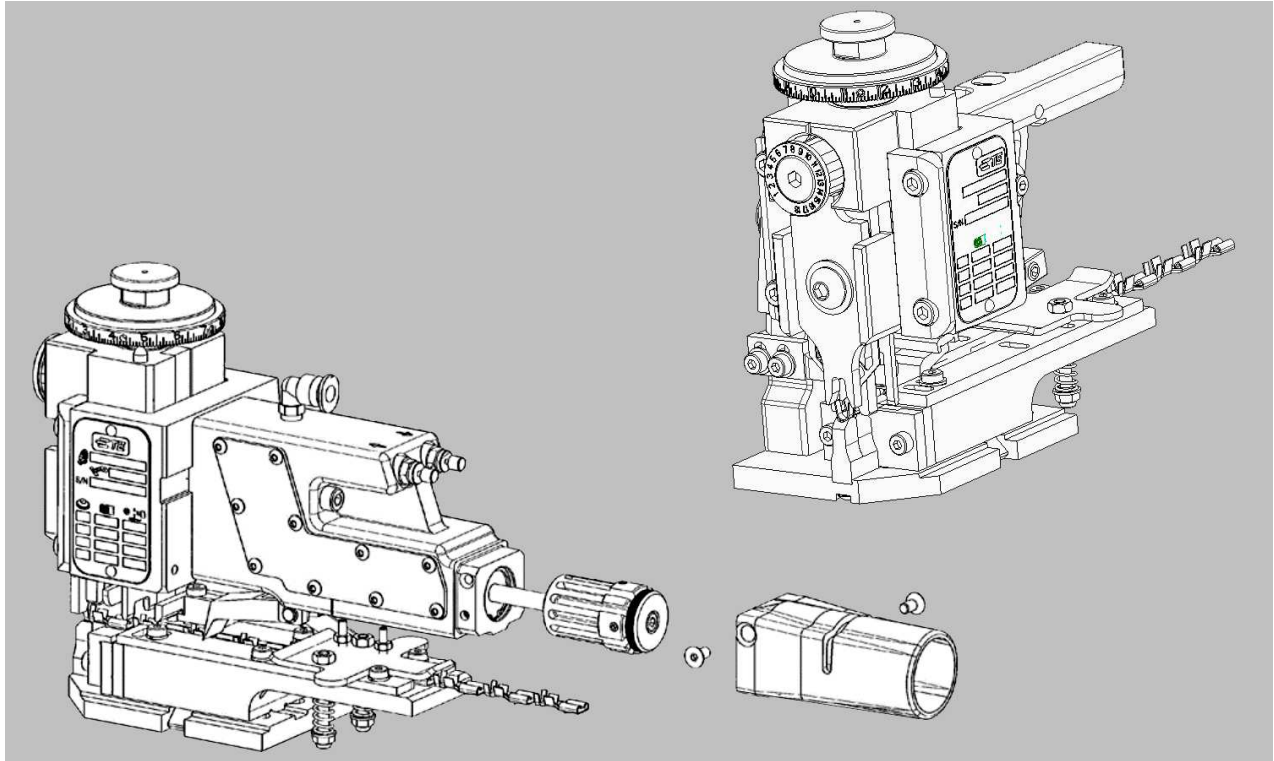

Figure 1: Ocean 1.0 end-feed applicators



1. INTRODUCTION

Ocean 1.0 end-feed applicators are available with a mechanical feed, air feed, or servo feed system. Each applicator accepts the end-feed strip-form of terminals identified on the applicator parts list and exploded view drawing (applicator log) to apply to pre-stripped wires.

i **NOTE**
 Dimensions in this instruction sheet are in millimeters with [inches in brackets]. Figures are for reference only and are not drawn to scale.

This instruction sheet, along with the parts list, exploded-view drawing (packaged with applicator), and applicable terminating machine manual (Table 1), provide all the information required to operate and maintain the applicator and machine.

Table 1: Terminating machine manuals

Manual	Machine
409-5128	Basic AMP-O-LECTRIC™
409-5207 409-5289	Model T
409-5842	Model G
409-10047	AMP 3K™ 1725950-[] AMP 5K™ 1725900-[]
409-10099	AMP 3K/40™ 2119683-[] AMP 5K/40™ 2119684-[]

i **NOTE**
 Refer to instruction sheet [408-35005](#) for translations of the Safety Warnings specified herein.

2. DESCRIPTION

Figure 2 shows the main components of the mechanical feed applicator. Figure 3 shows the main components of the air feed applicator.

Each applicator is individually designed for specific terminals. The wire crimp height and insulation crimp height can be adjusted to accommodate different wire sizes and insulation ranges. The applicator is also designed to accept modular-feed packages.

Figure 2: Mechanical feed applicator

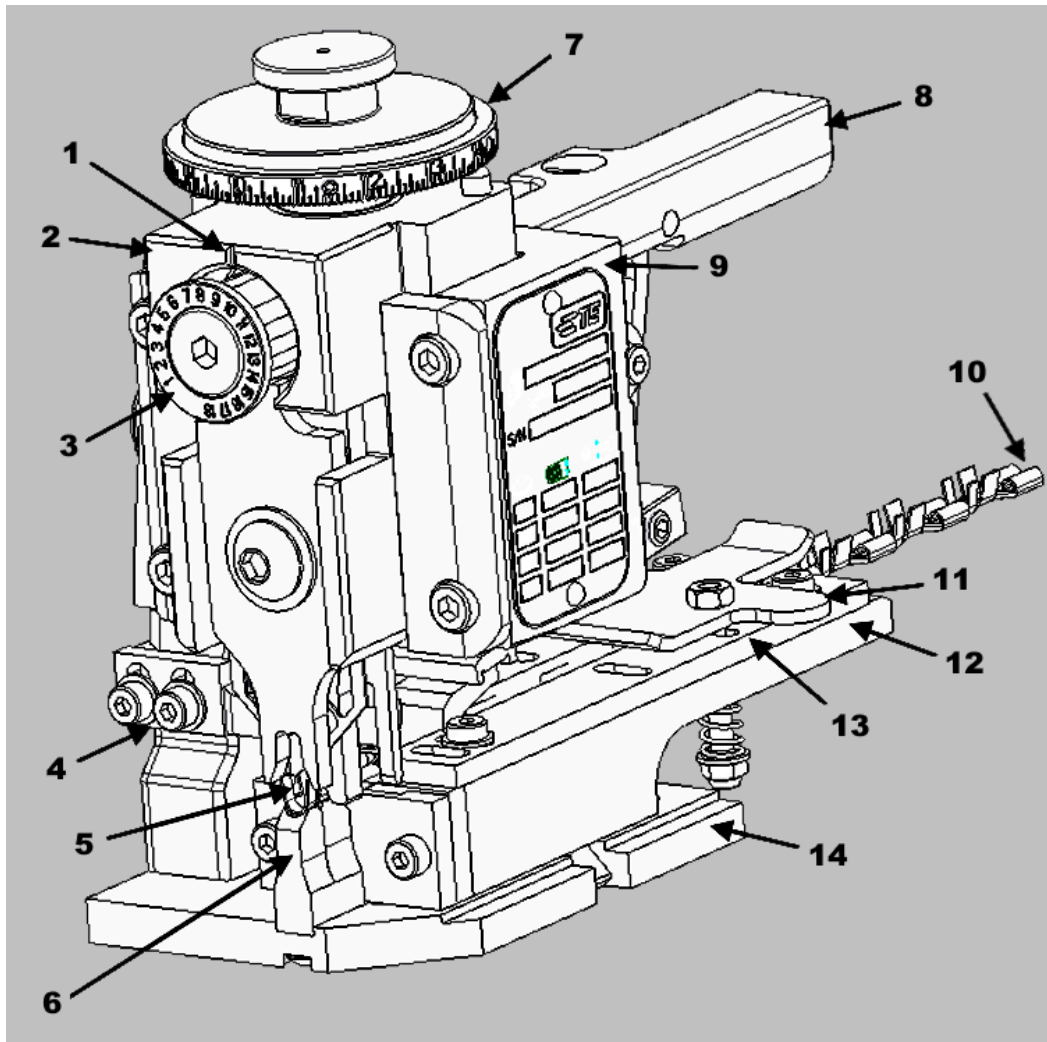

- | | | |
|--|--|------------------------------|
| 1 Indicator notch / cutout | 6 Anvil | 11 Drag release lever |
| 2 Ram assembly | 7 Wire crimp disc | 12 Strip guide block |
| 3 Insulation crimp dial | 8 Terminal feeder assembly | 13 Strip guide plates |
| 4 Stripper | 9 Applicator housing | 14 Base plate |
| 5 Lead terminal (for reference) | 10 End-feed strip-form terminal strip | |

Figure 3: Air-feed applicator

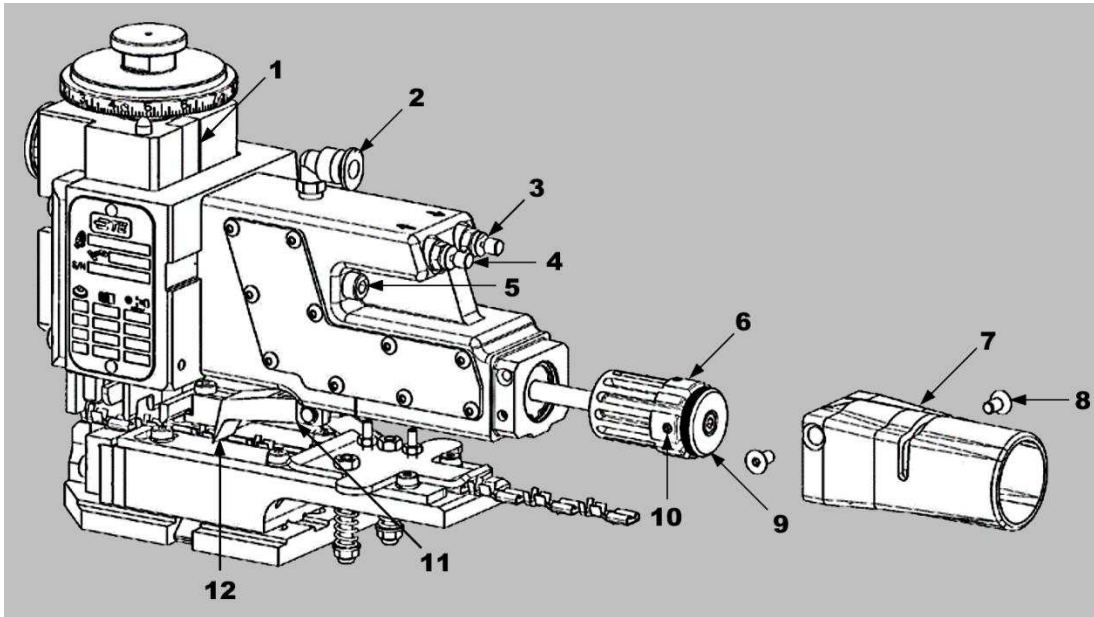

- | | | |
|--------------------------------|--------------------------------------|--|
| 1 Air feed cam | 5 Mounting screw (2 places) | 9 Feed backstroke adjustment knob |
| 2 Air supply connection | 6 Feed stroke adjustment knob | 10 Detent screw (2 places) |
| 3 Retract speed control | 7 End cap | 11 Feed arm |
| 4 Forward speed control | 8 End cap bolt (2 places) | 12 Feed pawl |

The feeder assembly can be removed from the applicator and replaced with any different style (mechanical, air, or servo feed) depending on requirements (Figure 4). To change to a different feed type, use the appropriate retrofit kit (Table 2).

Figure 4: Feeder assemblies

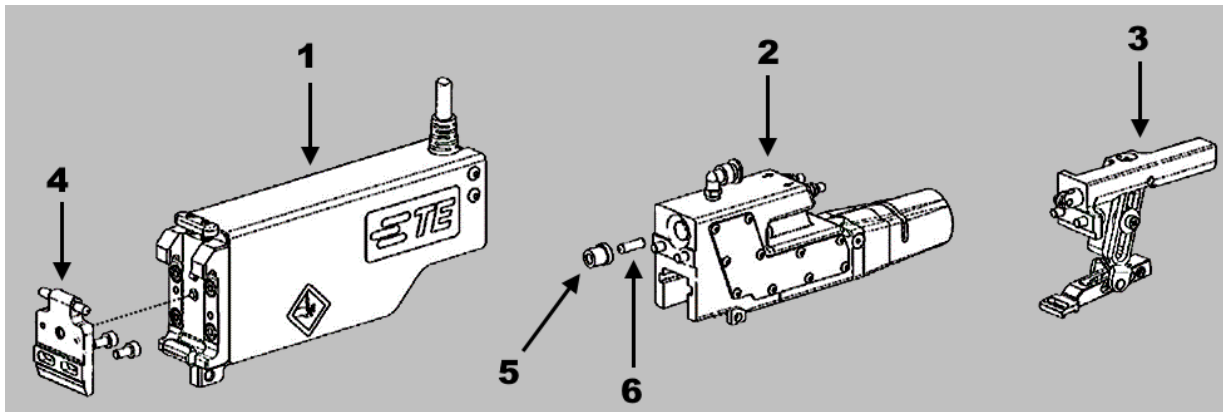

- | | |
|--|-----------------------------------|
| 1 Servo terminal feeder assembly | 4 Servo feeder latch plate |
| 2 Pneumatic terminal feeder assembly | 5 Bushing |
| 3 Mechanical terminal feeder assembly | 6 Push rod |

Table 2: Retrofit kits

Part number	Terminal feeder
2119949	Mechanical
2119950	Pneumatic
2119951	Servo

The Ocean applicator can be used in various machines, provided the machine has the proper stroke length and all the necessary equipment. Two basic applicator design styles (Atlantic and Pacific) are available to meet many of the terminator and leadmaker configurations worldwide (Figure 5). The applicator ram and base plate interfaces are different, but most of the Ocean applicator features and adjustments are the same.

Figure 5: Basic applicator design styles

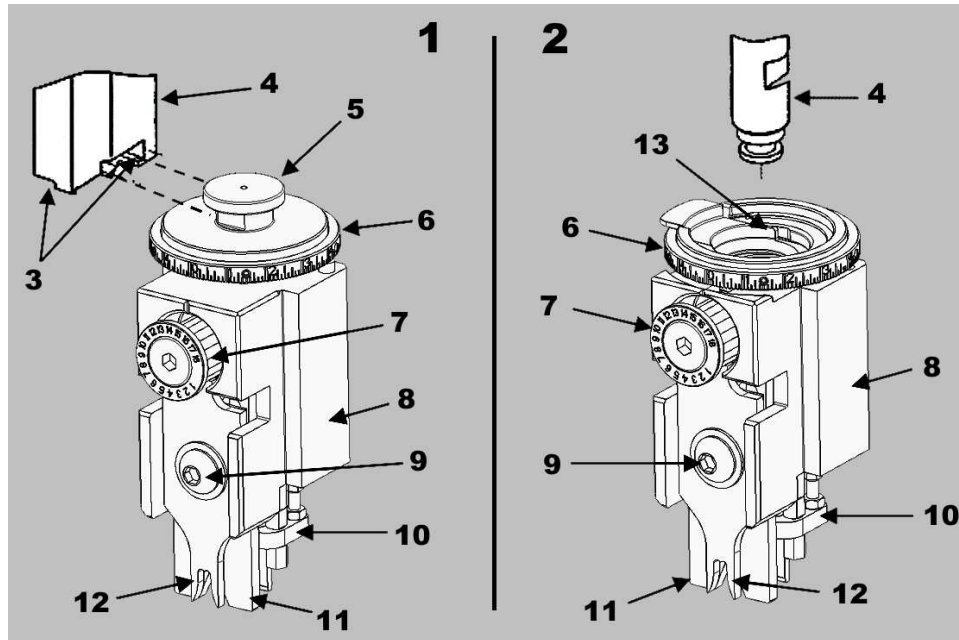

- | | | |
|---|--------------------------------|------------------------------|
| 1 Atlantic | 6 Wire crimp disc | 11 Wire crimper |
| 2 Pacific | 7 Insulation crimp dial | 12 Insulation crimper |
| 3 Boss | 8 Applicator ram | 13 Ram clamp |
| 4 Machine ram for ram post adapter | 9 Crimper bolt | |
| 5 Ram post | 10 Terminal hold-down | |

The terminal strip must be fed into the applicator, with the wire barrels facing up and first into the applicator, between the strip guide plates. It passes the stock drag, and the lead terminal is positioned over the anvil (for pre-feed applicators) or one terminal length from the anvil (for post-feed applicators). The feed pawl feeds one terminal during each cycle of the machine. The ram post (also referred to as the ram mounting post) engages the post adapter of the machine ram, which actuates the applicator.

The ram post interface is located just below the wire crimp disc, which is designed with a spring-loaded adjustment mechanism for precise crimp height adjustment increments of 0.01 mm [.0004 in.] and a total adjustment range of 1.50 mm [.059 in.]. By rotating the wire crimp disc, the ram interface raises and lowers relative to the applicator housing. The indicator notch of the ram points to the numbers on the perimeter of the wire crimp disc, indicating a relative crimp height. For proper crimp height, the number on the wire crimp disc must correspond to the number on the applicator identification tag and log sheet.

The wire crimper is held in a pre-set position by the ram and the crimper bolt. The insulation crimper and the front shear depressor are also held by the crimper bolt. The insulation crimper is free to move up and down so that the insulation crimp height can be adjusted via the insulation crimp dial by pulling the spring-loaded dial out slightly and rotating to a different number.

The slug blade, which cuts the connection tab from the strip between the lead and second terminals, is also attached to the bottom of the ram. The spring-loaded terminal hold-down, located on the ram, holds the terminal in place during the crimping and slugging process.

The applicator mounting surface is the base plate. The anvil, strip guide plate, and applicator housing are mounted on the base plate. The strip guides, stock drag, front and rear shear plates, and strip hold-down plate are all mounted on the strip guide plate. The shear plates are spaced to allow the slug blade to pass between them, removing the connecting tab between the terminals.

2.1. Applicator with mechanical feed system

With this applicator (Figure 6), the terminals are fed by the action of the feed cam and a series of rods and levers that move the feed pawl.

Figure 6: Applicator with mechanical feed system

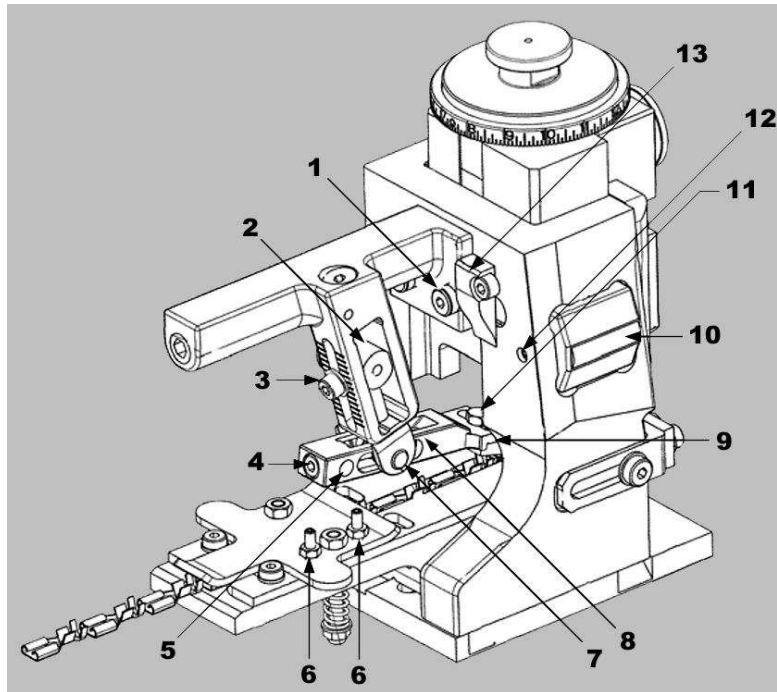

- | | | |
|---|-------------------------------------|---|
| 1 Feed mounting screw (2 places) | 6 Stock drag adjustment nuts | 11 Feed pawl adjustment screw |
| 2 Stroke pivot | 7 Feed pawl pin | 12 Applicator counter set screw |
| 3 Stroke length adjustment lock screw | 8 Feed pawl holder | 13 Spare feed cam storage location |
| 4 Fine feed adjustment screw | 9 Feed pawl | |
| 5 Fine feed adjustment lock screw (far side) | 10 Applicator counter | |

Two feed cams (Figure 7) can be used with the mechanical feed applicator.

- The *pre-feed* cam advances the lead terminal over the anvil on the upward stroke of the ram assembly so that a terminal is over the anvil when the machine is at rest. The pre-feed set up is typically used for side-feed bench applications.
- The *post-feed* cam advances the lead terminal over the anvil on the downward stroke of the ram assembly. The post-feed set up is typically used for leadmaker and end-feed bench applications.

Figure 7: Mechanical feed cams

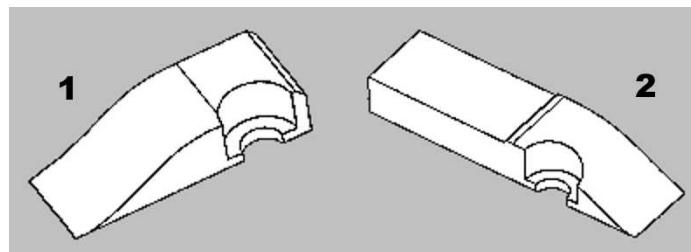

- 1** Pre-feed cam
- 2** Post-feed cam

These feed cams can be mounted in two different mounting holes, depending on machine stroke length and feed type (Figure 8 and Figure 9). When not in use, the spare feed cam can be mounted to the applicator housing in the spare feed cam storage location (Figure 6).

Figure 8: Mounting a feed cam on 40-mm [1½-in.] stroke machine

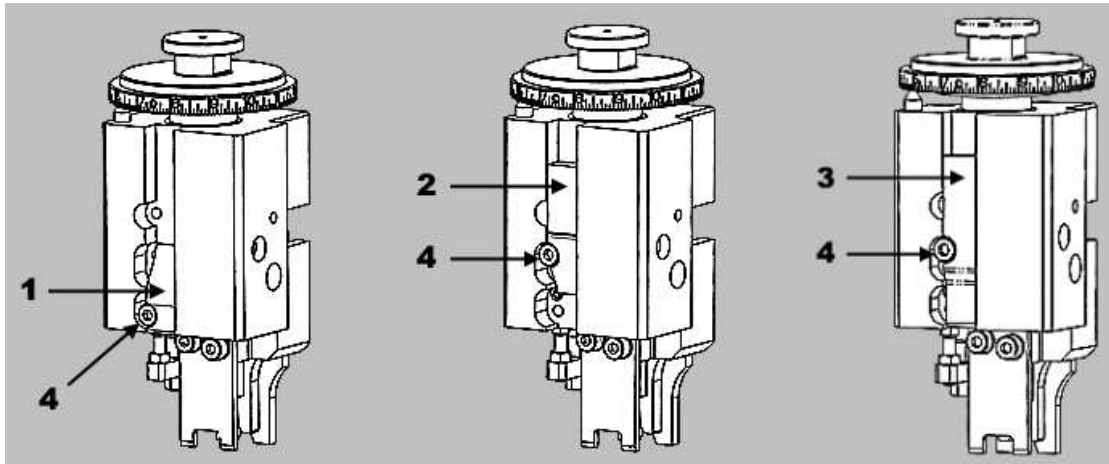

- 1 Mechanical pre-feed cam
- 2 Mechanical post-feed cam
- 3 Air-feed pre- or post-feed cam
- 4 Mounting screw

Figure 9: Mounting a feed cam on 30-mm [1¼-in.] stroke machine

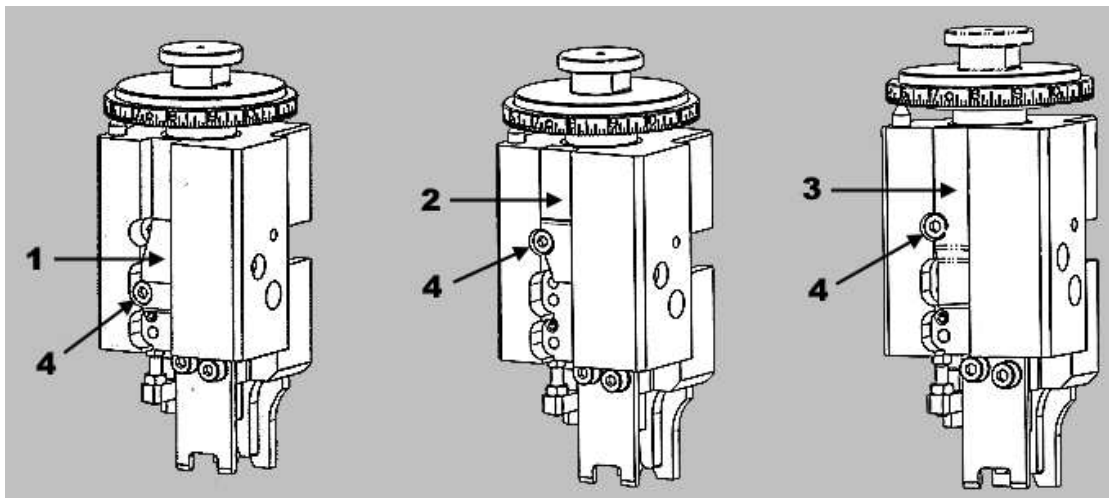

- 1 Mechanical pre-feed cam
- 2 Mechanical post-feed cam
- 3 Air-feed pre- or post-feed cam
- 4 Mounting screw

i **NOTE**
 Pacific applicators can only be used with 30-mm stroke machines. They have only the 30-mm feed cam mounting positions on the applicator ram.

i **NOTE**
 The recommended setup for mechanical end-feed applications is post-feed. The applicator can be configured for pre-feed, but this causes problems with some applications. Feed issues or terminal jamming can occur in the mechanical pre-feed configuration.

2.2. Applicator with air feed system

With an air feed applicator (Figure 3), the terminals are fed by the action of an air feed module using a constant air supply that moves the feed pawl. The exhaust control valves control the speed of the feed and retract strokes.

Two feed cams (Figure 10) can be used with the air feed applicator.

- The supplied *pre-feed* feed cam advances the lead terminal over the anvil on the upward stroke of the ram assembly, leaving a terminal over the anvil when the machine is at rest.
- An optional *post-feed* cam (part number 2391975-1) is available. It advances the lead terminal over the anvil on the downward stroke of the ram assembly, leaving the anvil clear when the machine is at rest.

Figure 10: Air feed cams

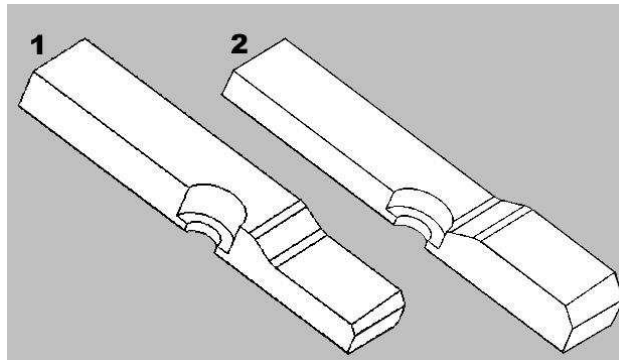

- 1** Pre-feed cam
- 2** Post-feed cam (optional)

These feed cams can be mounted in two different mounting holes, depending on machine stroke length and feed type (Figure 8 and Figure 9).

- The air supply connection (Figure 3) must be connected to an air supply line providing continuous pressure of 5.00 to 6.00 bars [72 to 87 psi] at the applicator.
- **No** oil lubrication of air is required for the Ocean air feed module after receiving and use within a production environment.
- The ram collar must be installed when changing crimp tooling to prevent the ram from becoming captured. If this occurs, the air feed assembly must be removed to release the applicator ram.



CAUTION

The air feed housing has a vertical etched line that serves as a visual aid to ensure that the piston assembly is located within the limits of the air cylinder position (see Figure 3). The feed pawl holder must be positioned to the right of the line. Incorrect positioning of the feed pawl can cause the air feed module to fail prematurely.

2.3. Applicator with servo feed system

With this applicator, the wire crimp height and terminal feed are accomplished by the AMP-O-LECTRIC III servo terminator or any machine that incorporates the TE Connectivity precision controller. Refer to [409-10073](#).

**NOTE**

Some applicators do not work with the standard feed pawl in the feeder. In these cases, a special feed pawl must be used. If originally ordered with the servo feed, the applicator is shipped with the special feed pawl already mounted.

Each servo feed applicator comes equipped with a data chip that is part of the servo feeder latch plate (see Figure 3). For a complete description of the data chip, refer to [409-10073](#). This device allows the storage of key operating parameters that allow easy setup between terminals. It also contains reference data that can be useful for other machine setups and crimp inspection.

[Batteries Directive 2006/66/EC](#) introduces new requirements from September 2008 concerning removability of batteries from waste equipment in EU Member States. To comply with this Directive, this device is designed to allow the data chip to be easily removed by the end-user when it must be replaced. Always dispose of the old data chip in an environmentally responsible way in accordance with local waste regulations. Contact local authority for battery recycling locations.

The servo feed applicator works in conjunction with the AMPOMATOR™ III servo terminator (or any machine that incorporates the TE precision controller) to form a complete system that allows setup and operation. The information on the data chip is listed in the three separate groups:

- Applicator data
- Terminal data
- Maintenance data

A significant amount of the data is reference data to aid in the setup of the machine and inspection of the final crimp.

2.4. Applicator with non-servo feed system

As with the data chip on the servo feed latch plate, optional data chip kit PN 2161326-[] also allows storage for key operating parameters and contains reference data that can be useful for other machine setup and crimp inspection. It requires compatible terminating equipment. For complete description of the data chip, refer to [409-10073](#).

2.5. Applicator with non-adjust head

With this applicator, all wire crimp height adjustments are made by the machine. At the factory, the applicator's non-adjust head is shimmed so that the applicator crimps its assigned terminal to the largest wire crimp height found on the applicator log while the terminating machine is set to normal shut height.

**NOTE**

If using an applicator with a fine-adjust head on a machine with a self-adjusting wire crimp height feature, always set the fine-adjust head to the largest wire crimp height called out on the applicator log.

2.6. Applicator with Pacific head

The Pacific applicator works only if the machine's ram falls within the envelope shown in Figure 11. (Dimensions are in millimeters, with inches in brackets.)

Figure 11: Ram dimensions for use with Pacific applicator

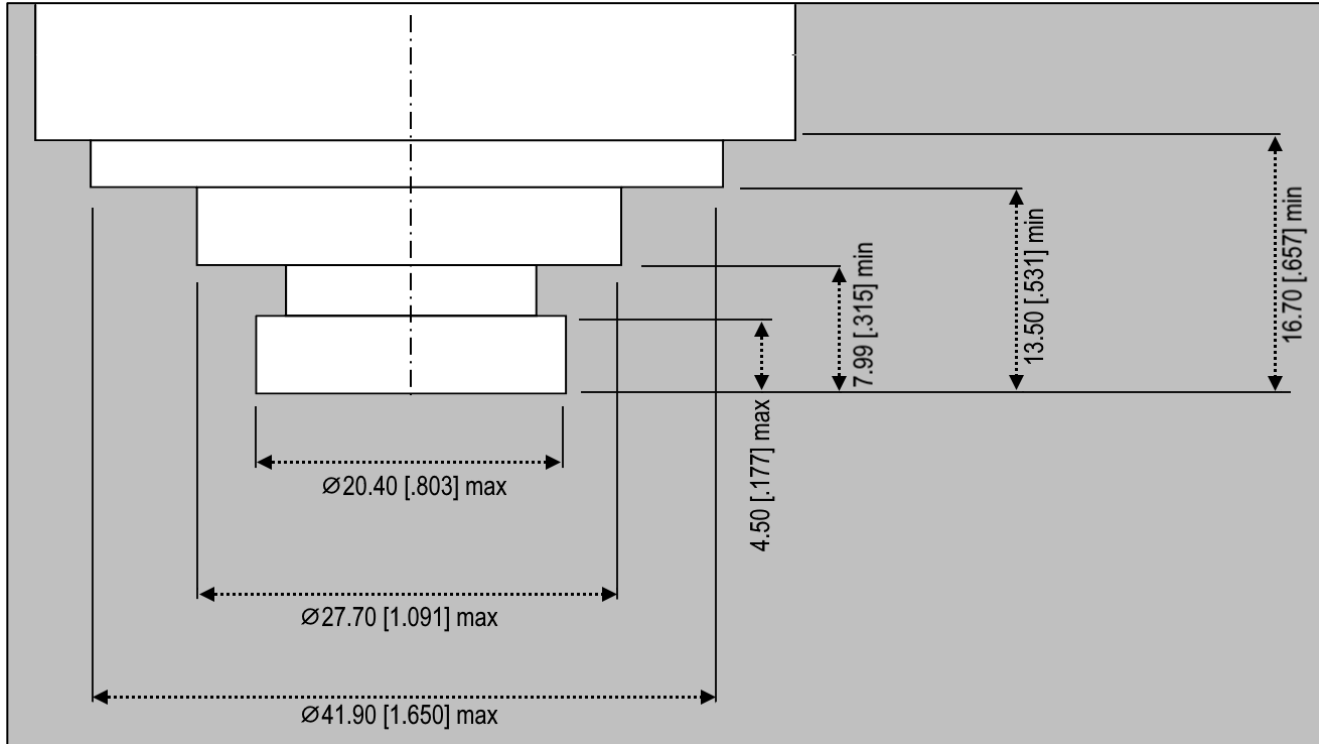

3. INSTALLING AND REMOVING THE APPLICATOR



Disconnect electrical power when performing maintenance or repair on this equipment.



Disconnect air supply when performing maintenance or repair on this equipment.



DANGER

To avoid personal injury, use the applicator **only** in an appropriate terminating machine. Do not connect the pressurized air supply until after the applicator is properly installed.



CAUTION

With the applicator in the machine, never attempt to cycle the machine under power without terminals properly loaded, as described in Section 4. Doing so can damage the tooling.



NOTE

Always remove the ram transportation collar after installing the applicator on a machine. Be sure to reinstall the ram transportation collar just before removing the applicator from the machine.

3.1. AMP-O-LECTRIC and Model K machines (with mini-applicator conversion)

A. Installation

This machine must be equipped with machine conversion kit PN 690675-2 to adapt it for use with miniature applicators. The kit includes applicator instruction sheet [408-8022](#), which explains how to install and remove an applicator with a mechanical feed.

B. Removal

1. Turn off the machine.
2. Disconnect the power cord.
3. Unload the applicator as described in section 4.
4. Remove the hold-down bracket and movable stop.
5. Slide the applicator away from the stop on the base mount until the ram post is clear of the machine ram.

3.2. Model T terminating unit (Atlantic only)

A. Installation

1. Turn off the machine.
2. Disconnect the power cord.
3. *Push in* the release bar on the quick-change base plate. The locking latch pivots *downward*.
4. Place the applicator on the quick-change base plate.
5. Slide it back until two notches engage the stops at the back of the plate, while guiding the ram post into the ram post adapter.
6. Flip the locking latch up to secure the applicator in place.

B. Removal

1. Turn off the machine.
2. Disconnect the power cord.
3. Cut the terminal strip one or two terminals from the end of the applicator.
4. *Push in* the release bar on the quick-change base plate. The locking latch pivots *downward*.
5. Slide the applicator forward until it is clear of the ram post adapter.

3.3. Other terminating machines

Refer to the appropriate machine manual (Table 1) for installation and removal procedures for the following machines:

- Basic AMP-O-LECTRIC
- Model G
- AMP 3K
- AMP 5K
- AMP 3K/40
- AMP 5K/40

For any other terminating machines, refer to the customer documentation supplied with the machine.



NOTE

When switching between the bench terminator and an automatic leadmaker, you might have to adjust the wire stripper up or down.

4. LOADING AND UNLOADING THE APPLICATOR

Some terminal strips require the use of a terminal lubricant to reduce tooling wear and help reduce damage to the plating on some terminals. Wick-type lubricators apply lubricant to the terminal strip as it feeds into the applicator. Ocean applicator lubricator assembly PN 2119955-2 is available.



Disconnect electrical power when performing maintenance or repair on this equipment.



NOTE

Depending on the final use of the crimped terminal, terminal lubricators are not always recommended. To determine whether your applications warrant the use of a terminal lubricator, contact your field representative.

If your application warrants the use of a terminal lubricator, use Stoner Terminal Lubricant E807 from Stoner, Inc. Call 800-227-5538 or visit Stoner's [Critical Cleaning](#) website.

4.1. Loading the terminal strip

1. Make sure that the installed applicator is the right one for the terminal to be applied. Compare the terminal part number on the reel with the numbers listed on the applicator parts list.
2. Turn off the machine.
3. Disconnect the power cord.
4. Make sure that the ram assembly is all the way up. If necessary, hand-cycle the machine to raise the ram. Refer to the machine customer manual.
5. Remove the applicator guard assembly.
6. Raise the stock drag by turning the drag release lever upward.
7. Remove a length of the terminal strip left in the applicator by grasping the terminals at the strip guide entry, raising the feed pawl, and pulling the strip straight out of the applicator.
8. With the reel of terminals installed on the reel support, feed the terminal strip into the applicator between the strip guides with the terminal wire barrel entering first and the open side of the wire barrel facing up.
9. Raise the feed pawl and continue to feed the terminal strip until the lead terminal is over the anvil and the feed pawl engages the terminal in the proper position.
10. If terminals are post-feed, lift the feed pawl and pull the strip back one terminal length. The lead terminal is moved over the anvil on the downward stroke of the ram assembly. Make sure that the tip of the feed pawl is in the feed hole of the carrier strip.



NOTE

Some carrier strips have additional holes that are not used for feed purposes.

11. Hand-cycle the machine several times to make sure the applicator is properly adjusted as described in section 5.
12. Reinstall the applicator guard assembly.

4.2. Unloading the terminal strip

Remove the strip section only as part of the loading procedure. It is not necessary to remove it for cleaning, lubrication, or repair.

1. Cut the terminal strip one or two terminals from the end of the applicator.
2. If terminals are post-feed, turn the drag release lever upward to raise the stock drag, lift the feed pawl, and move the lead terminal over the anvil.

5. ADJUSTMENTS

5.1. Adjusting the wire crimp

1. Select an increment number from 0 (largest crimp height) to 150 (smallest crimp height) from the data plate for the wire size to be used. Each increment represents a change in crimp height of 0.01 mm [.0004 in.].
2. Adjust the crimp height by turning the wire crimp height adjustment disc until the required increment number lines up with the indicator notch on the front of the ram (Figure 12).
 - Turn the disc clockwise to decrease the crimp height.
 - Turn the disc counter-clockwise to increase the crimp height.

Figure 12: Wire crimp height adjustment disc

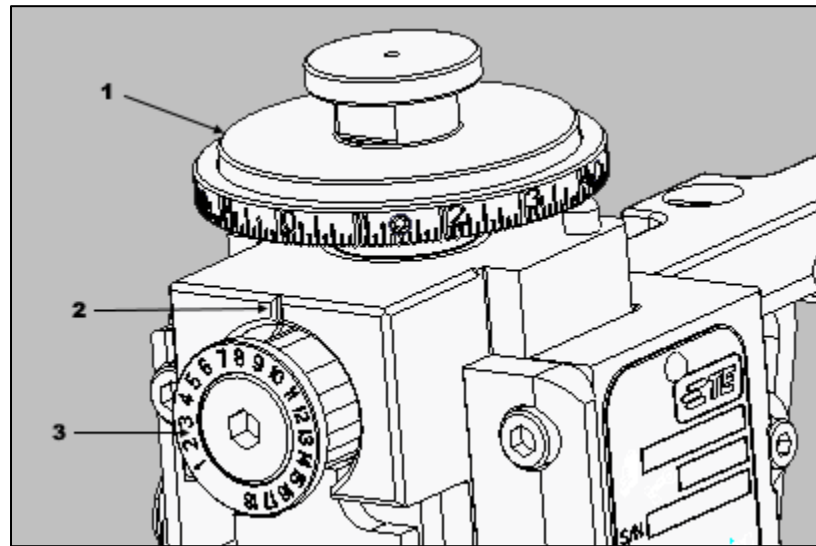

- 1** Wire crimp disc
- 2** Indicator notch
- 3** Insulation crimp dial

3. Adjust the insulation crimp as described in section 5.2.
4. Make several test cycles and inspect the terminations closely. Look for rough or sharp edges around the crimped barrels (flash), deformed crimps, bent terminals, or other defects caused by worn or broken tooling. If necessary, replace tooling as described in section 6.
 - If the terminations appear normal, measure the crimp height of each termination as described in instruction sheet [408-7424](#), packaged with the applicator. The crimp height must agree with the measurement specified on the applicator log for the wire size being used. Record crimp height dimensions for reference.
 - If the crimp height is incorrect, remove the applicator, and install one that is known to produce terminations of correct crimp height.
5. Make several test cycles and repeat the inspection.
 - If the crimp height is incorrect for this applicator, the problem is the machine shut height. Refer to the appropriate machine manual (Table 1) for corrective measures.
 - If the crimp height is correct, the problem is in the original applicator, and refer to section 6.8, **Repairing the adjustable crimp height**, for corrective measures.
6. During extensive operation, periodically inspect the terminals as described in step 3 to make sure that the applicator is producing correct terminations.

5.2. Adjusting the insulation crimp

The insulation crimp is adjustable in increments of 0.19 mm [.0075 in.] by pulling the insulation crimp dial out (refer to Figure 5) and turning it to line up with the number (1 through 18) so that it is shown at the indicator notch on the ram: Number 1 makes the loosest crimp and number 18 makes the tightest crimp. The total range of adjustment is approximately 3.30 mm [.130 in.]. Start with number 1 and make test crimps while increasing the setting one number at a time until the proper insulation crimp height is achieved.



NOTE

Some applicators have a special insulation adjustment dial with different range and increments. Refer to the marking on the front of the insulation crimp dial for correct increments.

5.3. Adjusting the terminal strip feed

A. Mechanical feed applicator



NOTE

When adjusting a mechanical feed applicator, always start by properly adjusting the stroke length. Then adjust the fine feed adjustment to position the terminal over the anvil.

1. With the terminal strip properly loaded, check the position of the lead terminal relative to the slug blade. Position the feed pawl in the required location on the terminal (typically the end of the wire barrel). Refer to Figure 6. The slug blade must remove the connecting tab between lead and second terminals without deforming either terminal.
2. Watch the feed pawl as the machine is hand-cycled (or slowly cycled) several times. It should have enough over-travel on the backstroke to pick up the next terminal, but not so much over-travel that the feed pawl moves up onto the body of the terminal (see Figure 13).
 - If the pick-up point is the mating end of the terminal, the backstroke over-travel should be about equal to the distance between the wire barrel and the mating end of the terminal (Figure 2).
 - For other types of terminals (for example, ring tongue), over-travel should be about the same, depending on the terminal features and configurations (for example, stud hole).

Figure 13: Feed pawl backstroke over-travel

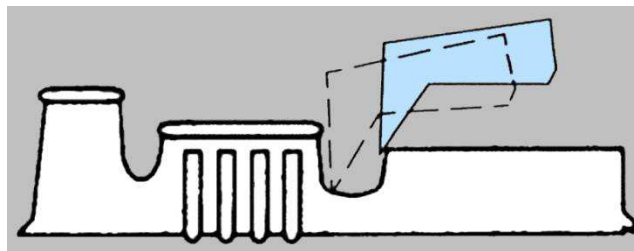

3. Check the backstroke position.
 - If the backstroke position is correct, the tab is correctly slugged out, and the terminals are not damaged, the feed adjustments are complete.
 - If not, continue to the next step.



NOTE

Two adjustments work in combination to properly position the lead terminal over the anvil and give the proper backstroke position to pick up the next terminal feed hole. Use **one** or **both** adjustment types to properly adjust the applicator.

4. If the slug blade does not shear the terminal in the correct position, make note of the position and continue to cycle the applicator to check the backstroke position. If the lead terminal is not slugged out correctly and the backstroke position is incorrect, both the stroke length and the fine feed position must be adjusted. Stroke length (backstroke position) must be adjusted before final centering of other terminals *under* the slug blade.
 - a. Loosen the stroke length adjustment lock screw (see Figure 6).
 - b. Turn the stroke length adjustment screw *counter-clockwise* to reduce the stroke length or *clockwise* to increase the stroke length.
 - c. Tighten the stroke length adjustment lock screw.
5. Repeat steps 1 through 4 as required until the proper stroke length is achieved.

If the feed pawl stroke length is satisfactory and the backstroke position is correct, but the lead terminal is not slugged out correctly (or positioned under the slug blade correctly) and the stroke is correct, but the position is incorrect, an adjustment to the fine feed screw is required. Continue to the next step.
6. Adjust the feed pawl position.
 - a. Loosen the fine feed adjust lock screw on the side of the feed pawl holder to allow the fine feed adjustment screw to turn. Refer to Figure 6.

**CAUTION**

Do not remove the fine feed adjust lock screw. A nylon plug is captured behind the lock screw. Loss of this plug causes damage to the fine feed adjustment screw threads when the lock screw is tightened.

- b. Turn the adjustment screw *counter-clockwise* to move the feed pawl away from the anvil and *clockwise* to move the feed pawl toward the anvil. Position the terminal *under* the slug blade.
 - c. Tighten the lock screw to secure the fine feed adjustment screw.
7. Re-check the adjustment for the proper position and stroke as described in step 1. Repeat the adjustment procedure as necessary.

B. Air feed applicator

The feed mechanism is actuated by compressed air. Refer to Figure 3.

**DANGER**

To avoid personal injury, use this applicator only in an appropriate terminating machine.

**DANGER**

*To avoid personal injury, do not connect the pressurized air supply until **after** the applicator is properly installed in the terminating machine. When the machine is manually cycled, the mechanism moves forward and backward once during each machine stroke, unless the air is disconnected.*

**DANGER**

Moving parts can crush and cut. Never insert hands into installed equipment.

**DANGER**

Do not wear jewelry, loose clothing, or long hair that can catch in moving parts of the equipment.

**DANGER**

Do not operate the equipment without guards in place.

B.1. Adjusting the feed stroke

The feed stroke is adjustable in a range of 0 to 49.8 mm, depending on the air feed part number, in stepped increments of 0.04 mm [.0016 in.] for the feed forward position and in 0.08-mm [.0031-in.] increments for the rear feed pawl position (backstroke).



NOTE

For ease of adjustment, remove the end cap with a 3-mm wrench, exposing the tool-less adjustment knobs. Air feed module PN 2063440 can be adjusted with the end cap in place using a 3-mm wrench or small screwdriver.

1. Mount the applicator on the machine.
2. Insert the terminal strip until the lead terminal is located over the anvil.
3. Connect the air supply to the applicator.
4. Cycle the machine manually.
5. The next terminal must now be located exactly over the anvil, and the slug blade *must* remove the connecting tab between the lead and second terminals without deforming either terminal. If that is not the case, do the following.
 - a. Release the strip guide drag, and manually move the strip to the proper position (a rough-position only).
 - b. Jog the machine down to the lower-dead-center position. The feed cylinder and pawl are retracted away from the anvil.
 - c. Using the backstroke adjustment knob (Figure 3), position the feed pawl to the proper back position, typically the end of the wire barrel (Figure 13). If the end cap is in place, use a 3-mm hex wrench or small screwdriver to reach through the end cap to rotate the feed adjustment knob. The adjustments are in 0.08-mm [.003-in.] increments or 30 degrees and can be felt as clicks.
 - If the pick-up point is the mating end of the terminal, the backstroke over-travel should be about equal to the distance between the wire barrel and the mating end of the terminal (Figure 3).
 - For other types of terminals (for example, ring tongue), over-travel should be about the same, depending on the terminal features and configurations (for example, stud hole).



NOTE

To facilitate adjustments with certain machines or applications, the feed adjustments can also be made with the air pressure removed. This allows more tactile feel of the detents. You must move the feed forward and back manually to check feed positions. The air feed housing marking (shown in Figure 3) indicates the maximum backstroke travel of the feed arm. Verify the feed forward and back positions after restoring air pressure.

- d. Jog the machine to top-dead-center. The feed moves the next terminal over the anvil.
- e. Check position of the terminal over the anvil, noting whether the terminal feed-forward position must be moved.
- f. Cycle the machine manually until the feed pawl shifts back. This releases the air pressure on the feed adjustment, making the adjustment detent positions easier to feel.
- g. Using the feed-forward adjustment knob, change the feed-forward position based on the direction and amount noted in substep d. The adjustments are in 0.04-mm [.0016-in.] increments or 15 degrees, and can be felt as clicks while rotating the knob.
 - Turning the knob clockwise moves the feed pawl away from the anvil.
 - Turning the knob counter-clockwise moves the feed pawl toward the anvil.



NOTE

Make sure that only the feed adjustment knob turns, not the entire shaft. You might have to hold the backstroke adjustment knob stationary to prevent unintended backstroke adjustments (use a 3-mm wrench when the end cap is in place).

- h. Cycle the machine back to top-dead-center, causing the feed to shift forward and feeding the terminal over the anvil.
- i. Repeat substeps d through h until the terminal is centered over the slug blade.

B.2. Adjusting the feed speed

The feed mechanism has been adjusted at the factory to ensure that the terminal is advanced at the lowest possible speed. It requires readjustment *only* in exceptional circumstances. On rare occasions, the feed speed is not fast enough if the applicator is used on a fully automatic machine. The feed speed can be adjusted by means of the two exhaust restrictors.



DANGER

To avoid personal injury, do not connect the pressurized air supply until **after** the applicator is properly installed in the terminating machine. When the machine is manually cycled, the mechanism moves forward and backward once during each machine stroke, unless the air is disconnected.



DANGER

Moving parts can crush and cut. Never insert hands into installed equipment.



DANGER

Do not wear jewelry, loose clothing, or long hair that can catch in moving parts of the equipment.



DANGER

Do not operate the equipment without guards in place.



CAUTION

The detent screws on feed adjustments (see Figure 3) are set up properly by the factory. Tampering with them causes damage.



CAUTION

Excessive feed or retract speeds can cause inconsistent feeds or air feed module damage.

To adjust the air feed speed, complete the following steps.

1. Open the exhaust restrictors or forward speed control and retract speed control (Figure 3) to increase the feed speed.
2. Loosen the locking ring.
3. Adjust the speed by turning the adjustment screw.
 - Turn the screw clockwise to decrease the speed.
 - Turn the screw counter-clockwise to increase the speed.
4. Tighten the locking ring.

C. Servo feed applicator

1. With the terminal strip properly loaded, check the position of the lead terminal over the anvil by actuating the feeder to move the feed pawl to the extend position. The slug blade must remove the connecting tab between the lead and second terminals without deforming either terminal.
 - If the lead terminal is centered on the anvil, the forward limit adjustment is correct. Skip to step 4.
 - If it is not centered, continue to step 2.
2. Adjust the extend position as described in the feeder instructions in customer manual [409-10073](#).
3. Repeat steps 1 and 2 as required. When the adjustment is correct, continue with step 4.
4. Watch the feed pawl as the machine is cycled several times.
 - It should have *enough, but not too much* over-travel on the retract (stroke) to pick up the next terminal.
 - At the end of the retract stroke, the feed pawl should be at the back edge of the feed hole to be used. The back stroke must not be longer than this; otherwise, the feed pawl might not drop into the feed hole.

5.4. Adjusting the stock drag

Adjust the stock drag to apply only enough pressure to the terminal strip so that it stops at the end of the feed finger stroke.

1. Turn the stock drag adjustment nuts (shown in Figure 6) to adjust the drag.
 - Turn the nuts down to increase the drag.
 - Turn the nuts up to decrease the drag.
2. Cycle the machine under power to verify that the stock drag is properly adjusted.

5.5. Adjusting the strip guide



Disconnect electrical power when performing maintenance or repair on this equipment.

1. Turn off the machine.
2. Disconnect the power cord.
3. Raise the ram.
4. Remove the applicator from the machine as described in section 3, INSTALLING AND REMOVING THE APPLICATOR.
5. Remove the ram assembly from the applicator.
6. Remove the two nuts holding the springs in place on the terminal drag plate (Figure 14).

Figure 14: Adjusting the strip guide

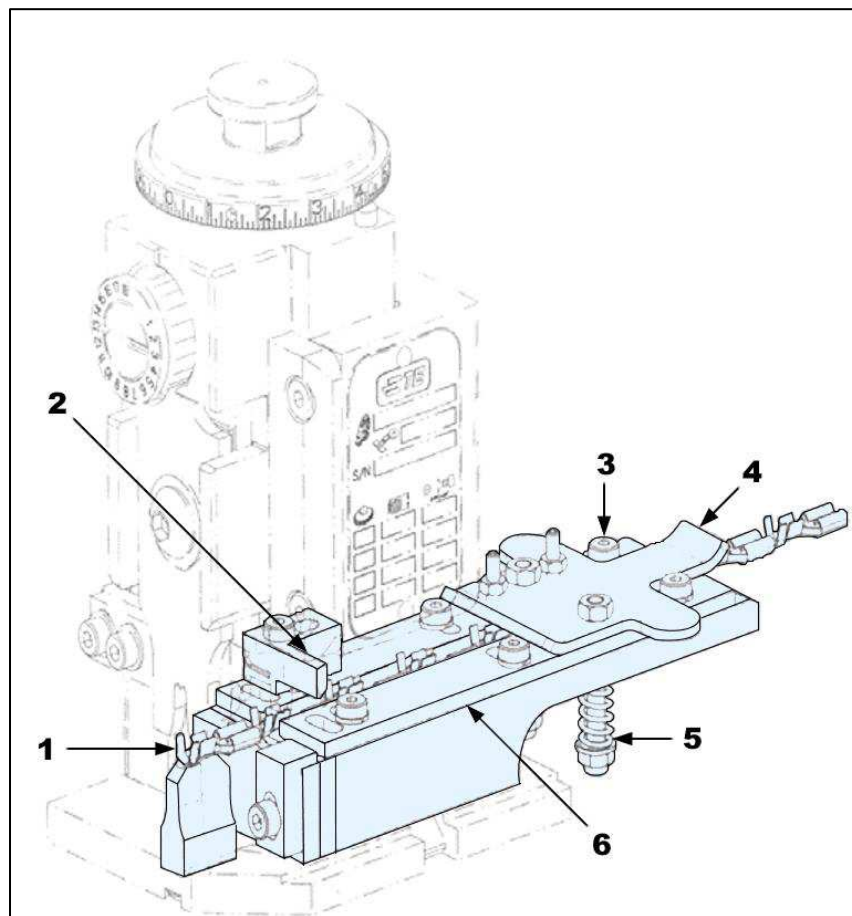

- | | |
|---|---|
| 1 Terminal strip aligned with anvil | 4 Terminal drag plate |
| 2 Strip hold-down plate (if present) | 5 Drag spring and retaining nut (2 places) |
| 3 Lower strip guide screw (6 places) | 6 Lower strip guide |

7. Remove the drag plate and springs.
8. Loosen (but do not remove) the six screws securing the lower strip guide.
9. With a terminal strip in place, adjust the guides to align and center the strip over the anvil.

10. Securely tighten the four rearmost screws. The strip should slide easily between the guides with a minimum of clearance.
11. If present, adjust the strip hold-down plate (Figure 14) so that it is square with the terminal strip. Position it so that it does not interfere with the slug blade tooling on the ram (Figure 5).
12. Tighten the remaining screws on the strip guide.
13. Verify the alignment of the terminal strip with the anvil. The strip must be centered over the anvil and in line with the radius nest on top of the anvil.
14. Reinstall the drag plate, drag springs, and securing nuts.
15. Adjust the drag.

6. REPLACEMENT AND REPAIR

These procedures cover the applicator parts that most often need replacement or repair due to wear. Stock and control a complete inventory to prevent lost time when replacement of parts is necessary.



Disconnect electrical power when performing maintenance or repair on this equipment.

6.1. Before replacing or repairing

1. Turn off the machine.
2. Disconnect the power cord.
3. Make sure that the machine ram is in the raised position
4. Remove the applicator from the machine.
5. For identification of parts, refer to the exploded view drawing on the applicator log and the parts list packaged with the applicator.
6. Wipe the parts with a clean, dry cloth as you remove them from the applicator.
7. Before putting parts back into the applicator, wipe the mating surfaces with your fingers to make sure that all lint and other foreign matter have been removed.

6.2. Replacing the anvil

1. From the bottom of the base plate, remove the screw that holds the anvil to the base plate.
2. Remove the anvil from the groove in the top of the base plate.
3. Install the anvil by reversing the order of steps 1 and 2. If a new anvil is needed, make sure the part number of the new anvil agrees with the number on the applicator parts list.

6.3. Replacing shear plates

1. Lift the stock drag and feed pawl.
2. Pull the section of the terminal strip back so that the lead terminal is between strip guides.
3. Remove the two screws that fasten the shear plates and spacers (if used) to the strip plates.
4. Record the position of the front and rear shear plates so that you can reinstall them correctly.
5. Remove the parts from the applicator.

6. Check the worn shear plates to determine whether they can be reoriented to provide another usable shearing edge.
 - Most rear plates are the same at the front and rear. If so, and if the second side is not worn, turn the plate front to the rear, making sure that the widest part of the chip clearance groove is at the bottom.
 - If the front plate is completely symmetrical, turn it so that any unused edge is at the top rear.
 - If the front plate does not require spacers and is the same on the top and bottom, turn it top to bottom (if the bottom edge is not already worn).
 - Make sure that the grooves face the rear shear plate.
7. With the old plates reoriented or the new plates properly positioned, install the shear plates and spacers (if used).
8. Fasten them in place with the two screws.
9. Hold the top of the ram assembly with one hand, while moving the feed pawl with the other hand. Slowly lower the ram assembly to check the alignment of the slug blade with the shear plates.
 - If side-to-side alignment is needed, loosen the two screws holding the shear plates, and move the plates to line them up properly. Re-tighten the screws.
 - If front-to-back alignment is needed, lay the applicator carefully on its side, and slightly loosen the four screws that hold the strip guide plate to the base plate. Move the strip guide plate in the required direction until the slug blade can pass freely between the shear plates. With the slug blade between the shear plates, retighten the four screws.
10. Set the applicator upright. Raise the ram assembly until the slug blade is clear of the shear plates.
11. Lower and raise the ram assembly several times to make sure that the slug blade moves in and out of the shear plates freely.
12. Lift the stock drag and feed pawl.
13. Slide the terminal strip section forward until the lead terminal is over the anvil.

6.4. Replacing the crimper

1. Loosen the crimper bolt slightly
2. Remove the ram assembly from applicator by pulling upward. It might be necessary to move the feed pawl forward to release the ram assembly.
3. Record the location of parts for reinstallation.
4. Remove the crimper bolt that holds the front shear depressor, front shear depressor spacer, tubular spacer, insulation crimper, crimper spacer, and wire crimper in place on the ram assembly.
5. Reinstall the parts by reversing the order of step 4. The upper end of the wire crimper must be up against the shoulder of the ram assembly.
6. Tighten the crimper bolt *only* finger-tight.



NOTE

*Crimpers **must** be positioned with the part number facing up. If new parts are used, make sure that the part numbers agree with the numbers on the applicator parts list.*

7. Put the ram assembly back into the applicator.
8. Install the applicator in machine.
9. Lift the feed pawl and pull the terminal strip back until the lead terminal is between the strip guides.
10. Form a piece of heavy paper over the anvil.

11. Slowly hand-cycle the machine while watching alignment of the crimpers with the anvil.
12. When the ram assembly reaches the bottom of the stroke, carefully tighten the crimper bolt to a torque between 10.8 and 13.6 Nm [8 and 10 ft-lb]. The crimpers must move without interference over the anvil after the heavy paper is removed.
13. Set the wire disc crimp height reference setting to zero.
14. Incrementally adjust toward the required crimp height. **Setting the crimp height reference setting too high can damage the crimp tooling.**

6.5. Replacing air feed bushings, piston rods, and O-rings

Air feed module rebuild kits PN 2217901-[] are available to replace worn air feed bushings, piston rods, and O-rings (call the number at the bottom of page 1 for kit info). For installation procedure, refer to [408-32121](#).

6.6. Aligning the applicator housing to the base plate

Each applicator is properly aligned at the factory, and the base plate bolts are sealed. However, it is possible to misalign the applicator housing from the base plate by mishandling or dropping the applicator. If the applicator becomes misaligned, contact a TE field service representative or order an end-feed applicator alignment gage (part number 2161422-3).

When aligning the applicator, make sure to torque the base plate screws (and, if needed, the gib screws) to the proper specification. Torque the base plate screws to 11.298 Nm [100 in.-lbs] and the gib screws to 5.649 Nm [50 in.-lbs].

6.7. Orienting the counter magnet

The applicator counter magnet (Figure 15) properly actuates the applicator counter only if it is installed with the correct side facing out from the ram. If the magnet is removed for any reason, you must determine which side of the magnet actuates the counter before reinstalling the magnet in the ram. You can do this by running the magnet behind the counter by hand to see which side of the magnet actuates the counter properly.

Figure 15: Application counter magnet

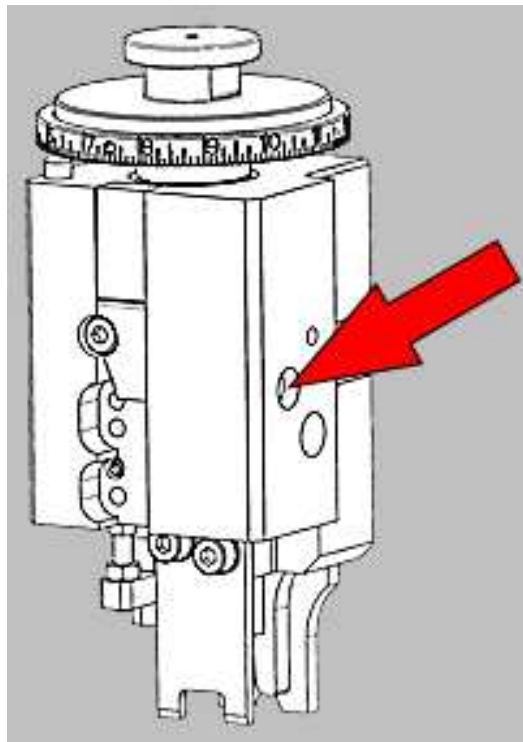

6.8. Repairing the adjustable crimp height

Under some severe operating conditions or applications, the crimp height shim can break or become dislodged. This can cause the applicator to produce terminations with a different crimp height than specified. To correct this problem, complete the following steps.

1. Subtract the specified nominal crimp height from the average crimp height recorded under section 5.1, **Adjusting the wire crimp**. This difference is the thickness of the shims (part number 2119957-1) to be *added* under the spacer.
2. Remove the ram assembly (Figure 16) from the applicator.

Figure 16: Replacing the crimp height shim

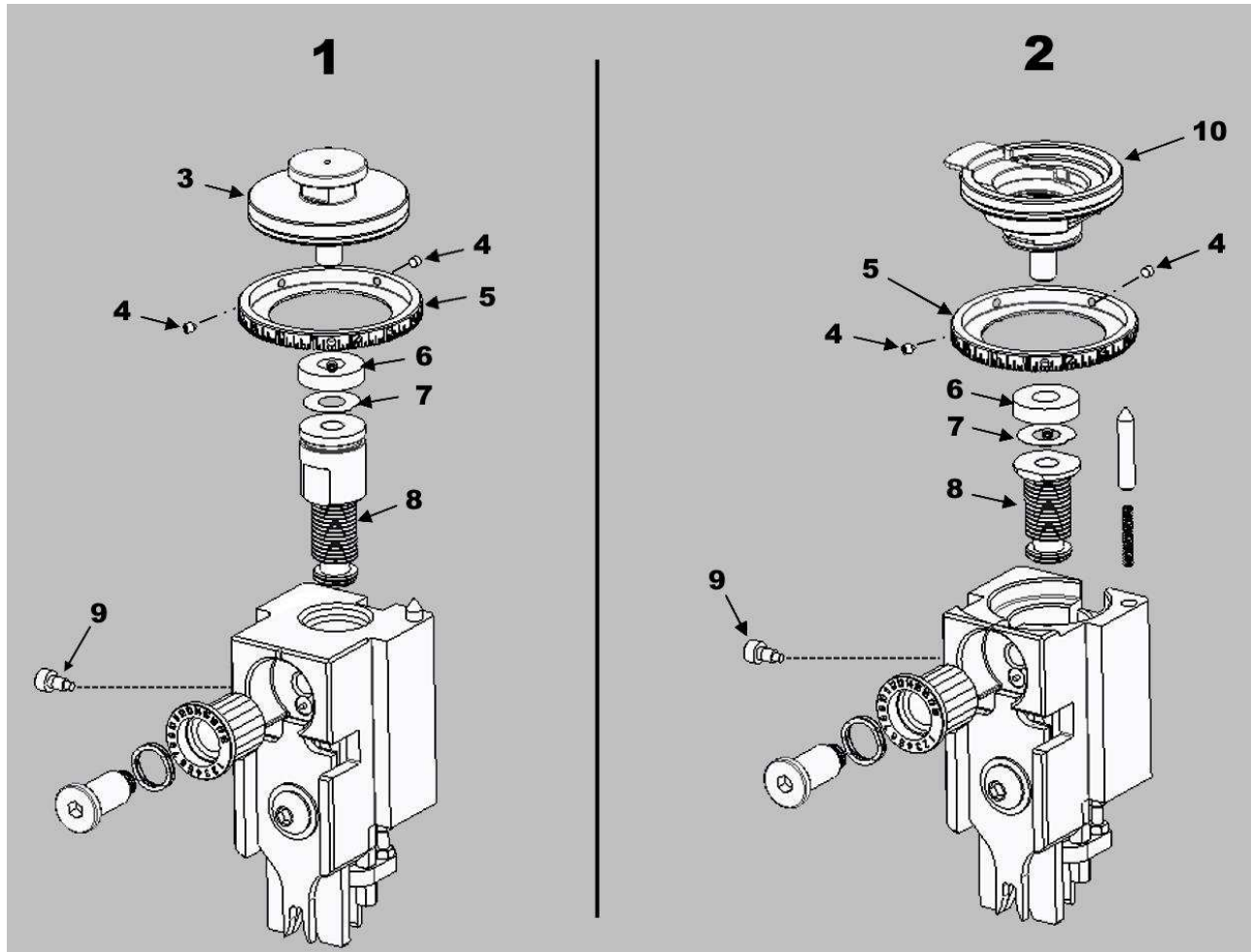

- | | |
|---|---|
| 1 Atlantic | 6 Spacer |
| 2 Pacific | 7 Shim |
| 3 Ram post | 8 Adjustment bolt |
| 4 Set screw* | 9 Single-revolution limiter bolt |
| 5 Numbered wire crimp height adjustment dial | 10 Ram clamp |

***Pacific only:** Install the set screws in holes that do not interfere with the ram clamp.

3. Remove the single revolution limiter bolt (Figure 16).
4. Hold the ram assembly with the ram post (or clamp, depending on the applicator style) pointing up.
5. Unscrew the ram post (or clamp) from the ram, exposing the adjustment screw assembly. If necessary, place the ram in a soft-jaw vise to free both hands for turning the ram post (or clamp).
6. Loosen and unscrew the ram post (or clamp) from the adjustment bolt to access the shims.
7. Select shims of the appropriate thickness.
 - a. Start with the amount to be added (determined in step 1).
 - b. If the old washer is broken and must be replaced, measure the thickness of the broken washer with a micrometer and add this measurement to the amount from step 1.
 - c. Select the new shims based the total.
8. Place the new shims on the ram post or clamp.
9. Re-tighten the ram post to the adjustment bolt with the spacer and new shims placed in between.
10. Lightly grease the threads of the adjustment bolt with the recommended greases.
11. While holding the ram with the hole facing up, assemble the adjustment screw assembly into the ram and tighten it by hand until it bottoms in the ram.

**NOTE**

Do not tighten the adjustment screw assembly. Just turn it in the assembly until it stops.

12. Reinstall the single revolution limiter bolt in the ram. Make sure that the numbered wire crimp height adjustment dial lines up properly, with the indicator wedge cut-out pointing to the zero on the numbered wire crimp disc.
13. If necessary, adjust the dial manually.
 - a. Loosen the three set screws holding the numbered wire crimp and height adjustment dial to the ram post.
 - b. Turn the dial until it indicates a zero reading.
 - c. Apply Loctite 222 threadlocker to the set screws.
 - d. Re-tighten the three set screws against the ram post. Turn each setscrew 60-90 degrees after contacting the center hub.

**CAUTION**

Do not tighten the set screws more than 90 degrees. Doing so can damage the numbered wire crimp height adjustment dial.

14. Put the ram assembly back into the applicator.
15. Install the applicator in the machine.
16. Make some test crimps. Measure the crimp heights and check them against the crimp height specified on the applicator parts list.
 - If the crimp heights are within specified tolerances, the applicator can be placed in service.
 - If not, repeat this procedure, starting with step 1.

6.9. Wire depressor accessory

If this accessory was not installed on the applicator at the factory, use Figure 17 to identify the parts you need in order to add it.



NOTE

To add a wire depressor to an existing applicator, the existing crimper spacer must be at least 0.64 mm [.025 in.] thick.

Figure 17: Wire depressor accessory parts

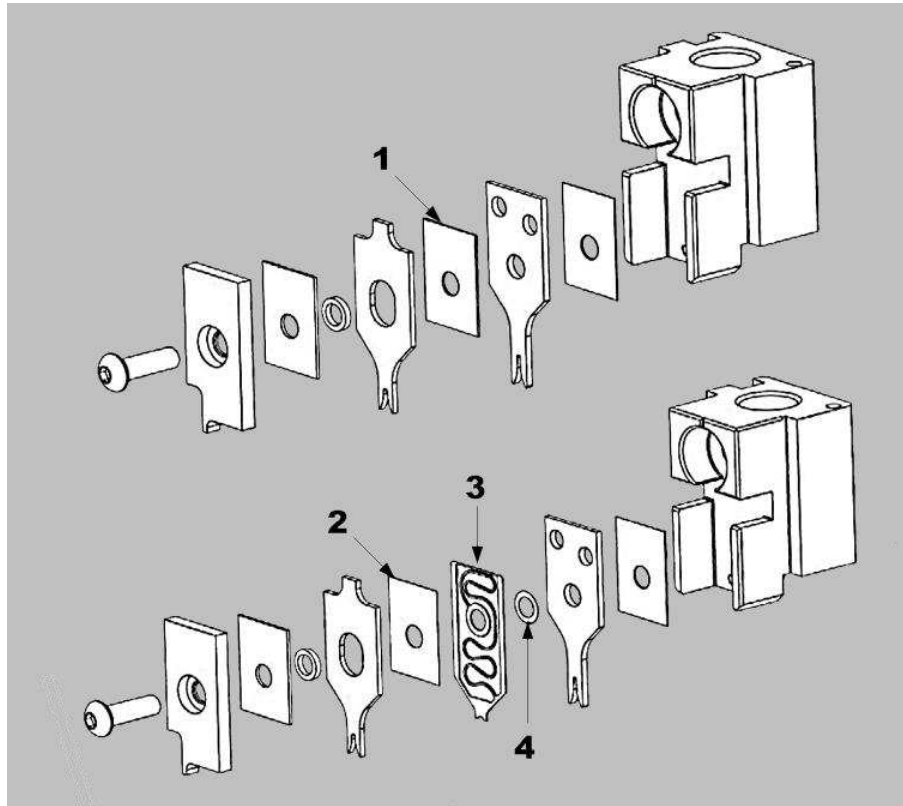

- 1 Existing crimper spacer
- 2 Replacement crimper spacer
- 3 Wire depressor (select based on wire size range)
- 4 Wire depressor washer spacer (part number 2119943-1) required

1. Use the following formula to calculate the thickness of the replacement crimper spacer:

$$S_e - 0.64 \text{ mm [.025 in.]} = S_r$$

where:

- S_e** = Existing crimper spacer thickness
- S_r** = Replacement crimper spacer thickness

- Use Table 3 **Error! Reference source not found.** to determine which crimper spacers you need to achieve the required thickness.

Table 3: Crimper spacers, by thickness

Thickness mm [in.]	Crimper spacer part number	Thickness mm [in.]	Crimper spacer part number	Thickness mm [in.]	Crimper spacer part number
0.25 [.010]	455888-1	1.52 [.060]	1-455888-2	2.67 [.105]	2-455888-3
0.30 [.012]	455888-2	1.57 [.062]	1-455888-3	2.67 [.105]	2-455888-3
0.38 [.015]	455888-3	1.65 [.065]	1-455888-4	2.79 [.110]	2-455888-4
0.51 [.020]	455888-4	1.78 [.070]	1-455888-5	2.92 [.115]	2-455888-5
0.66 [.026]	455888-5	1.91 [.075]	1-455888-6	3.18 [.125]	2-455888-7
0.79 [.031]	455888-6	2.03 [.080]	1-455888-7	4.37 [.172]	2-455888-8
0.89 [.035]	455888-7	2.16 [.085]	1-455888-8	5.08 [.200]	2-455888-9
1.02 [.040]	455888-8	2.29 [.090]	1-455888-9	3.63 [.143]	3-455888-2
1.14 [.045]	455888-9	2.36 [.093]	2-455888-0	3.56 [.140]	3-455888-7
1.27 [.050]	1-455888-0	2.41 [.095]	2-455888-1	4.83 [.190]	7-455888-2
1.40 [.055]	1-455888-1	2.54 [.100]	2-455888-2		

- Choose a wire depressor based on the wire size range (Table 4).

Table 4: Wire depressors, by wire size range

Wire size range	Wire depressor part number
0.008-1.305 mm ² [38-16 AWG]	2119791-5
0.150-5.270 mm ² [20-10 AWG]	2119791-9

- Order the replacement components you need.
 - Crimper spacers (chosen in step 1)
 - Wire depressor (chosen in step 3)
 - Washer spacer (part number 2119943-1)



NOTE

When fitting crimper spacer PN 455888-5 or 455888-6 to the applicator, use **only** the wire depressor and corresponding spacer.

7. CLEANING, LUBRICATION, AND STORAGE

For best performance and minimum downtime, the applicator should be cleaned (daily and monthly), inspected, lubricated, and stored as indicated in instruction sheet [408-8059](#).

8. REVISION SUMMARY

Revisions to this instruction sheet include:

- Reformatted to current standard for instruction sheets.
- Edited for organization and clarity.
- Updated information about feed cams in sections 2.1 and 2.2.
- Updated information about the air feed applicator in section 2.2.