

Nov.1.2022 Copyright 2022 HIROSE ELECTRIC CO., LTD. All Rights Reserved.
In case of consideration for using Automotive equipment / device which demand high reliability, kindly contact our sales window correspondents.

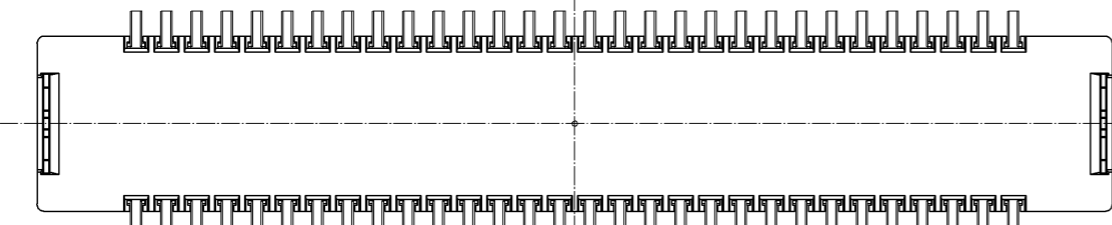
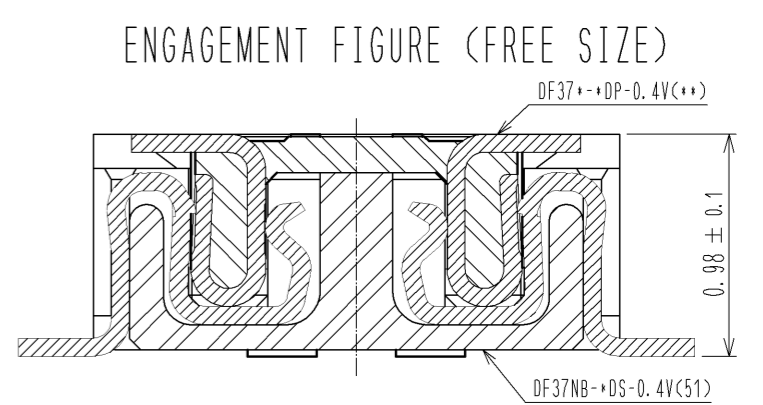
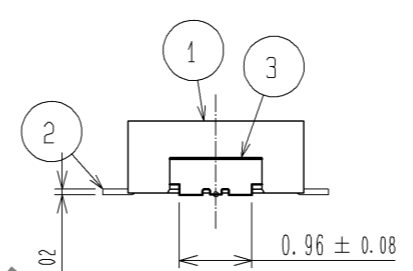
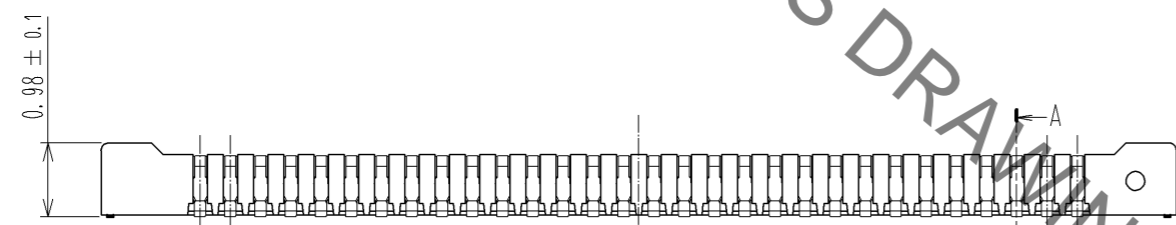
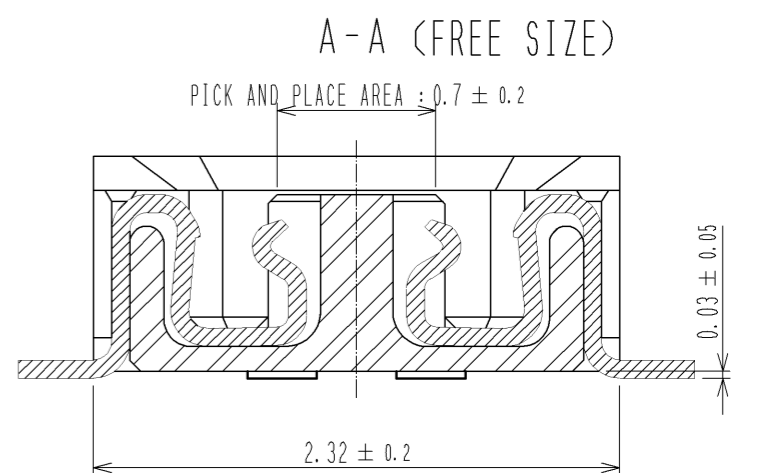
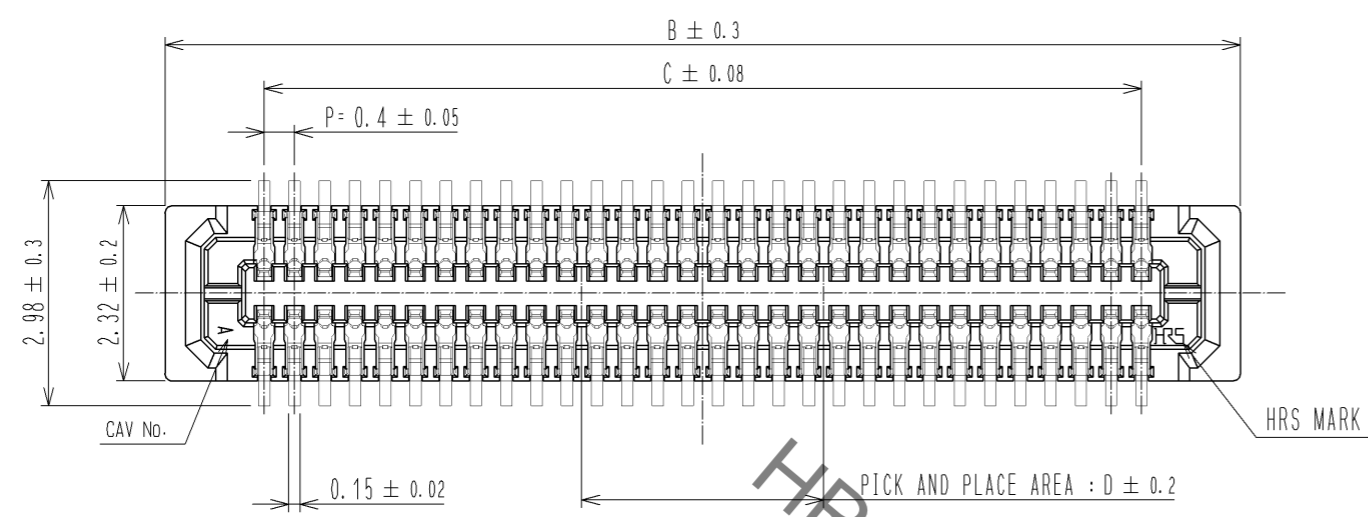

NOTE 1. ALL LEADS CO-PLANARITY SHALL BE 0.1mm MAX.

② CONTACT PLATING SPECIFICATIONS.
CONTACT AREA : GOLD 0.05 μm MIN.
SMT LEAD : GOLD 0.05 μm MIN.
UNDERPLATING : NICKEL 1 μm MIN.
(SURFACE : SEALING)

③ METAL HOLD DOWN PLATING SPECIFICATIONS.
MOUNTING AREA: GOLD 0.05 μm MIN.
UNDERPLATING : NICKEL 1 μm MIN.

HRS DRAWING FOR REFERENCE

PART No.	CL No.	B	C	D
DF37NB-10DS-0.4V(51)	CL684-3301-6-51	4.22	1.6	0.8
DF37NB-16DS-0.4V(51)	CL684-3302-9-51	5.42	2.8	1.2
DF37NB-20DS-0.4V(51)	CL684-3303-1-51	6.22	3.6	1.6
DF37NB-24DS-0.4V(51)	CL684-3304-4-51	7.02	4.4	2.0
DF37NB-30DS-0.4V(51)	CL684-3305-7-51	8.22	5.6	2.0
DF37NB-34DS-0.4V(51)	CL684-3082-4-51	9.02	6.4	2.4
DF37NB-40DS-0.4V(51)	CL684-3306-0-51	10.22	7.6	2.4
DF37NB-44DS-0.4V(51)	CL684-3407-7-51	11.02	8.4	2.8
DF37NB-50DS-0.4V(51)	CL684-3307-2-51	12.22	9.6	2.8
DF37NB-60DS-0.4V(51)	CL684-3308-5-51	14.22	11.6	3.2
DF37NB-70DS-0.4V(51)	CL684-3409-2-51	16.22	13.6	3.6
DF37NB-74DS-0.4V(51)	CL684-3080-9-51	17.02	14.4	4.0

3	PHOSPHOR BRONZE	③	6	PS	PLASTIC REEL (BLACK)					
2	PHOSPHOR BRONZE	②	5	POLYESTER	CLEAR (COVER TAPE)					
1	LCP	UL94V-0, BLACK	4	PS	CLEAR (EMBOSSED CARRIER TAPE)					
NO.	MATERIAL	FINISH, REMARKS	NO.	MATERIAL	FINISH, REMARKS					
UNITS	mm	SCALE	FREE	COUNT	3	DESCRIPTION OF REVISIONS	DESIGNED	CHECKED	DATE	
				DIS-H-005494		KR. AJITO		TS. MIYAZAKI		11.02.04
HIROSE ELECTRIC CO., LTD.		APPROVED : KH. IKEDA		09.10.23		DRAWING NO.		EDC3-319685-02		
		CHECKED : TS. MIYAZAKI		09.10.23		PART NO.		DF37NB-*DS-0.4V(51)		
		DESIGNED : RT. SHIMIZU		09.10.23		CODE NO.				
		DRAWN : YN. SAKAMOTO		09.10.20						

Nov.1.2022 Copyright 2022 HIROSE ELECTRIC CO., LTD. All Rights Reserved.
In case of consideration for using Automotive equipment / device which demand high reliability, kindly contact our sales window correspondents.

◆ RECOMMENDED PCB LAYOUT(MOUNTING SURFACE SIDE)

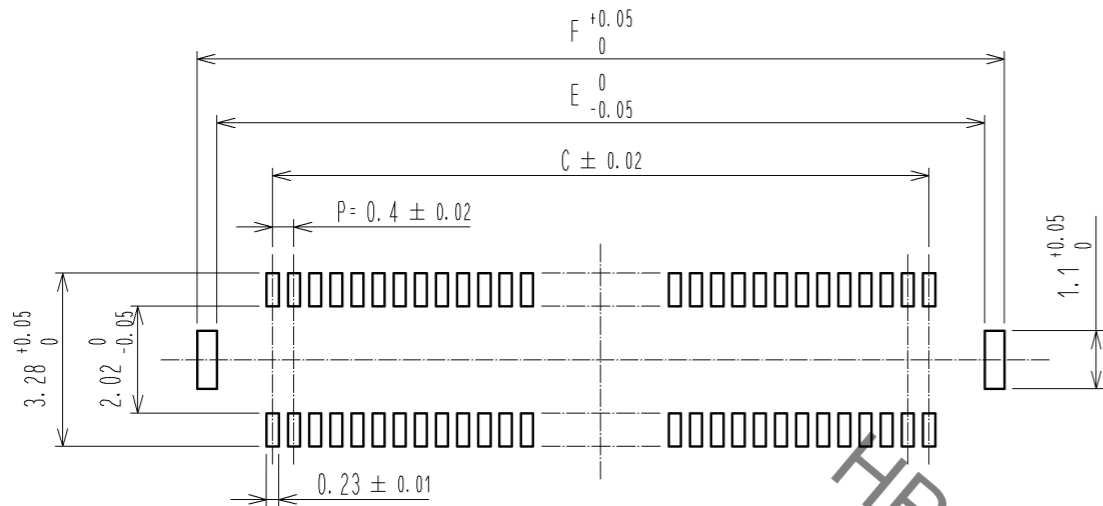

◆ RECOMMENDED METAL MASK DIMENSIONS

METAL MASK THICKNESS : 0.12mm

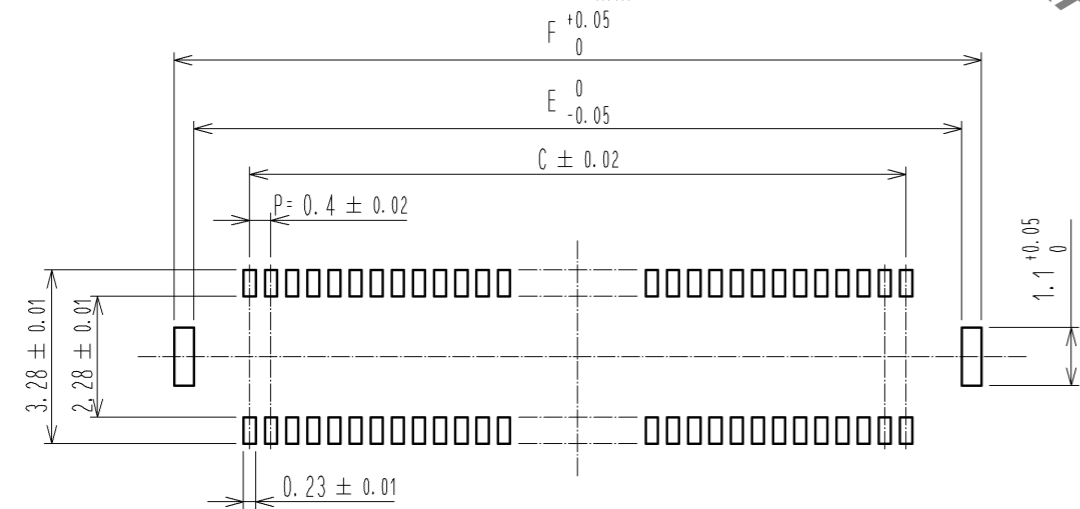

◆ RECOMMENDED METAL MASK DIMENSIONS

METAL MASK THICKNESS : 0.1mm

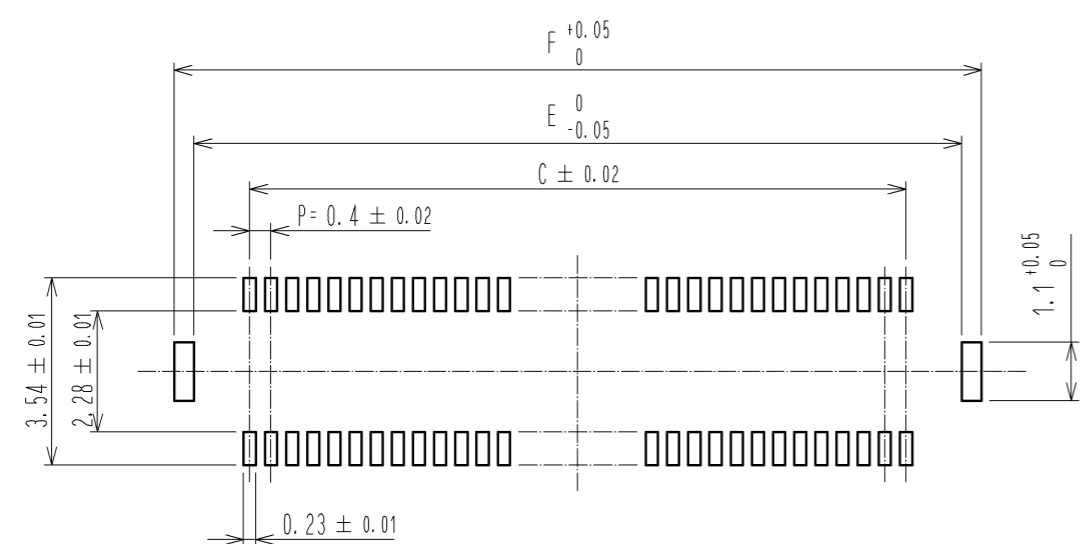

HRS DRAWING FOR REFERENCE

PART No.	C	E	F
DF37NB-10DS-0.4V(51)	1.6	3.7	4.46
DF37NB-16DS-0.4V(51)	2.8	4.9	5.66
DF37NB-20DS-0.4V(51)	3.6	5.7	6.46
DF37NB-24DS-0.4V(51)	4.4	6.5	7.26
DF37NB-30DS-0.4V(51)	5.6	7.7	8.46
DF37NB-34DS-0.4V(51)	6.4	8.5	9.26
DF37NB-40DS-0.4V(51)	7.6	9.7	10.46
DF37NB-44DS-0.4V(51)	8.4	10.5	11.26
DF37NB-50DS-0.4V(51)	9.6	11.7	12.46
DF37NB-60DS-0.4V(51)	11.6	13.7	14.46
DF37NB-70DS-0.4V(51)	13.6	15.7	16.46
DF37NB-74DS-0.4V(51)	14.4	16.5	17.26

4 RECOMMENDED REFLOW TEMPERATURE PROFILE USING LEAD-FREE SOLDER PASTE.

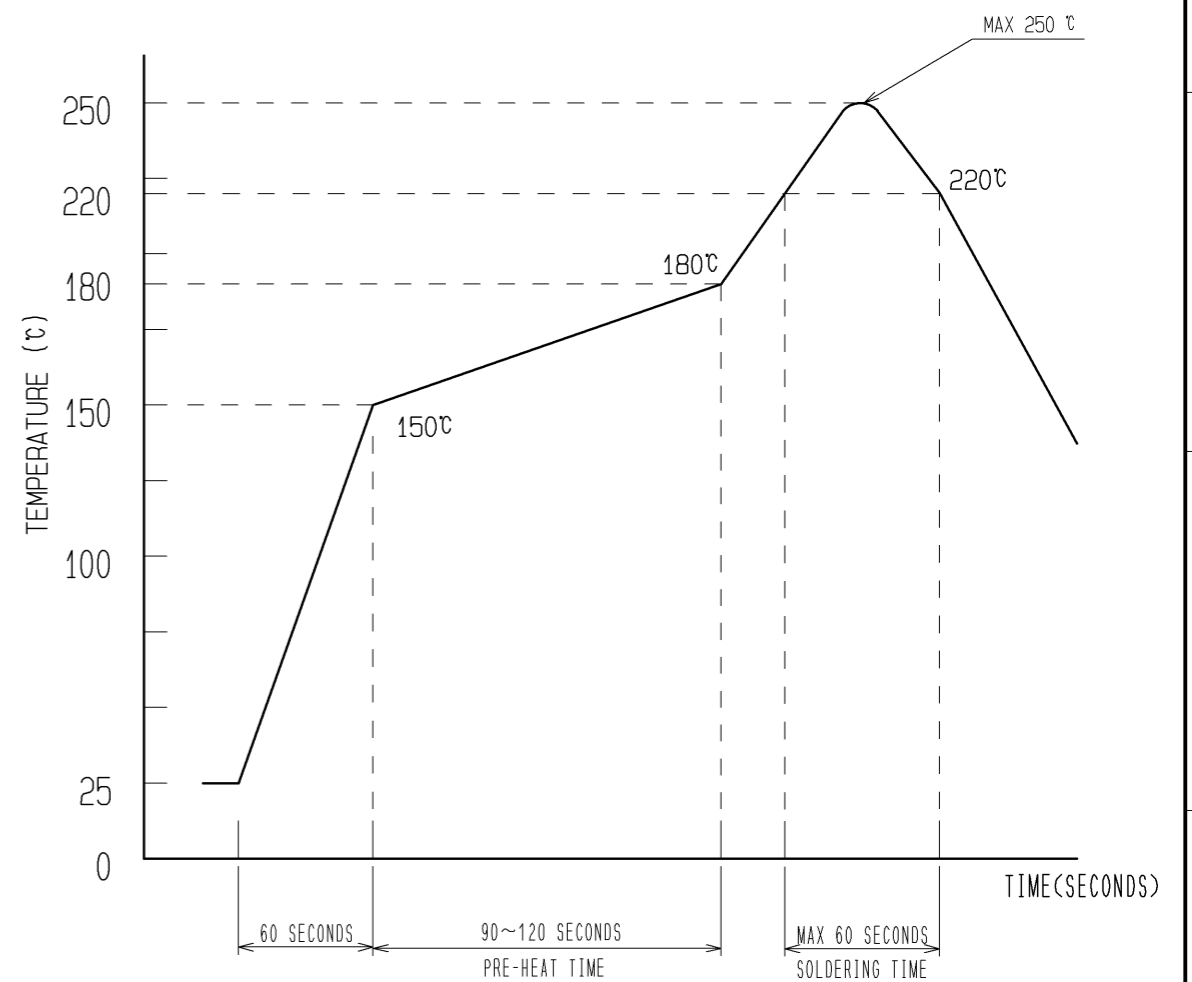

- REFLOW TIME
REFLOW METHOD: IR REFLOW
NUMBER OF REFLOW CYCLES: 2 CYCLES MAX.
DURATION ABOVE 220 °C: 60 SEC. MAX.
(PEAK TEMPERATURE: 250°C MAX.)
- PRE-HEAT TIME
PRE-HEAT TEMPERATURE(MIN) : 150 °C
PRE-HEAT TEMPERATURE(MAX) : 180 °C
PRE-HEAT TIME : 90~120 sec.

4 THIS TEMPERATURE PROFILE IS PER THE CONDITIONS SHOWN ABOVE. ADDITIONAL FACTORS, SUCH AS SOLDER PASTE TYPE, PCB SIZE AND OTHER MOUNTED COMPONENTS COULD AFFECT THE PROFILE. THEREFORE, A THOROUGH EVALUATION OF MOUNTING CONDITION IS REQUIRED PRIOR TO PRODUCTION. TEMPERATURE IS MEASURED AT CONTACT LEAD.

HRS	DRAWING NO.	EDC3-319685-02
	PART NO.	DF37NB-*DS-0.4V(51)
	CODE NO.	

Nov.1.2022 Copyright 2022 HIROSE ELECTRIC CO., LTD. All Rights Reserved.
In case of consideration for using Automotive equipment / device which demand high reliability, kindly contact our sales window correspondents.

EMBOSSED CARRIER TAPE PACKAGING (FREE SIZE)

◆ UNDER 60 POS.

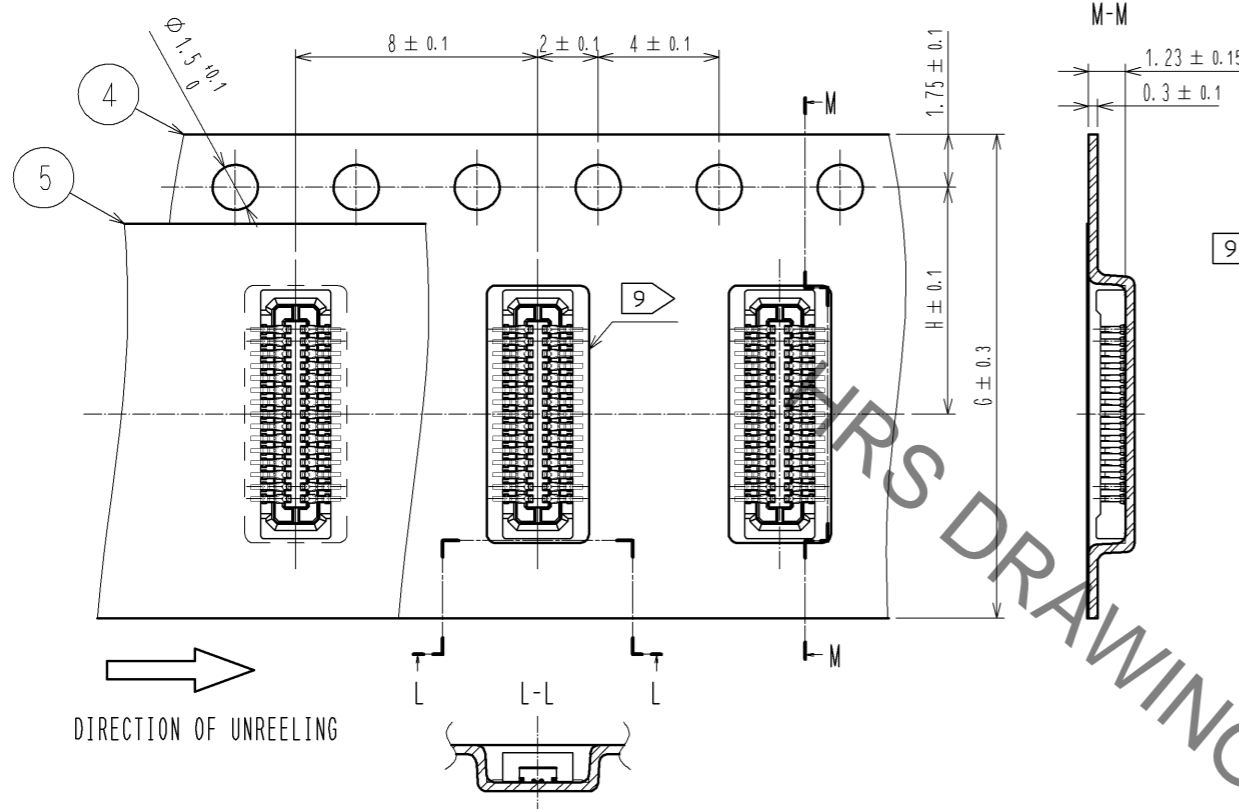

◆ 70 POS. AND ABOVE

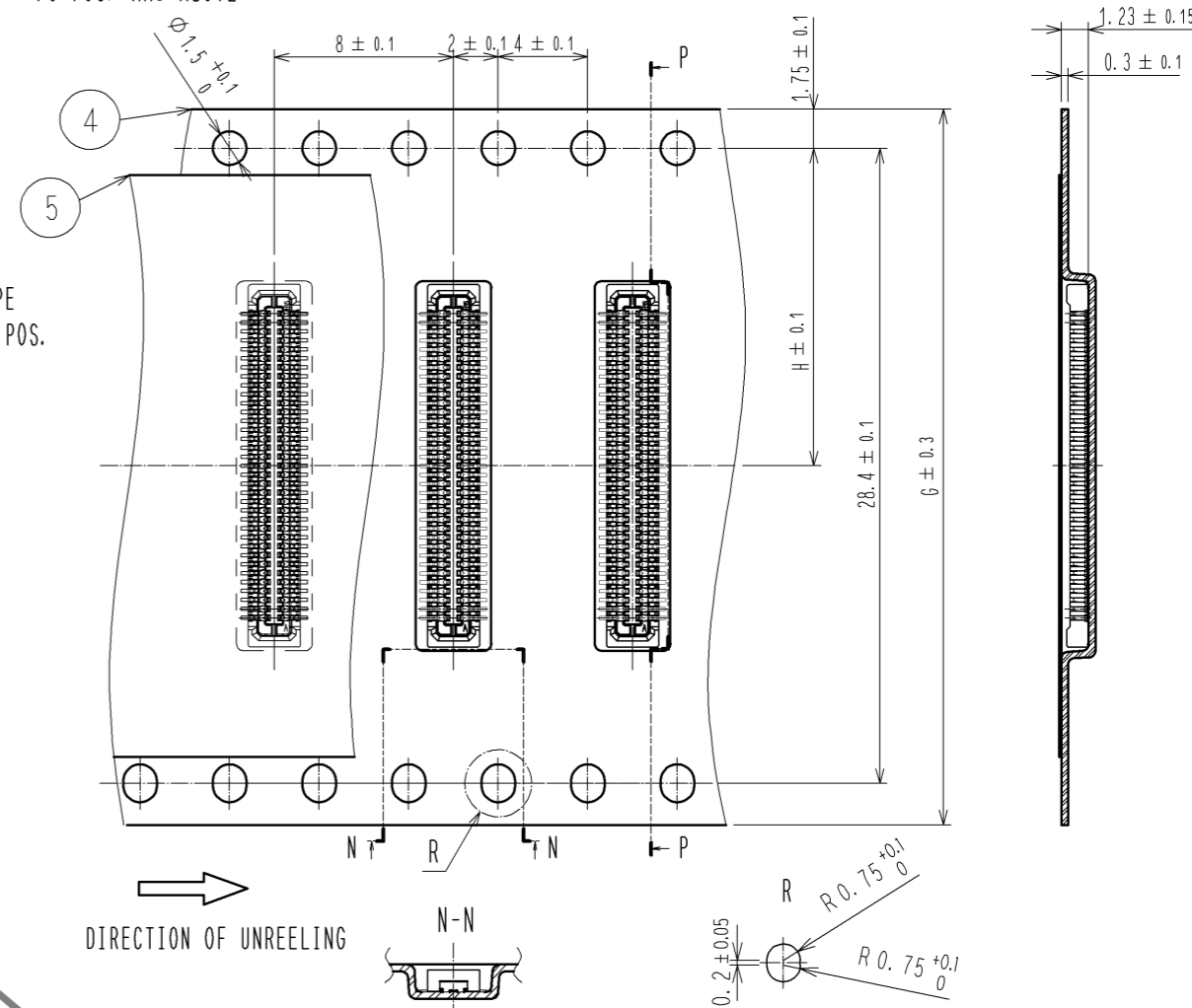

STYLE AND DIMENSION OF REEL (FREE SIZE)

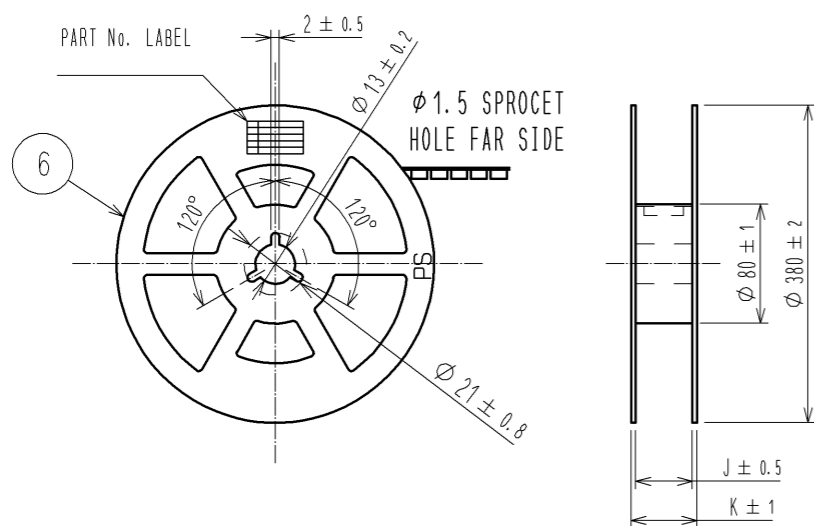

DETAIL OF PART No. LABEL

SUPPLIER	HIROSE ELECTRIC CO., LTD.
QUANTITY	8000
PART NO.	DF37NB-DS-0.4V(51)
CODE NO.	** ** *
DATE OF MANUFACTURED	年 月 日
製造年月日	年 月 日
製品コード	** ** *
製品名	DF37NB-DS-0.4V(51)
数量	8000個
納入者	ヒロセ電機(株)

PART No.	G	H	J	K
DF37NB-10DS-0.4V(51)	16	7.5	17.5	21.5
DF37NB-16DS-0.4V(51)	16	7.5	17.5	21.5
DF37NB-20DS-0.4V(51)	16	7.5	17.5	21.5
DF37NB-24DS-0.4V(51)	16	7.5	17.5	21.5
DF37NB-30DS-0.4V(51)	24	11.5	25.5	29.5
DF37NB-34DS-0.4V(51)	24	11.5	25.5	29.5
DF37NB-40DS-0.4V(51)	24	11.5	25.5	29.5
DF37NB-44DS-0.4V(51)	24	11.5	25.5	29.5
DF37NB-50DS-0.4V(51)	24	11.5	25.5	29.5
DF37NB-60DS-0.4V(51)	24	11.5	25.5	29.5
DF37NB-70DS-0.4V(51)	32	14.2	37.5	33.5
DF37NB-74DS-0.4V(51)	32	14.2	37.5	33.5

NOTES 5. PER REEL 8000 CONNECTORS.

6. THE DIMENSIONS IN PARENTHESSES ARE FOR REFERENCE.

7. REFER TO JIS C 0806(PACKING OF COMPONENTS FOR AUTOMATIC HANDLING)

8. DETAIL OF PART NO. LABEL IS WRITTEN IN JAPANESE.

9. EMBOSS POCKET OF LESS THAN 20 POS. SHALL BE CROSS.

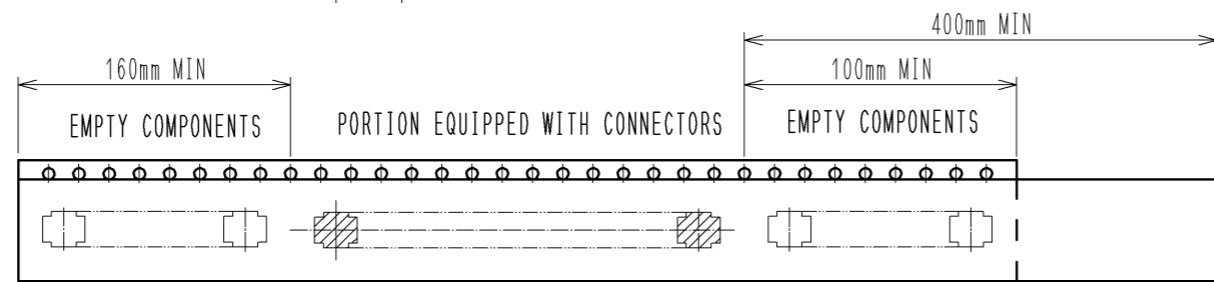

HRS	DRAWING NO.	EDC3-319685-02
	PART NO.	DF37NB-DS-0.4V(51)
	CODE NO.	

3/3