



## PRODUCT SPECIFICATION SHEET

**CUSTOMER** : \_\_\_\_\_

**PRODUCT TYPE** : SMD TSX 2.5×2.0

**NOMINAL FREQ.** : 19.200000 MHz

**FL P/N** : 2Z19200001-Q

**REVISION** : S1

**CUSTOMER P/N** : \_\_\_\_\_

### CUSTOMER'S APPROVAL & DATE

--

### FL CORPORATION

APPROVED	CHECKED	DESIGNED
Jay Lee	Kuro Peng	Chen XuanRu

MSL 1

RoHS Compliant



**CONTENTS**

**PAGE**

• SPECIFICATION REVISION RECORD SHEET	2
• ELECTRICAL SPECIFICATIONS	3 to 4
• CONNECTION DIAGRAM, DIMENSIONS & MARKING	5
• MARKING	6
• SUGGESTED REFLOW PROFILE	6
• STRUCTURE ILLUSTRATION	7
• RELIABILITY TEST SPECIFICATIONS	8
• PACKING	9 to 10
• SPECIFICATION OF THE ENVIRONMENT-RELATED SUBSTANCES	11

**ATTACHMENT (optional)**

- |                                    |   |                          |     |                                     |    |
|------------------------------------|---|--------------------------|-----|-------------------------------------|----|
| • ELECTRICAL CHARACTERISTICS TEST  | A | <input type="checkbox"/> | YES | <input checked="" type="checkbox"/> | NO |
| • TEMPERATURE CHARACTERISTICS TEST | B | <input type="checkbox"/> | YES | <input checked="" type="checkbox"/> | NO |





## PRODUCT DESCRIPTION

### Standard atmospheric conditions

Unless otherwise specified, the standard range of atmospheric conditions for making measurement and tests are as follow:

Ambient temperature : 30±10°C

Relative humidity : 40% to 70%

If there is no doubt the results, measurement shall be made within the following limits:

Ambient temperature : 30±3°C

Relative humidity : 40% to 70%

### Measure equipment

Electrical characteristics are measured by S&A250B or equivalent.

### Crystal cutting type

The crystal is using AT CUT (thickness shear mode).

## ELECTRICAL SPECIFICATIONS

#	Parameters	Symbol	Electrical Spec.			Units	Notes
1	Nominal frequency	FL	19.200000			MHz	-
2	Oscillation mode	-	AT-cut Fundamental			NA	-
3	Load capacitance	CL	-	7	-	pF	(Note 1)
4	Frequency tolerance	-	-10	-	+10	ppm	At 30±3°C
5	Tolerance over temperature (reference 30°C)	-	-12	-	+12	ppm	at -30~+85°C (Note 2)
6	Aging	-	-0.7	-	+0.7	ppm/year	-
7	Frequency drift after reflow	-	-2	-	+2	ppm	after two reflows
8	Operating temperature	-	-30	-	+105	°C	-
9	Storage temperature	-	-40	-	+105	°C	-
10	Equivalent series resistance	ESR	-	-	70	Ω	-
11	Quality factor	Q	75000	-	-		(Note 3)
12	Spurious mode series resistance	-	1100	-	-	Ω	±1MHz
13	Insulation resistance	IR	500	-	-	MΩ	At DC 100V
14	Drive level	DL	10	-	100	μW	-
15	Shunt Capaitance	CO	0.3	-	1.3	pF	-
16	Motional Capacitance	C1	1.8	-	3.1	fF	-
17	First-order curve fitting parameter	-	-0.4	-	-0.1	ppm/°C	(Note 4)
18	Second-order curve fitting parameter	-	-4.5	0	+4.5	×10 <sup>-4</sup> ppm/°C <sup>2</sup>	(Note 4)
19	Third-order curve fitting parameter	-	8.5	10	11.5	×10 <sup>-5</sup> ppm/°C <sup>3</sup>	(Note 4)



### ELECTRICAL SPECIFICATIONS (CONT.)

#	Parameters	Symbol	Electrical Spec.			Units	Notes
20	Residual frequency stability slope	-	-50	-	+50	ppb/°C	(Note 5)
21	5°C small orbit hysteresis 1	-	-50	-	+50	ppb/°C	(Note 6)
22	5°C small orbit hysteresis 2	-	100 (magnitude)			ppb pk-pk	(Note 7)
23	DLD Freq. (Max-Min)	-	-	-	3.0	ppm	(Note 8)
24	DLD Freq. (Repeatability)	-	-	-	0.7	ppm	(Note 8)
25	DLD ESR (Max-Min)	-	-	-	20	%	(Note 8)
26	DLD ESR (Repeatability)	-	-	-	10	%	(Note 8)

Note 1 The load capacitance is measured according to IEC Standard #60444-7.

Note 2 Above 85°C tolerance over temperature bound by third-order coefficient range.

Note 3 Minimum Q value calculated from ESR and L is smaller than this specification.

Note 4 The curve fitting parameter is obtained from the Qualcomm crystal curve fitting algorithm,  $t_0=30\text{ }^\circ\text{C}$   
(Refer to Curve Fitting Calculation Table: 80-V9690-23)

Note 5 Condition 1A – Test condition (continuous temperature rate change of  $\sim 1.0\text{ }^\circ\text{C}/\text{min}$ ):

- Measure FT points every  $1\text{ }^\circ\text{C}$ , heating up from  $-30$  to  $+85\text{ }^\circ\text{C}$ , subtract a fifth-order polynomial best fit and then calculate the slope of the residual.

- The residual slope should be within  $\pm 50$  ppb/°C.

Note 6 Condition 1B – Hysteresis 1 test condition (continuous temperature rate change of  $\sim 1.0\text{ }^\circ\text{C}/\text{min}$ ):

- Measure FT points every  $0.5\text{ }^\circ\text{C}$  while cycling temperature over a  $5\text{ }^\circ\text{C}$  small temperature orbit; an example  $5\text{ }^\circ\text{C}$  small orbit temperature cycle is  $+30\text{ }^\circ\text{C}$  to  $+35\text{ }^\circ\text{C}$  to  $+30\text{ }^\circ\text{C}$ .

- During every individual heating/cooling cycle there should be 11 points; discard the first point of each heating and cooling cycle; this leaves 10 points for the fifth-order polynomial best fit from 1A for each of the 10 points, and then calculate the slope each heating and cooling cycle. Subtract of the residual for each of these heating and cooling 10 point curves.

Note 7 Hysteresis 2 test condition (continuous temperature rate change of  $\sim 1.0\text{ }^\circ\text{C}/\text{min}$ ):

- Measure FT points every  $0.5\text{ }^\circ\text{C}$  while cycling temperature over a  $5\text{ }^\circ\text{C}$  small temperature orbit; an example  $5\text{ }^\circ\text{C}$  small orbit temperature cycle is  $+30\text{ }^\circ\text{C}$  to  $+35\text{ }^\circ\text{C}$  to  $+30\text{ }^\circ\text{C}$ .

- During every individual heating/cooling cycle there should be 11 points; discard the first and last point of each heating and cooling cycle, which results in 9 temperature points. Calculate the average measured peak-to-peak frequency difference for these 9 temperature points.

- The average difference is the magnitude of the small orbit hysteresis 2.

Note 8  $0.01\text{ }^\mu\text{W}$  to  $100\text{ }^\mu\text{W}$  to  $0.01\text{ }^\mu\text{W}$ , number of points: 15 points up and 15 points down = 29 total data points.

Note 9 This crystal specification complies to Qualcomm Mini-Specification 80-V9690-24 Rev. D.

### NTC THERMISTOR SPECIFICATIONS TABLE

#	Parameters	Symbol	Electrical Spec.			Units	Notes
1	Operating Temperature	-	-30	-	+105	°C	
2	Storage Temperature	-	-40	-	+105	°C	
3	Resistance	-	-	100	-	kΩ	At $25\text{ }^\circ\text{C}$
4	B-constant	-	-	4250	-	K	At $25\text{ }^\circ\text{C}$ - $50\text{ }^\circ\text{C}$
5	Tolerance	-	-	-	1	%	



CONNECTION DIAGRAM

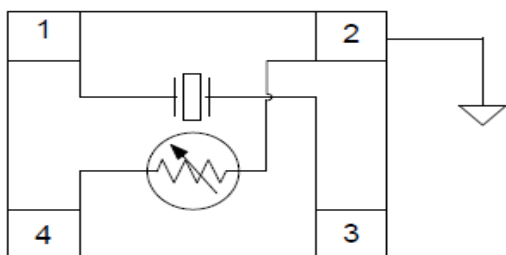

DIMENSIONS (Unit : mm)

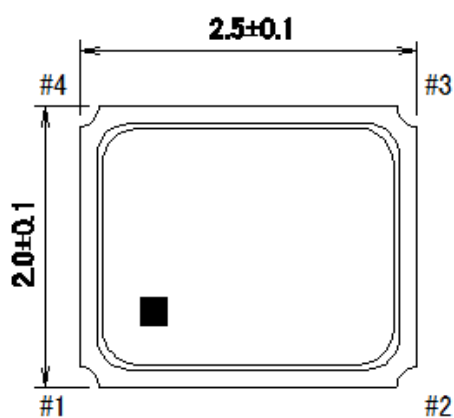

Pad	Function
#1	Xtal terminal (Input)
#2	Thermistor + GND terminal
#3	Xtal terminal (Output)
#4	Thermistor terminal

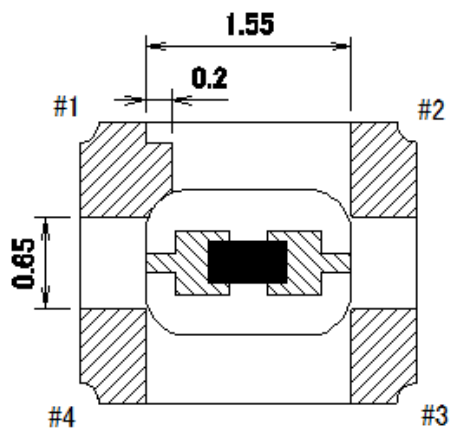

SUGGESTED LAYOUT

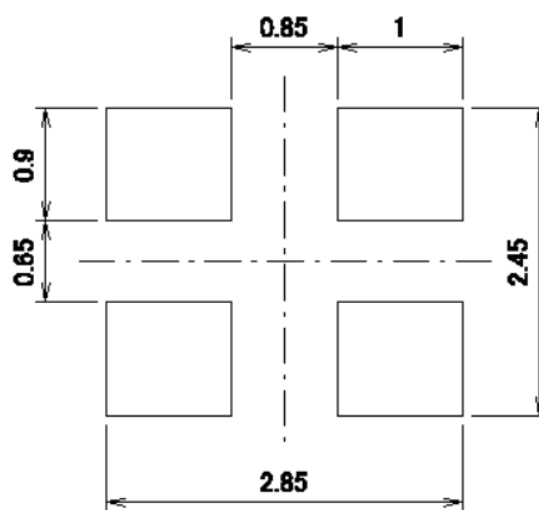



**MARKING**

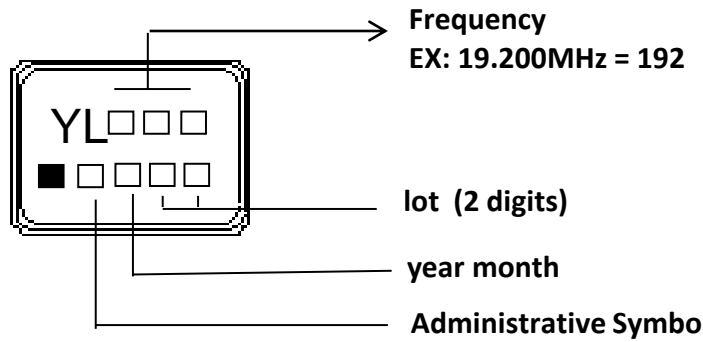

		month											
year		JAN	FEB	MAR	APR	MAY	JUN	JUL	AUG	SEP	OCT	NOV	DEC
2017	2021	A	B	C	D	E	F	G	H	J	K	L	M
2018	2022	N	P	Q	R	S	T	U	V	W	X	Y	Z
2019	2023	a	b	c	d	e	f	g	h	j	k	l	m
2020	2024	n	p	q	r	s	t	u	v	w	x	y	z

**SUGGESTED REFLOW PROFILE**

Total time : 360 sec. Max.

Solder melting point :225 °C

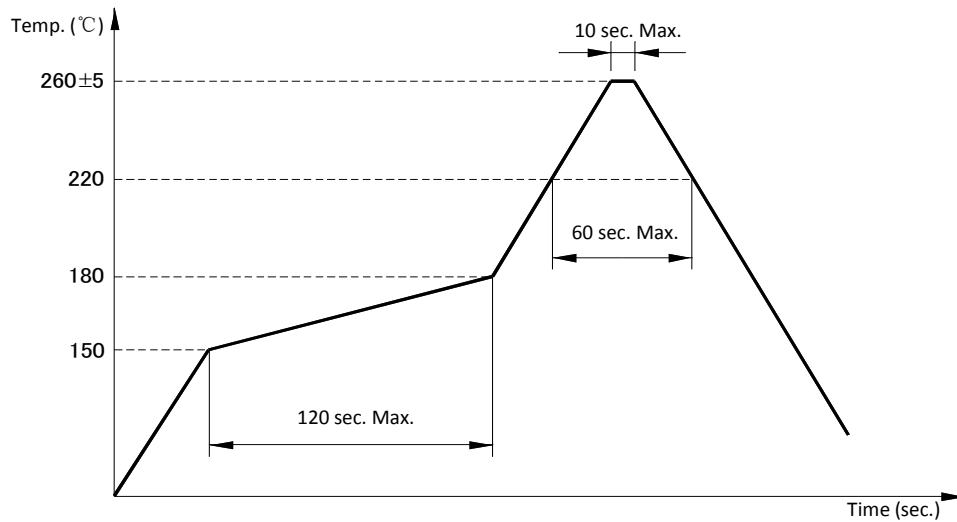



STRUCTURE ILLUSTRATION

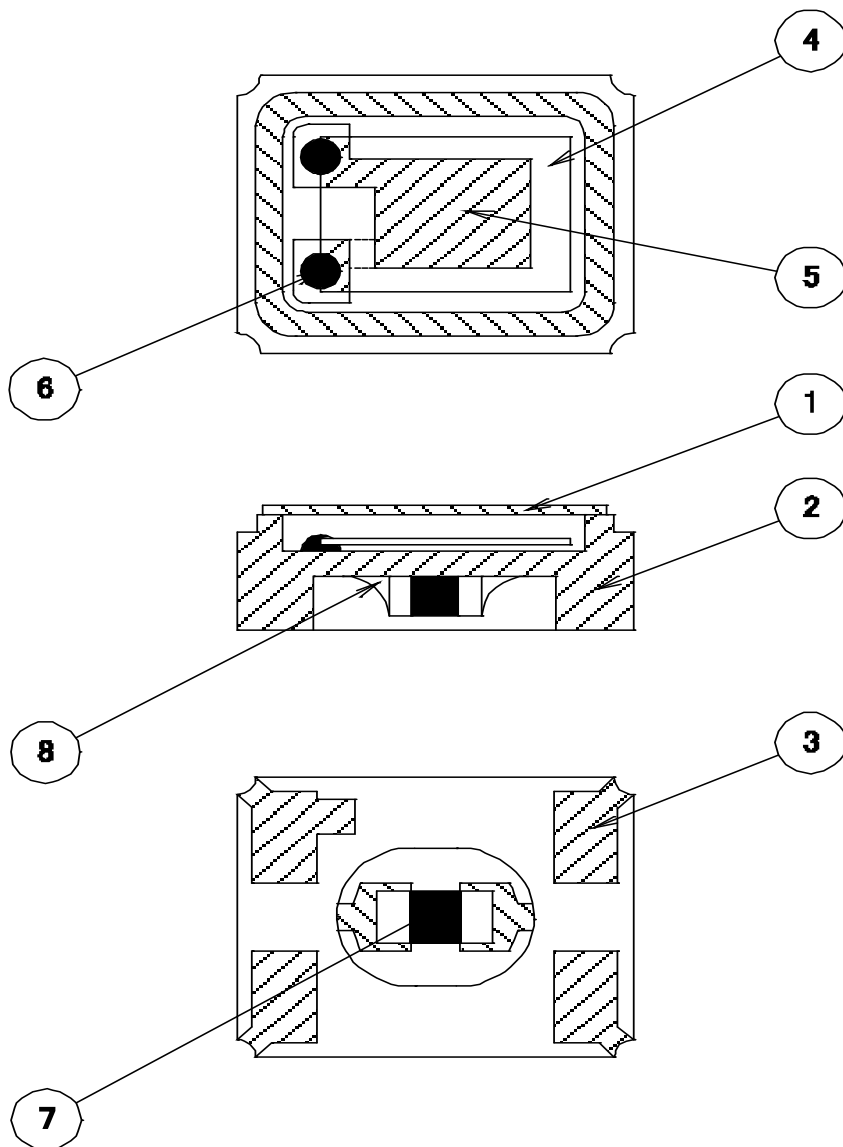

#	COMPONENTS	MATERIALS	QTY	FINISH/SPECIFICATIONS
1	Cap (Lid)	Kovar (Fe+Co+Ni)	1	Ni plating
2	Base (Package)	Alumina Ceramics (Al <sub>2</sub> O <sub>3</sub> ) + Kovar (Fe+Co+Ni)	1	
3	Pad (Package)	Ni + Au	4	
4	Crystal Blank	SiO <sub>2</sub>	1	
5	Electrode	Cr + Nobel material	2	
6	Conductive Adhesive	Ag	2	Silicone resin
7	Thermistor	Alumina Ceramics (Al <sub>2</sub> O <sub>3</sub> ), Ni + Ag+ Sn	1	
8	Solder	Sn + Ag + Cu	2	



## RELIABILITY SPECIFICATIONS

### 1. MECHANICAL ENDURANCE

No.	Test Item	Test Methods	
1	Drop test	150 cm height, fall freely onto stainless plate 3 times.	JIS C6701
2	Shock test	150g/150cm height, 3times in the direction of $\pm x$ , $\pm y$ , $\pm z$ on concrete floor.	IEC-68-02-27
3	Mechanical shock	Device are shocked to half sine wave (1000 G) three mutually perpendicular axes each 3 times. 1.0ms duration time.	MIL-STD-202F
4	Vibration	Frequency range 10 to 55 Hz Amplitude 1.52 mm Perpendicular axes each test time 2 hours (x, y, z axis) Total test time 6 hours	MIL-STD-883E
5	Gross leak	Standard sample for automatic gross leak detector. Test pressure $2\text{kg}/\text{cm}^2$ .	MIL-STD-883E
6	Fine leak	Helium bombing $4.5\text{kgf}/\text{cm}^2$ for 2 hours.	MIL-STD-883E
7	Solderability	Temperature $215^\circ\text{C} \pm 5^\circ\text{C}$ Immersing depth 0.5 mm minimum Immersion time $10 \pm 0.5$ seconds Flux Rosin resin methyl alcohol solvent (1 : 4)	MIL-STD-883E
8	Resistance to soldering heat	Pre-heat temperature $125^\circ\text{C}$ Pre-heat time 60 to 120 sec. Test temperature $260 \pm 5^\circ\text{C}$ Test time $5 \pm 1$ sec.	MIL-STD-202F

### 2. ENVIRONMENTAL ENDURANCE

No.	Test Item	Test Methods	
9	High Temp. storage	$+ 125^\circ\text{C} \pm 3^\circ\text{C}$ for $500 \pm 12$ hours	MIL-STD-883E
10	Low Temp. storage	$- 40^\circ\text{C} \pm 3^\circ\text{C}$ for $500 \pm 12$ hours	
11	Thermal shock	Total 100 cycles of the following temperature cycle <p>The diagram shows a temperature cycle with three levels: <math>125 \pm 3^\circ\text{C}</math>, <math>25^\circ\text{C}</math>, and <math>-55 \pm 3^\circ\text{C}</math>. The cycle consists of a 30 min. dwell at the high temperature, a 10 min. max. ramp down to the low temperature, a 30 min. dwell at the low temperature, and a 10 min. max. ramp up to the high temperature. This sequence is repeated for 100 cycles.</p>	MIL-STD-883E
12	High Temp. & humidity	$85^\circ\text{C} \pm 3^\circ\text{C}$ , RH 85%, 500 hours	JIS C5023



PACKING : (EIA-481-2)

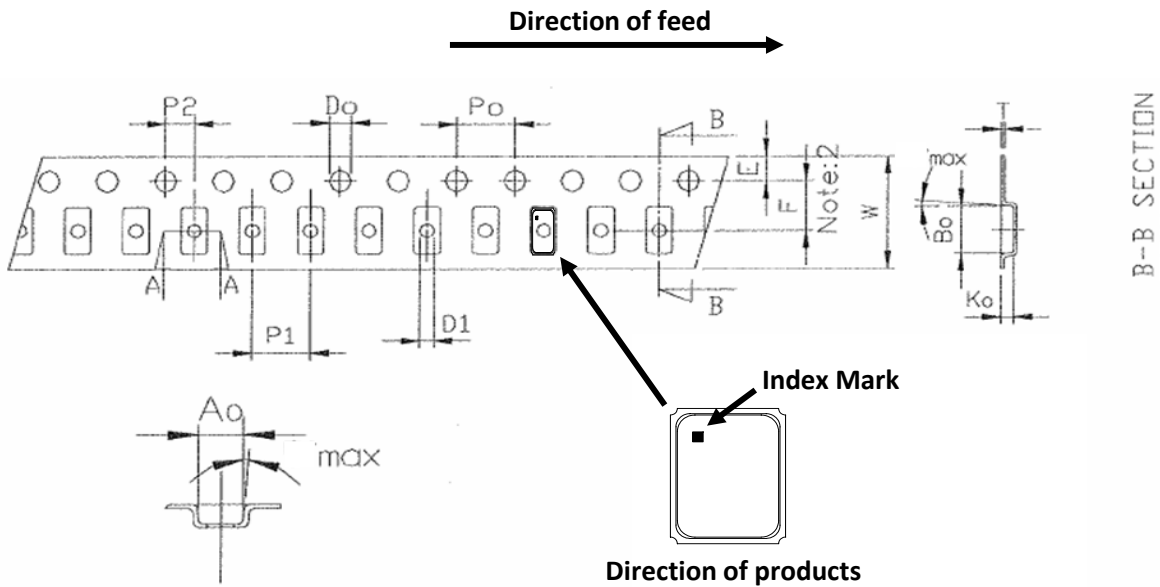

Dimension PKG Type	Unit : mm						
	A0	B0	K0	T	W	E	F
2520 TSX (8mm)	2.25±0.1	2.70±0.1	1.45±0.10	0.25±0.05	8±0.3	1.75±0.1	3.50±0.1
	P1	P2	D1	DO	PO		
	4±0.1	2±0.1	1±0.1	1.55±0.05	4±0.1		

Standard Reel Quantity is 3,000 pcs per reel.

THE INSPECTION FOR TAPE TENSION

ITEM		Defect	Method
Appearance	ALL	1.The tape is not coincidence 2.The bubble	Visual inspection
Tape Tension	8045、7050 6035-12mm 5032-12mm 3225-12mm	overstep 61±6g(55~67g)	Pull test
	3225-8mm	overstep 40±5g(35~45g)	
	2520-8mm	overstep 55±6g(49~61g)	
	2016-8mm	overstep 34±6g(28~40g)	
	1612-8mm	overstep 34±6g(28~40g)	
	6035-16mm 5032-16mm	overstep 60±6g(54~66g)	

REMARK : NA





**SMD PRODUCT PACKING STANDARD**

**Out-going packing instruction**

Reel Packing	Inner Packing	Carton
Name: Reel Standard: Diameter 18cm Material: Plastics Name: Anti-Static Shielding Bag Standard: 205×250mm Material: APET/ CPP	Name: Bubble Wrap Standard: 430×330+20mm Material: HDPE (15 reels enter)	Name: Carton Standard: 400×400×280mm Material: AB corrugated paper (4 bags enter)
		 

**The label instruction**

Label Drawing	Mark	Name of Article	Spec.	Size	Printing
	L1	条码标签 Bar Code Label (Chintz Paper)	1.Part No. 2.Lot No. 3.Q'ty 4.Freq	70x50mm	White
	L2	条码标签 Bar Code Label (Chintz Paper)	1.Part No. 2.Date Code 3.Q'ty 4.Freq	70x50mm	White

**Remark**

Specifications on the label is for the use of templates with different product specifications may vary.  
If customer specified requirements for labels packaging, please provide the operation procedure.



**SPECIFICATION OF THE ENVIRONMENT-RELATED SUBSTANCES**

#	Range	Products	Packing Material
	Banned Substances	Maximum concentration ppm (mg/kg)	Maximum concentration ppm (mg/kg)
1	镉及镉化合物 Cadmium and cadmium compounds	100	100
2	铅及铅化合物 Lead and lead compounds	1000	100
3	汞及汞化合物 Mercury and mercury compounds	1000	100
4	六价铬化合物 Hexavalent-Chromium VI (Cr <sup>+6</sup> )	1000	100
5	聚溴联苯 PBB Polybrominated biphenyls	1000	N/A
6	聚溴二苯醚 PBDE Polybrominated diphenyl ethers	1000	N/A
7	邻苯二甲酸二(2-乙基己基)酯 DEHP Di (2-ethylhexyl) phthalate	1000	N/A
8	邻苯二甲酸丁苄酯 BBP Butyl Benzyl Phthalate	1000	N/A
9	邻苯二甲酸二丁酯 DBP Dibutyl Phthalate	1000	N/A
10	邻苯二甲酸二异丁酯 DIBP Diisobutyl Phthalate	1000	N/A
11	氟(F)、氯(Cl)、溴(Br)、碘(I) Fluorine、Chlorine、Bromine、Iodine	900、900、900、900 注：Br+Cl < 1000	N/A
12	包装材料中重金属(汞、镉、六价铬、铅、PBB、PBDE)之总量 Heavy metals (mercury, cadmium, lead, Cr+6,PBB and PBDE) in packing materials	N/A	100 铅(Pb) + 镉(Cd) + 汞(Hg) + 六价铬(Cr+6) < 100ppm
13	高度关注物质 SVHC-Substances of Very High Concern	1000	N/A



**惠伦晶体**

**FAITH LONG CRYSTAL**