

# 承認書

## SPECIFICATION

Customer : \_\_\_\_\_

Part Name: \_\_\_\_\_ **E-CAP** \_\_\_\_\_

SPEC : \_\_\_\_\_ **RE Series** \_\_\_\_\_

Part NO. : \_\_\_\_\_ **ALL** \_\_\_\_\_

Date : \_\_\_\_\_ **2018-3-3** \_\_\_\_\_

<b>CUSTOMER SIGN</b>	
<b>TOPAZCON</b>	
<b>DRAWING</b>	<b>RATIFY</b>
黃峰	陳慶

**RE Series**

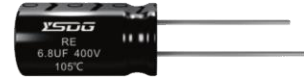

- Standard series for general purpose
- Wide temperature range from -40 °C ~ +105 °C
- Endurance: +105 °C 2,000hours
- RoHS Compliant

**SPECIFICATIONS**

Items	Characteristics												
Category	-40 to +105 °C (6.3 to 100Vdc)						-25 to +105 °C (160 to 500Vdc)						
Temperature Range													
Rated Voltage Range	6.3 to 500Vdc												
Capacitance Tolerance	± 20%(M) (at 20 °C , 120Hz)												
Leakage Current	6.3 to 100Vdc						160 to 500Vdc						Where, I: Max.leakage current( μ A), C: Nominal capacitance( μ F) V: Rated voltage(V) (at 20 °C )
	1 ≤ 0.03CV or 4 μ A (at 1 minute) 1 ≤ 0.01CV or 3 μ A (at 2 minutes) Whichever is greater						CV ≤ 1.000 1 ≤ 0.1CV+40 μ A 1 ≤ 0.03CV+15 μ A CV > 1.000 1 ≤ 0.04CV+100 μ A 1 ≤ 0.02CV+25 μ A						
Dissipation Factor (tan δ)	Rated voltage(Vdc)	6.3	10	16	25	35	50	63	100	160-250	350-400	450	500
	tan δ (Max)	0.26	0.19	0.16	0.14	0.12	0.10	0.09	0.08	0.20	0.24	0.24	0.24
When nominal capacitance exceeds 1,000 μ F, add 0.02 to the value above for each 1,000 μ F increase. (at 20 °C , 120Hz)													
Low Temperature Characteristics (Max.Impedance Ratio)	Rated voltage(Vdc)	6.3	10	16	25	35	50	63	100	160-250	350-400	450	
	Z(-25 °C )/Z(+20 °C )	5	4	3			2			3	6	6	
Endurance	The following specification shall be satisfied when the capacitors are restored to 20 °C after subjected to DC voltage with the rated ripple current is applied for 2,000 hours at 105 °C												
	Capacitance change	≤ ± 20% of the initial value											
D.F. (tan δ)	≤ 200% of the initial specified value												
Leakage current	≤ The initial specified value												
Shelf Life	The following specification shall be satisfied when the capacitors are restored to 20 °C after exposing them for 1,000 hours at 105 °C , without voltage applied												
	Capacitance change	≤ ± 20% of the initial value											
	D.F. (tan δ)	≤ 200% of the initial specified value											
	Leakage current	≤ 200% The initial specified value											

**DIMENSIONS[MM]**

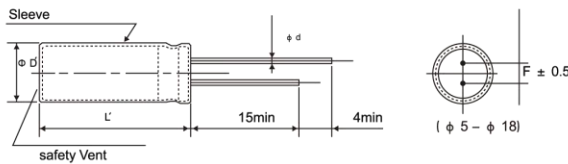

Φ D	5	6.3	8	10	12.5	16	18
Φ d	0.5	0.5	0.5	0.6	0.6	0.8	0.8
F	2.0	2.5	3.5	5.0	5.0	7.5	7.5
Φ D'	Φ D+0.5max						
L'	L+2max						

**RATED RIPPLE CURRENT MULTIPLIERS**

Frequency correction factor for ripple current

Cap(μF)	Freq(Hz)	50	120	300	1k	10k	100k
Cap < 10		0.65	1.00	1.35	1.75	2.30	2.50
10 ≤ Cap < 100		0.75	1.00	1.25	1.50	1.75	1.80
100 ≤ Cap ≤ 1000		0.80	1.00	1.15	1.30	1.40	1.50
Cap > 1000		0.85	1.00	1.03	1.05	1.08	1.08

The endurance of capacitors is shorted with internal heating produced by ripple current at the rate of halving the lifetime with every 5 °C rise. When long life performance is required in actual use, the rms ripple current has to be reduced

**RE Series**

● **STANDARD RATINGS**

WV (Vdc)	Cap (μF)	Case size Φ D × L(mm)	tan δ	Ripple current (mAmps/105 °C, 120Hz)
6.3(OJ)	33	5 × 11	0.26	54
	47	5 × 11	0.26	64
	100	5 × 11	0.26	94
	220	5 × 11	0.26	140
	330	6.3 × 11	0.26	190
	470	6.3 × 11	0.26	230
	1000	8 × 11.5	0.26	380
	2200	10 × 20	0.28	710
	3300	10 × 20	0.30	840
	4700	12.5 × 20	0.32	1090
	6800	12.5 × 25	0.36	1350
	10000	16 × 25	0.44	1650
	15000	16 × 35	0.54	2010
22000	18 × 40	0.68	2350	
10(1A)	22	5 × 11	0.19	46
	33	5 × 11	0.19	57
	47	5 × 11	0.19	68
	100	5 × 11	0.19	100
	220	6.3 × 11	0.19	170
	330	6.3 × 11	0.19	200
	470	8 × 11.5	0.19	250
	1000	10 × 12	0.19	460
	2200	10 × 20	0.21	760
	3300	12.5 × 20	0.23	1000
	4700	12.5 × 25	0.25	1260
	6800	16 × 25	0.29	1570
	10000	16 × 35	0.37	1890
15000	18 × 35	0.47	2180	
16(1C)	10	5 × 11	0.16	34
	22	5 × 11	0.16	51
	33	5 × 11	0.16	63
	47	5 × 11	0.16	75
	100	5 × 11	0.16	110
	220	6.3 × 11	0.16	182
	330	8 × 11.5	0.16	260
	470	8 × 11.5	0.16	310
	1000	10 × 16	0.16	560
	2200	12.5 × 20	0.18	920
	3300	12.5 × 25	0.20	1170
	4700	16 × 25	0.22	1480
	6800	16 × 30	0.26	1780
10000	18 × 35	0.34	2060	
25(1E)	4.7	5 × 11	0.14	25
	10	5 × 11	0.14	36
	22	5 × 11	0.14	54
	33	5 × 11	0.14	67
	47	5 × 11	0.14	80
	100	6.3 × 11	0.14	130
	220	8 × 11.5	0.14	230
	330	8 × 11.5	0.14	310
	470	10 × 12	0.14	380
	1000	10 × 20	0.14	680
	2200	12.5 × 25	0.16	1090
	3300	16 × 25	0.18	1400
	4700	16 × 30	0.20	1710
6800	18 × 35	0.24	2040	

WV (Vdc)	Cap (μF)	Case size Φ D × L(mm)	tan δ	Ripple current (mAmps/105 °C, 120Hz)	
35(1V)	4.7	5 × 11	0.12	28	
	10	5 × 11	0.12	41	
	22	5 × 11	0.12	61	
	33	5 × 11	0.12	75	
	47	5 × 11	0.12	90	
	100	6.3 × 11	0.12	150	
	220	8 × 11.5	0.12	270	
	330	10 × 12	0.12	350	
	470	10 × 16	0.12	460	
	1000	12.5 × 20	0.12	810	
	2200	16 × 25	0.14	1260	
	3300	16 × 35	0.16	1610	
	4700	18 × 35	0.18	1910	
	50(1H)	0.10	5 × 11	0.10	1.3
		0.22	5 × 11	0.10	2.9
0.33		5 × 11	0.10	4.3	
0.47		5 × 11	0.10	6.2	
1.0		5 × 11	0.10	13	
2.2		5 × 11	0.10	20	
3.3		5 × 11	0.10	25	
4.7		5 × 11	0.10	30	
10		5 × 11	0.10	40	
22		5 × 11	0.10	65	
33		6.3 × 11	0.10	90	
47		6.3 × 11	0.10	110	
100		8 × 11.5	0.10	180	
220		10 × 12	0.10	300	
330		10 × 16	0.10	410	
470	10 × 20	0.10	530		
1000	12.5 × 25	0.10	950		
2200	16 × 35	0.12	1470		
3300	18 × 35	0.14	1770		
63(1J)	10	5 × 11	0.09	46	
	22	5 × 11	0.09	71	
	33	6.3 × 11	0.09	100	
	47	6.3 × 11	0.09	120	
	100	10 × 12	0.09	215	
	220	10 × 16	0.09	335	
	330	10 × 20	0.09	510	
	470	12.5 × 20	0.09	640	
	1000	16 × 25	0.09	930	
	100(2A)	0.10	5 × 11	0.08	1.5
0.22		5 × 11	0.08	3.4	
0.33		5 × 11	0.08	5.0	
0.47		5 × 11	0.08	7.1	
1.0		5 × 11	0.08	15	
2.2		5 × 11	0.08	21	
3.3		5 × 11	0.08	29	
4.7		5 × 11	0.08	32	
10		6.3 × 11	0.08	54	
22		8 × 11.5	0.08	93	
33		8 × 11.5	0.08	130	
47		10 × 12	0.08	165	
100		10 × 20	0.08	265	
220		12.5 × 25	0.08	440	

**RE Series**

● STANDARD RATINGS

WV (Vdc)	Cap (μF)	Case size Φ D × L(mm)	tan δ	Ripple current (mA <sub>rms</sub> /105 °C, 120Hz)
100(2A)	330	16 × 25	0.08	540
	470	16 × 30	0.08	715
	1000	18 × 40	0.08	985
160(2C)	3.3	6.3 × 11	0.20	32
	4.7	6.3 × 11	0.20	38
	10	8 × 12	0.20	65
	10	10 × 12	0.20	76
	22	10 × 12	0.20	98
	22	10 × 16	0.20	108
	22	10 × 20	0.20	120
	33	10 × 16	0.20	158
	33	10 × 20	0.20	165
	47	10 × 20	0.20	182
	47	12.5 × 20	0.20	205
	68	12.5 × 20	0.20	265
200(2D)	100	12.5 × 25	0.20	318
	100	16 × 25	0.20	335
	220	16 × 30	0.20	568
	330	18 × 35	0.20	710
	470	18 × 40	0.20	870
	1	6.3 × 11	0.20	16
	2.2	6.3 × 11	0.20	22
	3.3	6.3 × 11	0.20	32
	4.7	8 × 12	0.20	48
	10	8 × 12	0.20	78
	10	10 × 12	0.20	82
	10	10 × 16	0.20	86
	22	10 × 16	0.20	128
	22	10 × 20	0.20	132
	33	10 × 20	0.20	185
	33	12.5 × 20	0.20	194
	47	12.5 × 20	0.20	225
	68	12.5 × 25	0.20	308
82	12.5 × 25	0.20	318	
100	16 × 25	0.20	345	
150	16 × 25	0.20	446	
180	16 × 30	0.20	560	
220	16 × 35	0.20	678	
220	18 × 30	0.20	695	
330	18 × 35	0.20	755	
470	18 × 45	0.20	938	
250(2E)	2.2	6.3 × 11	0.20	22
	3.3	6.3 × 11	0.20	32
	3.3	8 × 12	0.20	34
	4.7	6.3 × 11	0.20	38
	4.7	8 × 12	0.20	48
	10	10 × 12	0.20	75
	10	10 × 16	0.20	84
	22	10 × 20	0.20	128
	22	12.5 × 20	0.20	145
	33	10 × 20	0.20	150
	33	12.5 × 20	0.20	185
	47	12.5 × 20	0.20	232
	47	12.5 × 25	0.20	245
	100	16 × 25	0.20	370
	100	16 × 30	0.20	400
	150	16 × 35	0.20	468
	220	18 × 35	0.20	660
	220	18 × 40	0.20	702
330	18 × 40	0.20	730	

WV (Vdc)	Cap (μF)	Case size Φ D × L(mm)	tan δ	Ripple current (mA <sub>rms</sub> /105 °C, 120Hz)
350(2V)	0.47	6.3 × 11	0.24	11
	1	6.3 × 11	0.24	16
	2.2	8 × 12	0.24	26
	3.3	8 × 12	0.24	34
	3.3	10 × 12	0.24	38
	4.7	8 × 12	0.24	48
	4.7	10 × 12	0.24	52
	10	10 × 12	0.24	68
	10	10 × 16	0.24	82
	10	10 × 20	0.24	88
	22	12.5 × 20	0.24	154
	33	12.5 × 20	0.24	184
	33	16 × 20	0.24	198
	47	16 × 25	0.24	250
400(2G)	68	16 × 25	0.24	335
	100	18 × 30	0.24	398
	1	6.3 × 11	0.24	16
	2.2	6.3 × 11	0.24	30
	2.2	8 × 12	0.24	34
	3.3	8 × 12	0.24	35
	3.3	10 × 12	0.24	38
	4.7	8 × 12	0.24	48
	4.7	10 × 12	0.24	52
	10	10 × 16	0.24	98
	10	10 × 20	0.24	115
	22	12.5 × 25	0.24	192
	33	16 × 20	0.24	258
	47	16 × 25	0.24	305
450(2W)	68	16 × 30	0.24	465
	68	18 × 25	0.24	445
	82	18 × 25	0.24	474
	100	16 × 40	0.24	544
	100	18 × 30	0.24	532
	120	18 × 35	0.24	588
	150	18 × 40	0.24	668
	0.47	8 × 12	0.24	11
	1	8 × 12	0.24	18
	2.2	8 × 12	0.24	25
	2.2	10 × 12	0.24	32
	3.3	10 × 12	0.24	36
	3.3	10 × 16	0.24	40
	4.7	10 × 20	0.24	55
10	10 × 20	0.24	90	
10	12.5 × 20	0.24	100	
22	12.5 × 25	0.24	168	
22	16 × 20	0.24	185	
33	16 × 25	0.24	215	
47	16 × 30	0.24	344	
68	18 × 30	0.24	455	
82	18 × 30	0.24	472	
100	18 × 35	0.24	530	
120	18 × 40	0.24	582	
150	18 × 50	0.24	700	
500(2H)	6.8	10 × 16	0.24	62
	10	10 × 16	0.24	65
	15	12.5 × 16	0.24	70
	22	12.5 × 20	0.24	100
	33	16 × 20	0.24	128
	47	16 × 25	0.24	160

Lead Forming

Taping Specifications

Fig.1 Code:T1

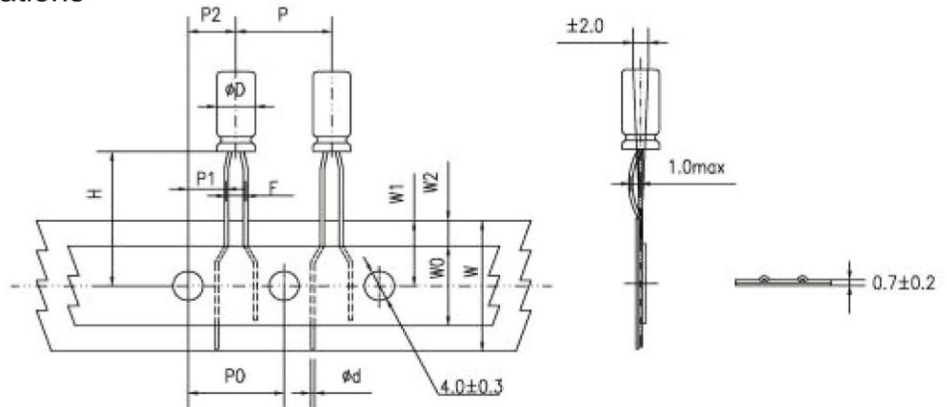

Fig.2 Code:T2

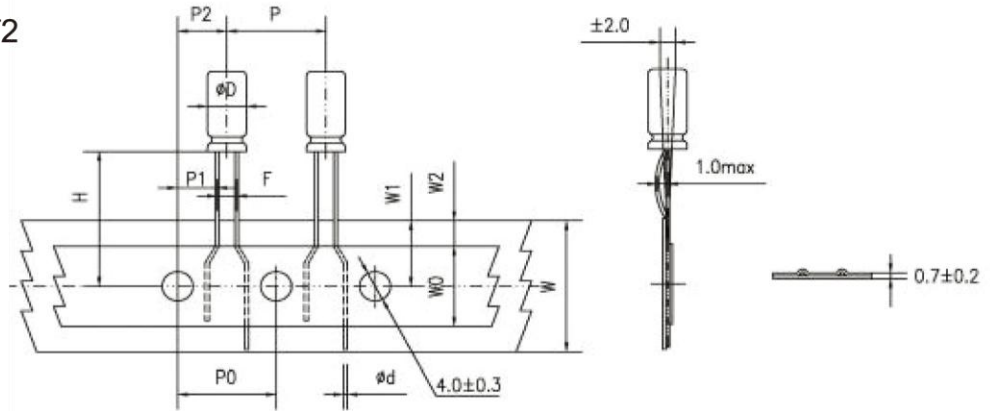

Fig.3 Code:T2

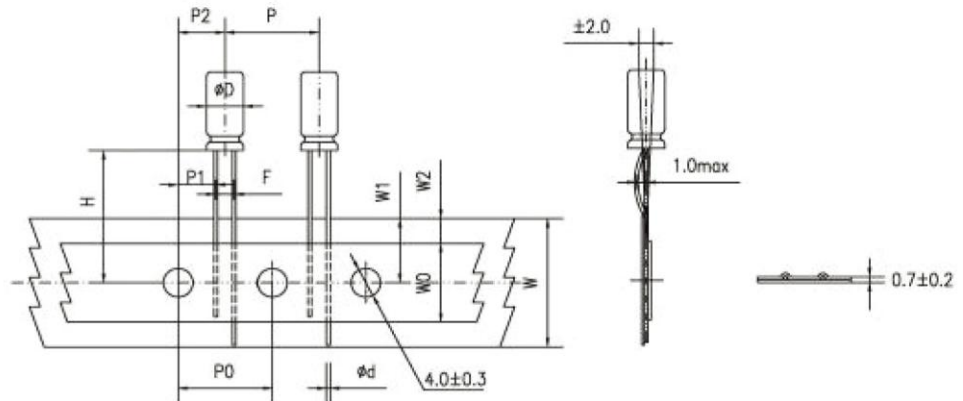
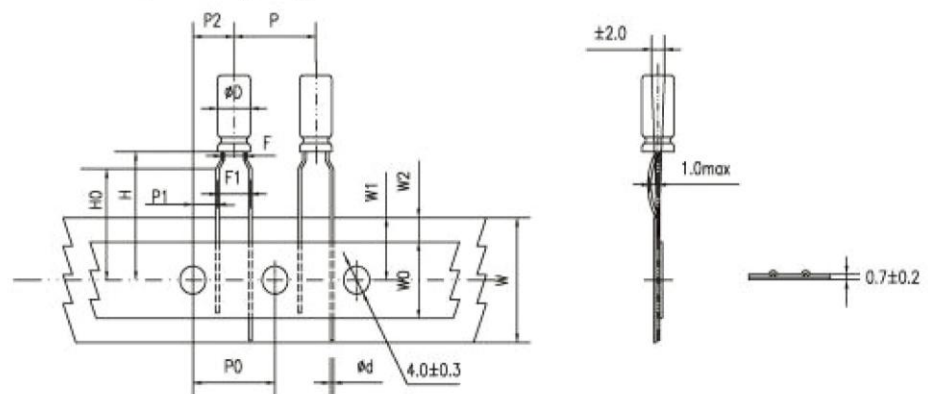

Fig.4 Code:T3



**Specification Fig.1 & Fig.2 & Fig.3**

Items	Symbol	CASE SIZE										Tolerance		
		4 × 5 4 × 7		5 × 5 5 × 7		5×11		6.3×5	6.3×7 6.3×9	6.3×11 6.3×12	8×5/7 8×9/11 8×11.5 8×12		8×16 8×20	10×9/12 10×12.5 10×13/16 10×20/25
Pin Code		T <sub>1</sub>	T <sub>2</sub>	T <sub>1</sub>	T <sub>2</sub>	T <sub>1</sub>		T <sub>2</sub>	T <sub>2</sub>	T <sub>2</sub>	T <sub>2</sub>	T <sub>2</sub>	T <sub>2</sub>	
Lead wire diameter	φd	0.45		0.45		0.5		0.45	0.5	0.5	0.45/0.5	0.6	0.6	± 0.05
Pitch of body	P	12.7		12.7		12.7		12.7	12.7	12.7	12.7	12.7	12.7	± 1.0
Feed hole pitch	PO	12.7		12.7		12.7		12.7	12.7	12.7	12.7	12.7	12.7	± 0.2
Hole center to lead distance	P1	5.1	5.6	5.1	5.35	5.1	5.35	5.1	5.1	5.1	4.6	4.6	3.85	± 0.7
Feed hole center to body center distance	P2	6.35		6.35		6.35		6.35	6.35	6.35	6.35	6.35	6.35	± 1.0
Lead to lead distance	F	2.5	1.5	2.5	2.0	2.5	2.0	2.5	2.5	2.5	3.5	3.5	5.0	± 0.5
Height of body from tape center	H	18.5		18.5		18.5		18.5	18.5	18.5	18.5	18.5	18.5	± 0.75
Base tape width	W	18.0		18.0		18.0		18.0	18.0	18.0	18.0	18.0	18.0	± 0.5
Adhesive tape width	WO	11.0		11.0		11.0		11.0	11.0	11.0	11.0	11.0	11.0	min
Hole positron	W1	9.0		9.0		9.0		9.0	9.0	9.0	9.0	9.0	9.0	+0.75 -0.5
Hole down tape position	W2	3.0		3.0		3.0		3.0	3.0	3.0	3.0	3.0	3.0	max

**Specification Fig.4**

Items	Symbol	CASE SIZE									Tolerance		
		4 × 5 4 × 7	5 × 5	5 × 7	5 × 11	6.3 × 5	6.3 × 7 6.3 × 9	6.3 × 11 6.3 × 12	8 × 5/7 8 × 9/11 8 × 11.5/12	8 × 16 8 × 20			
Pin Code		T <sub>3</sub>	T <sub>3</sub>	T <sub>3</sub>	T <sub>3</sub>	T <sub>3</sub>	T <sub>3</sub>	T <sub>3</sub>	T <sub>3</sub>	T <sub>3</sub>			
Lead wire diameter	φd	0.45		0.45		0.5		0.45	0.5	0.5	0.45/0.5	0.6	± 0.05
Pitch of body	P	12.7		12.7		12.7		12.7	12.7	12.7	12.7	12.7	± 1.0
Feed hole pitch	PO	12.7		12.7		12.7		12.7	12.7	12.7	12.7	12.7	± 0.2
Hole center to lead distance	P1	3.85		3.85		3.85		3.85	3.85	3.85	3.85	3.85	± 0.7
Feed hole center to body center distance	P2	6.35		6.35		6.35		6.35	6.35	6.35	6.35	6.35	± 1.0
Lead to lead distance	F	1.5		2.0		2.0		2.5	2.5	2.5	3.5	3.5	± 0.5
Lead to lead distance	F1	5.0		5.0		5.0		5.0	5.0	5.0	5.0	5.0	+0.8 -0.2
Height of body from tape center	H	18.5		18.5		18.5		18.5	18.5	18.5	18.5	18.5	± 0.75
Lead wire clinch height	HO	16.0		16.0		16.0		16.0	16.0	16.0	16.0	16.0	± 0.5
Base tape width	W	18.0		18.0		18.0		18.0	18.0	18.0	18.0	18.0	± 0.5
Adhesive tape width	WO	11.0		11.0		11.0		11.0	11.0	11.0	11.0	11.0	min
Hole position	W1	9.0		9.0		9.0		9.0	9.0	9.0	9.0	9.0	+0.75 -0.5
Hole down tape position	W2	3.0		3.0		3.0		3.0	3.0	3.0	3.0	3.0	max

TEL: 86-769-85391636 / 85391626 FAX: 86-769-85325630

http://www.songshengdg.com E-mail:songshengcw@163.com

廣東省東莞市大朗鎮佛子凹村佛富路三號 郵編：523781

● Lead Forming & Cut:

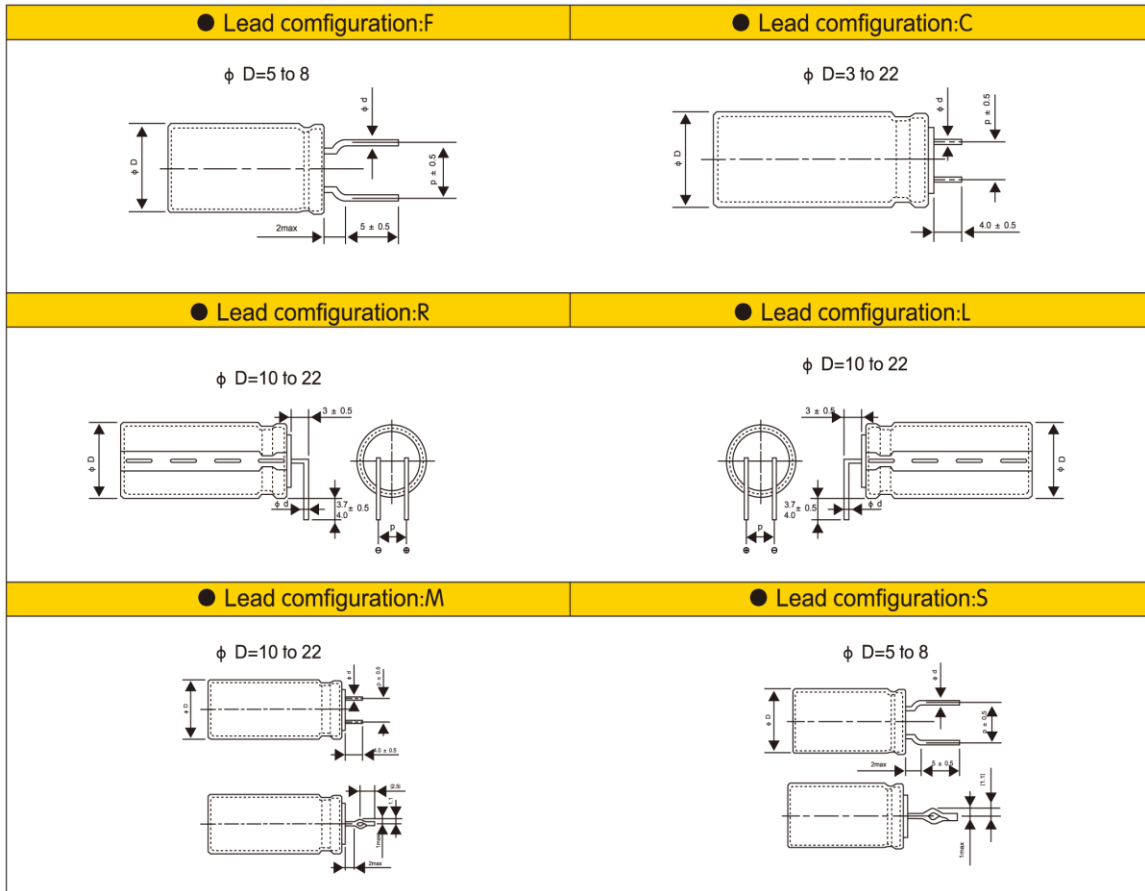

● LEAD SPACING&RECOMMENDED PCB DIMENSIONS

(mm)

Dimension	$\phi d$	p	PC Board		Lead Configuration
			Hole diameter	Thickness	
5	0.5	5.0	0.8	1.6	F C S
6.3	0.5	5.0	0.8		
8	0.5/0.6	5.0	1.0		
10	0.6	5.0	1.0	1.6	C M R L
12.5	0.6	5.0	1.0		
16	0.8	7.5	1.2		
18	0.8	7.5	1.2		
20	0.8	7.5	1.2		
22	0.8	10.0	1.2		

TEL: 86-769-85391636 / 85391626 FAX: 86-769-85325630

http://www.songshengdg.com E-mail:songshengcw@163.com

廣東省東莞市大朗鎮佛子凹村佛富路三號 郵編：523781

● Lead configuration:B

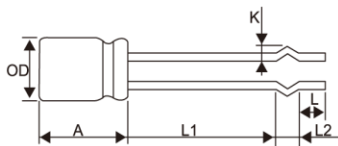

∅D	L1	L2	K	A	L	
5	17.5-19.5	2.6	1.9	10.0-15.0	3.0-5.0	
6.3	17.5-19.5	2.6	1.9	10.0-16.0		
8	12.0-14.0	2.5	1.3	10.0-20.0		
8	13.5-15.5	2.5	1.5			
8	13.0-15.0	3.0	1.5			
8	19.5-21.5	3.0	1.5			
8	21.0-23.0	3.0	1.5			
10	7.5-9.5	2.5	1.7	10.0-25.0		
10	17.0-19.0	2.5	1.7			
10	10.5-12.5	2.5	1.5			
10	10.0-12.0	3.0	1.5			
10	13.0-15.0	3.0	1.5			
10	18.0-20.0	3.0	1.5			
10	21.0-23.0	3.0	1.5			
	± 1.0	± 0.5	0.3	± 1.0		± 1.0

● Lead configuration:K

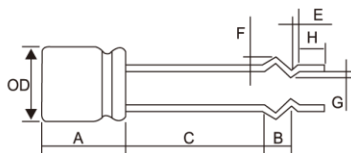

∅D	C	B	E	F	G	A	H
8	13.5-15.5	3	1.2	1.8	0.8	10-20	3.0-5.0
10	18.5-20.5	3	1.2	1.8	1	10-25	
10	19.0-21.0	3	1.5	1.4	0.5		
	± 1.0	± 0.5	± 0.3	± 0.3	± 0.3	± 1.0	± 1.0

## 鋁電解電容器的使用注意事項

### Guidelines For Using Aluminum Electrolytic Capacitor

為使客戶獲得電解電容器的最佳性能和延長電解電容器的使用壽命，在使用電解電容器前，請務必閱讀本注意事項。

Upon using Aluminum Electrolytic Capacitors, please proper handling and observing to following important points will insure optimum capacitor performance and long life.

1、直流電解電容器是有極性的 DC electrolytic capacitors are polarized.

確定極性，極性標誌在電容器的基體上。以免因極性反可能引起電路短路或電容器損壞，當極性不固定或不確定的，使用雙極性電容器。注意直流電解電容器不能使用於交流。

Make sure of the polarity .The polarity is marked on the body of the capacitor .Application of the reversed voltage may cause a short circuit or damage to the capacitor. Use bipolar capacitors when the polarity is not determined or unknown. Note that DC electrolytic capacitors can not be used for AC application.

2、雙極性電容器

Bipolar capacitors

只適用於脈動電路和極性反轉電路中，不適用於純交流和高紋波電路中。

They are used only in pulse circuits as well as polarity reverse circuits. but not applicable in pure AC or high ripple current.

3、使用電壓不要大於額定電壓 DO not apply voltage greater than rated voltage .

使用電壓大於額定電壓，漏電流會增大，可能損壞電容器。建議工作電壓為額定電壓的百分之七十~八十，電容器在建議的工作電壓下使用可延長電容器的壽命。

If a voltage exceeding the rated voltage is applied , the leakage current will increase ,which damage the capacitor. Recommended working voltage is 70 to 80 percent of rated voltage. Using capacitors at recommended working voltage prolongs capacitor life.

#### 4、不要使過量的紋波電流通過電容器

Do not allow excessive ripple current through the capacitor.

流過電容器的紋波電流超過許可值，將會引起電容器發熱，電容量減少，損害電容器。通過電容器的紋波電流不要大於允許值，一般不超過額定值的 80%。

The flow of ripple current over permissible ripple current will cause heat of the capacitor, which may decrease the capacitance and damage the capacitor. ripple current on the capacitor must be at or bellow allowable level, generally not more than 80% of the rated current.

#### 5、快速的充放電電路中，使用專門設計的電容器

Use specially designed capacitors for the circuits where charge and discharge are frequency repeated.

在經受快速的週期性充放電電路中，電容器可能受損害，它的壽命因容量下降、溫升等原因而縮短，在這種電路中，一定要使用專門設計的電容器。

In the circuit subjected to rapid charge and discharge cycles, capacitors may be damaged, its life may be shortened by capacitance decrease, heat rise, ect. Be sure and use special capacitors in these applications.

#### 6、工作溫度範圍 Operating temperature range.

電容器的特性隨工作溫度而變化，在溫度較高的情況下，容量、漏電流增大， $\text{tg } \delta$  減少；在低溫情況下，容量和漏電流下降， $\text{tg } \delta$  增大。電容器在較低的溫度下使用會確保延長壽命。

The characteristics of capacitors change with the operating temperature. The capacitance and leakage current increase and  $\text{tg } \delta$  decrease at higher temperatures. The capacitance and leakage current decrease and  $\text{tg } \delta$  increase at lower temperature. Usage at lower temperature will ensure longer life.

7、使用溫度與壽命的關係 Relationship between temperature and life.

電容器的壽命與其使用的溫度有關，一般來說，使用溫度降低 10°C，其壽命是額定溫度下的 2 倍，計算公式如下：

Life of capacitors has relationship with its used temperature .Generally, if the used temperature is reduced 10°C ,life is prolonged twice at rated temperature. Here is calculating format:

$$LS = LO \times 2^{\frac{T_0 - T_x}{10}} \times 2^{\frac{\Delta T_m - \Delta T_m \left( \frac{I_x}{I_0} \right)^2}{10}}$$

L0: Useful life when applied ripple current Istd at maximal operating temperature T0,H

T0: Maximum Operating Temperature .

Tx: Actual Operating Temperature.

ΔTm: 5°C

Ix: Actual Ripple Current

I0: Rated Ripple Current.

8、核對工作頻率 Check operating frequency.

電解電容器的電容量通常是在 100Hz 或 120Hz 下測得的。然而要記住容量隨頻率的升高而下降，tg δ 隨頻率的升高而增大，並使周圍溫度升高。

The capacitance of electrolytic capacitors is usually measured at 100Hz or 120Hz. However , remember that capacitance decrease and tg δ increase as the applied frequency becomes higher whereas the ambient temperature becomes higher.

9、長時間存放的電容器，在使用前加額定直流電壓處理 Apply rated DC voltage treatment to the capacitors which have been stored for a long time.

長時間的存放，實際對電容器的容量和 tg δ 沒有多大的影響，然而往往會使漏電流增大，耐壓降低。

長時間存放後的電容器處理，首先逐漸施加直流電壓至額定電壓，然後再使用。

Long periods of storage have virtually no effect no a capacitor' s capacitance and tg δ. Such periods tend, however, to increase leakage current and decrease withstand voltage.

After removing capacitors from long-duration storage, First apply a gradually increasing DC voltage to rated voltage and then use them.

10、電容器外殼與陰極端是不絕緣的 The capacitor case is not insulated from the cathode terminal.

電容器的外殼與陰極端是通過電解液連接的，如果電容器的外殼必須與線路絕緣，則電容器的安裝位置處，一定要採取絕緣措施。

The capacitor's case and cathode terminal connect through the electrolyte. If the case is to be completely insulated, that insulation must be at the capacitor's mounting point.

11、電容器的端子或引線不要施加過大的力

Do not apply excessive force to the terminals and leads.

過大的力施加到端子或引線上，可能引起引線的斷裂或端子分裂，轉而會引起內部連接的破壞。

The excessive strong force applied to the terminals and lead wires may cause leads to break or terminals to separate and, in turn, cause the internal contact to fail.

12、如電容器需彎腳成臥式狀態。彎腳處應與電容器成體保持 2mm 的安全間距，否則可能造成電容器內部結構損傷。

Such as capacitor to bend feet into horizontal state. Bending feet should maintain with capacitor adult 2mm safe spacing, otherwise may cause the internal of capacitor structural damage

13、浸焊料後，線路板的清洗 Cleaning of the circuit board after solder dipping.

清洗線路板以去除焊劑或其它附著物。爲了保護塑膠套管，印刷標誌以及封口材料不被破壞，電容器不能用鹵化物或類似溶劑作爲電容器清洗用，如三氯乙烯，二甲苯或酮類等。建議使用的清洗溶劑爲：甲醇，異丙醇，乙醇，異丁醇，石油醚，丙醇和一般的洗滌劑。

Cleaning circuit boards to remove flux or other extraneous matter. To ensure protection for sleeve, marking and sealing materials on capacitor body, capacitor should never be washed or cleaned by halogens agents or solvents such as trichlorethylene, xylem or acetone etc. Recommended cleaning solvents. Methanol, isopropanol ethanol, isobutanol, petroleumthe, propane and/or commercial detergents.

14、焊接時注意溫度和持續的時間 Be cautious of the temperature and duration when soldering.

烙鐵應與電容器的塑膠絕緣套管保持一定的距離。當電容器浸于焊料槽時，建議溫度在 260°C 以內，時間不要超過 10 秒鐘，以避免電容器元件受損。

Soldering irons should be kept away from the vinyl insulated sleeves of capacitor. When the capacitor dipped in solder bath, recommendable within 260°C and 10 seconds to avoid damage of capacitor unit.

#### 15、印刷線路板上孔的佈局

Hole positions on the circuit board.

設計印刷線路板時，安裝孔距應等於引線間距，當孔距大於或小於引線間距時，安裝電容器時，將有應力作用到引線上，可能引起短路，電路損壞，漏電流增大。

另外，焊料可能通過所打的孔及後加工零件的引線孔濺落到塑膠套管上，造成損傷，所以要認真考慮孔的佈局。

When designing a circuit board, space the position holes equally to the space between lead wires. When the spacing is either greater than or less than the capacitor's leads, mounting the capacitor will apply to the leads, causing short circuits, broken circuits, and increased current.

Otherwise, through-holes on the circuit board as well as lead holes of post-process parts can result in solder splashing onto the vinyl sleeve, causing damage. Consider hole positions carefully.

## Test Report

No. SZXEC1700253401

Date: 10 Apr 2017

Page 1 of 13

GUANGDONG TOPAZ ELECTRONIC TECHNOLOGY CO.,LTD

3 INDUSTRY FACTORY,FU ZI AO VILLAGE FU FU ROAD,DALANG TOWN,DONGGUAN,CHINA  
DONGGUAN SONGSHENG ELECTRONICS CO.,LTD.

3 INDUSTRY FACTORY,FU ZI AO VILLAGE FU FU ROAD,DALANG TOWN,DONGGUAN,CHINA

The following sample(s) was/were submitted and identified on behalf of the clients as : Aluminum electrolytic capacitor

SGS Job No. : RP17-002586 - SZ

Date of Sample Received : 31 Mar 2017

Testing Period : 31 Mar 2017 - 06 Apr 2017

Test Requested : Selected test(s) as requested by client.

Test Method : Please refer to next page(s).

Test Results : Please refer to next page(s).

Conclusion : Based on the performed tests on selected part of submitted sample(s), the results of Cadmium, Lead, Mercury, Hexavalent chromium, Polybrominated biphenyls (PBBs), Polybrominated diphenyl ethers (PBDEs) do not exceed the limits as set by RoHS Directive (EU) 2015/863 amending Annex II to Directive 2011/65/EU.

Signed for and on behalf of  
SGS-CSTC Standards Technical Services Co., Ltd. Shenzhen Branch



Sunny Nie  
Approved Signatory



Unless otherwise agreed in writing, this document is issued by the Company subject to its General Conditions of Service printed overleaf, available on request or accessible at <http://www.sgs.com/en/Terms-and-Conditions.aspx> and, for electronic format documents, subject to Terms and Conditions for Electronic Documents at <http://www.sgs.com/en/Terms-and-Conditions/Terms-e-Documents.aspx>. Attention is drawn to the limitation of liability, indemnification and jurisdiction issues defined therein. Any holder of this document is advised that information contained hereon reflects the Company's findings at the time of its intervention only and within the limits of Client's instructions, if any. The Company's sole responsibility is to its Client and this document does not exonerate parties to a transaction from exercising all their rights and obligations under the transaction documents. This document cannot be reproduced except in full, without prior written approval of the Company. Any unauthorized alteration, forgery or falsification of the content or appearance of this document is unlawful and offenders may be prosecuted to the fullest extent of the law. Unless otherwise stated the results shown in this test report refer only to the sample(s) tested.

Attention: To check the authenticity of testing / inspection report & certificate, please contact us at telephone: (86-755) 8307 1443, or email: CN.Doccheck@sgs.com

SGS-CSTC Standards Technical Services Co., Ltd.  
Shenzhen Branch Testing Center-Chemical Laboratory

SGS Bldg, No.3, Jianghao Industrial Park, No.430, Jihua Road, Banliao, Longgang District, Shenzhen, China 518129 t (86-755) 25328888 f (86-755) 83106190 www.sgsgroup.com.cn  
中国·深圳·龙岗区坂田吉华路430号江灏工业园3栋SGS大楼 邮编: 518129 t (86-755) 25328888 f (86-755) 83106190 e sgs.china@sgs.com

Test Results :

Test Part Description :

Specimen No.	SGS Sample ID	Description
SN1	SZX17-002534.001	Lt-yellow liquid(semi-product)
SN2	SZX17-002534.002	Transparent adhesive plastic tape(semi-product)
SN3	SZX17-002534.003	Silvery metal pin(semi-product)
SN4	SZX17-002534.004	Grey metal sheet 4#(semi-product)
SN5	SZX17-002534.005	Silvery metal(semi-product)
SN6	SZX17-002534.006	Black plastic(semi-product)
SN7	SZX17-002534.007	Yellow plastic w/ black printing(semi-product)
SN8	SZX17-002534.008	Lt-brown paper(semi-product)
SN9	SZX17-002534.009	Grey metal sheet 9#(semi-product)

Remarks :

- (1) 1 mg/kg = 1 ppm = 0.0001%
- (2) MDL = Method Detection Limit
- (3) ND = Not Detected ( < MDL )
- (4) "-" = Not Regulated

**RoHS Directive (EU) 2015/863 amending Annex II to Directive 2011/65/EU**

- Test Method :
- (1)With reference to IEC 62321-5:2013, determination of Cadmium by ICP-OES.
  - (2)With reference to IEC 62321-5:2013, determination of Lead by ICP-OES.
  - (3)With reference to IEC 62321-4:2013, determination of Mercury by ICP-OES.
  - (4)With reference to IEC 62321:2008, determination of Hexavalent Chromium by Colorimetric Method using UV-Vis.
  - (5)With reference to IEC 62321-6:2015, determination of PBBs and PBDEs by GC-MS.
  - (6)With reference to IEC 62321-8:2013 (111/321/CD) , determination of phthalates by GC-MS.

Test Item(s)	Limit	Unit	MDL	001	002	006
Cadmium (Cd)	100	mg/kg	2	ND	ND	ND
Lead (Pb)	1,000	mg/kg	2	ND	ND	ND
Mercury (Hg)	1,000	mg/kg	2	ND	ND	ND
Hexavalent Chromium (CrVI)	1,000	mg/kg	2	ND	ND	ND
Sum of PBBs	1,000	mg/kg	-	ND	ND	ND
Monobromobiphenyl	-	mg/kg	5	ND	ND	ND
Dibromobiphenyl	-	mg/kg	5	ND	ND	ND
Tribromobiphenyl	-	mg/kg	5	ND	ND	ND



Unless otherwise agreed in writing, this document is issued by the Company subject to its General Conditions of Service printed overleaf, available on request or accessible at <http://www.sgs.com/en/Terms-and-Conditions.aspx> and, for electronic format documents, subject to Terms and Conditions for Electronic Documents at <http://www.sgs.com/en/Terms-and-Conditions/Terms-e-Documents.aspx>. Attention is drawn to the limitation of liability, indemnification and jurisdiction issues defined therein. Any holder of this document is advised that information contained hereon reflects the Company's findings at the time of its intervention only and within the limits of Client's instructions, if any. The Company's sole responsibility is to its Client and this document does not exonerate parties to a transaction from exercising all their rights and obligations under the transaction documents. This document cannot be reproduced except in full, without prior written approval of the Company. Any unauthorized alteration, forgery or falsification of the content or appearance of this document is unlawful and offenders may be prosecuted to the fullest extent of the law. Unless otherwise stated the results shown in this test report refer only to the sample(s) tested.

Attention: To check the authenticity of testing / inspection report & certificate, please contact us at telephone: (86-755) 8307 1443, or email: CN.Doccheck@sgs.com

# Test Report

No. SZXEC1700253401

Date: 10 Apr 2017

Page 3 of 13

Test Item(s)	Limit	Unit	MDL	001	002	006
Tetrabromobiphenyl	-	mg/kg	5	ND	ND	ND
Pentabromobiphenyl	-	mg/kg	5	ND	ND	ND
Hexabromobiphenyl	-	mg/kg	5	ND	ND	ND
Heptabromobiphenyl	-	mg/kg	5	ND	ND	ND
Octabromobiphenyl	-	mg/kg	5	ND	ND	ND
Nonabromobiphenyl	-	mg/kg	5	ND	ND	ND
Decabromobiphenyl	-	mg/kg	5	ND	ND	ND
Sum of PBDEs	1,000	mg/kg	-	ND	ND	ND
Monobromodiphenyl ether	-	mg/kg	5	ND	ND	ND
Dibromodiphenyl ether	-	mg/kg	5	ND	ND	ND
Tribromodiphenyl ether	-	mg/kg	5	ND	ND	ND
Tetrabromodiphenyl ether	-	mg/kg	5	ND	ND	ND
Pentabromodiphenyl ether	-	mg/kg	5	ND	ND	ND
Hexabromodiphenyl ether	-	mg/kg	5	ND	ND	ND
Heptabromodiphenyl ether	-	mg/kg	5	ND	ND	ND
Octabromodiphenyl ether	-	mg/kg	5	ND	ND	ND
Nonabromodiphenyl ether	-	mg/kg	5	ND	ND	ND
Decabromodiphenyl ether	-	mg/kg	5	ND	ND	ND
Dibutyl Phthalate (DBP)	1000	mg/kg	50			ND
Butyl benzyl Phthalate (BBP)	1000	mg/kg	50			ND
Bis (2-ethylhexyl) Phthalate (DEHP)	1000	mg/kg	50			ND
Diisobutyl Phthalates (DIBP)	1000	mg/kg	50			ND

Test Item(s)	Limit	Unit	MDL	007	008
Cadmium (Cd)	100	mg/kg	2	ND	ND
Lead (Pb)	1,000	mg/kg	2	ND	ND
Mercury (Hg)	1,000	mg/kg	2	ND	ND
Hexavalent Chromium (CrVI)	1,000	mg/kg	2	ND	ND
Sum of PBBs	1,000	mg/kg	-	ND	ND
Monobromobiphenyl	-	mg/kg	5	ND	ND
Dibromobiphenyl	-	mg/kg	5	ND	ND
Tribromobiphenyl	-	mg/kg	5	ND	ND
Tetrabromobiphenyl	-	mg/kg	5	ND	ND
Pentabromobiphenyl	-	mg/kg	5	ND	ND
Hexabromobiphenyl	-	mg/kg	5	ND	ND
Heptabromobiphenyl	-	mg/kg	5	ND	ND
Octabromobiphenyl	-	mg/kg	5	ND	ND
Nonabromobiphenyl	-	mg/kg	5	ND	ND
Decabromobiphenyl	-	mg/kg	5	ND	ND

Unless otherwise agreed in writing, this document is issued by the Company subject to its General Conditions of Service printed overleaf, available on request or accessible at <http://www.sgs.com/en/Terms-and-Conditions.aspx> and, for electronic format documents, subject to Terms and Conditions for Electronic Documents at <http://www.sgs.com/en/Terms-and-Conditions/Terms-e-Documents.aspx>. Attention is drawn to the limitation of liability, indemnification and jurisdiction issues defined therein. Any holder of this document is advised that information contained hereon reflects the Company's findings at the time of its intervention only and within the limits of Client's instructions, if any. The Company's sole responsibility is to its Client and this document does not exonerate parties to a transaction from exercising all their rights and obligations under the transaction documents. This document cannot be reproduced except in full, without prior written approval of the Company. Any unauthorized alteration, forgery or falsification of the content or appearance of this document is unlawful and offenders may be prosecuted to the fullest extent of the law. Unless otherwise stated the results shown in this test report refer only to the sample(s) tested.

Attention: To check the authenticity of testing / inspection report & certificate, please contact us at telephone: (86-755) 8307 1443, or email: CN.Doccheck@sgs.com



# Test Report

No. SZXEC1700253401

Date: 10 Apr 2017

Page 4 of 13

Test Item(s)	Limit	Unit	MDL	007	008
Sum of PBDEs	1,000	mg/kg	-	ND	ND
Monobromodiphenyl ether	-	mg/kg	5	ND	ND
Dibromodiphenyl ether	-	mg/kg	5	ND	ND
Tribromodiphenyl ether	-	mg/kg	5	ND	ND
Tetrabromodiphenyl ether	-	mg/kg	5	ND	ND
Pentabromodiphenyl ether	-	mg/kg	5	ND	ND
Hexabromodiphenyl ether	-	mg/kg	5	ND	ND
Heptabromodiphenyl ether	-	mg/kg	5	ND	ND
Octabromodiphenyl ether	-	mg/kg	5	ND	ND
Nonabromodiphenyl ether	-	mg/kg	5	ND	ND
Decabromodiphenyl ether	-	mg/kg	5	ND	ND
Dibutyl Phthalate (DBP)	1000	mg/kg	50	ND	
Butyl benzyl Phthalate (BBP)	1000	mg/kg	50	ND	
Bis (2-ethylhexyl) Phthalate (DEHP)	1000	mg/kg	50	ND	
Diisobutyl Phthalates (DIBP)	1000	mg/kg	50	ND	

Notes :

- (1) The maximum permissible limit is quoted from RoHS Directive (EU) 2015/863.
- (2) On 4 June 2015, Commission Directive (EU) 2015/863 was published in the Official Journal of the European Union (OJEU) to include the phthalates BBP, DBP, DEHP and DIBP into ANNEX II of the Rohs Recast Directive. The new law restricts each phthalate to no more than 0.1% in each homogeneous material of an electrical product.
- (3) The restriction of DEHP, BBP, DBP and DIBP shall apply to medical devices, including in vitro medical devices, and monitoring and control instruments, including industrial monitoring and control instruments, from 22 July 2021.
- (4) The restriction of DEHP, BBP, DBP and DIBP shall not apply to cables or spare parts for the repair, the reuse, the updating of functionalities or upgrading of capacity of EEE placed on the market before 22 July 2019, and of medical devices, including in vitro medical devices, and monitoring and control instruments, including industrial monitoring and control instruments, placed on the market before 22 July 2021.
- (5) The restriction of DEHP, BBP and DBP shall not apply to toys which are already subject to the restriction of DEHP, BBP and DBP through entry 51 of Annex XVII to Regulation (EC) No 1907/2006.'

**RoHS Directive (EU) 2015/863 amending Annex II to Directive 2011/65/EU**

- Test Method :
- (1)With reference to IEC 62321-5:2013, determination of Cadmium by ICP-OES.
  - (2)With reference to IEC 62321-5:2013, determination of Lead by ICP-OES.
  - (3)With reference to IEC 62321-4:2013, determination of Mercury by ICP-OES.
  - (4)With reference to IEC 62321-7-1:2015 , determination of Hexavalent Chromium by Colorimetric Method using UV-Vis.



Unless otherwise agreed in writing, this document is issued by the Company subject to its General Conditions of Service printed overleaf, available on request or accessible at <http://www.sgs.com/en/Terms-and-Conditions.aspx> and, for electronic format documents, subject to Terms and Conditions for Electronic Documents at <http://www.sgs.com/en/Terms-and-Conditions/Terms-e-Documents.aspx>. Attention is drawn to the limitation of liability, indemnification and jurisdiction issues defined therein. Any holder of this document is advised that information contained hereon reflects the Company's findings at the time of its intervention only and within the limits of Client's instructions, if any. The Company's sole responsibility is to its Client and this document does not exonerate parties to a transaction from exercising all their rights and obligations under the transaction documents. This document cannot be reproduced except in full, without prior written approval of the Company. Any unauthorized alteration, forgery or falsification of the content or appearance of this document is unlawful and offenders may be prosecuted to the fullest extent of the law. Unless otherwise stated the results shown in this test report refer only to the sample(s) tested.

Attention: To check the authenticity of testing / inspection report & certificate, please contact us at telephone: (86-755) 8307 1443, or email: CN.Doccheck@sgs.com

# Test Report

No. SZXEC1700253401

Date: 10 Apr 2017

Page 5 of 13

Test Item(s)	Limit	Unit	MDL	003	004	005
Cadmium (Cd)	100	mg/kg	2	ND	ND	ND
Lead (Pb)	1,000	mg/kg	2	ND	ND	ND
Mercury (Hg)	1,000	mg/kg	2	ND	ND	ND
Hexavalent Chromium (Cr(VI))▼	-	µg/cm <sup>2</sup>	0.10	ND	ND	ND

Test Item(s)	Limit	Unit	MDL	009
Cadmium (Cd)	100	mg/kg	2	ND
Lead (Pb)	1,000	mg/kg	2	ND
Mercury (Hg)	1,000	mg/kg	2	ND
Hexavalent Chromium (Cr(VI))▼	-	µg/cm <sup>2</sup>	0.10	ND

Notes :

- (1) The maximum permissible limit is quoted from RoHS Directive (EU) 2015/863.
- (2) ▼= a. The sample is positive for CrVI if the CrVI concentration is greater than 0.13 µg/cm<sup>2</sup>. The sample coating is considered to contain CrVI
  - b. The sample is negative for CrVI if CrVI is ND (concentration less than 0.10 µg/cm<sup>2</sup>). The coating is considered a non-CrVI based coating
  - c. The result between 0.10 µg/cm<sup>2</sup> and 0.13 µg/cm<sup>2</sup> is considered to be inconclusive - unavoidable coating variations may influence the determination

Information on storage conditions and production date of the tested sample is unavailable and thus Cr(VI) results represent status of the sample at the time of testing.

IEC 62321 series is equivalent to EN 62321 series

[http://www.cenelec.eu/dyn/www/f?p=104:30:1742232870351101:::FSP\\_ORG\\_ID,FSP\\_LANG\\_ID:1258637,25](http://www.cenelec.eu/dyn/www/f?p=104:30:1742232870351101:::FSP_ORG_ID,FSP_LANG_ID:1258637,25)

## Halogen

Test Method : With reference to EN 14582:2016, analysis was performed by Ion Chromatograph (IC).

Test Item(s)	Unit	MDL	006	007
Fluorine (F)	mg/kg	50	215	ND
Chlorine (Cl)	mg/kg	50	111	ND
Bromine (Br)	mg/kg	50	ND	ND
Iodine (I)	mg/kg	50	ND	ND

Remark: The result(s) of 001 shown is/are of the total weight of wet sample.



Unless otherwise agreed in writing, this document is issued by the Company subject to its General Conditions of Service printed overleaf, available on request or accessible at <http://www.sgs.com/en/Terms-and-Conditions.aspx> and, for electronic format documents, subject to Terms and Conditions for Electronic Documents at <http://www.sgs.com/en/Terms-and-Conditions/Terms-e-Documents.aspx>. Attention is drawn to the limitation of liability, indemnification and jurisdiction issues defined therein. Any holder of this document is advised that information contained hereon reflects the Company's findings at the time of its intervention only and within the limits of Client's instructions, if any. The Company's sole responsibility is to its Client and this document does not exonerate parties to a transaction from exercising all their rights and obligations under the transaction documents. This document cannot be reproduced except in full, without prior written approval of the Company. Any unauthorized alteration, forgery or falsification of the content or appearance of this document is unlawful and offenders may be prosecuted to the fullest extent of the law. Unless otherwise stated the results shown in this test report refer only to the sample(s) tested.

Attention: To check the authenticity of testing / inspection report & certificate, please contact us at telephone: (86-755) 8307 1443, or email: CN.Doccheck@sgs.com

SGS Bldg, No.3, Jianghao Industrial Park, No.430, Jihua Road, Banliao, Longgang District, Shenzhen, China 518129 t (86-755) 25328888 f (86-755) 83106190 www.sgs.com.cn  
中国·深圳·龙岗区坂田吉华路430号江灏工业园3栋SGS大楼 邮编: 518129 t (86-755) 25328888 f (86-755) 83106190 e sgs.china@sgs.com

ATTACHMENTS

**Pb/Cd/Hg/Cr<sup>6+</sup>/PBBs/PBDEs Testing Flow Chart**

- 1) Name of the person who made testing: Winsen Deng / David Mai / Truly Ren
- 2) Name of the person in charge of testing: Zoe Luo / Laurel Li / Muky Tong /
- 3) These samples were dissolved totally by pre-conditioning method according to below flow chart (Cr<sup>6+</sup> and PBBs/PBDEs test method excluded).

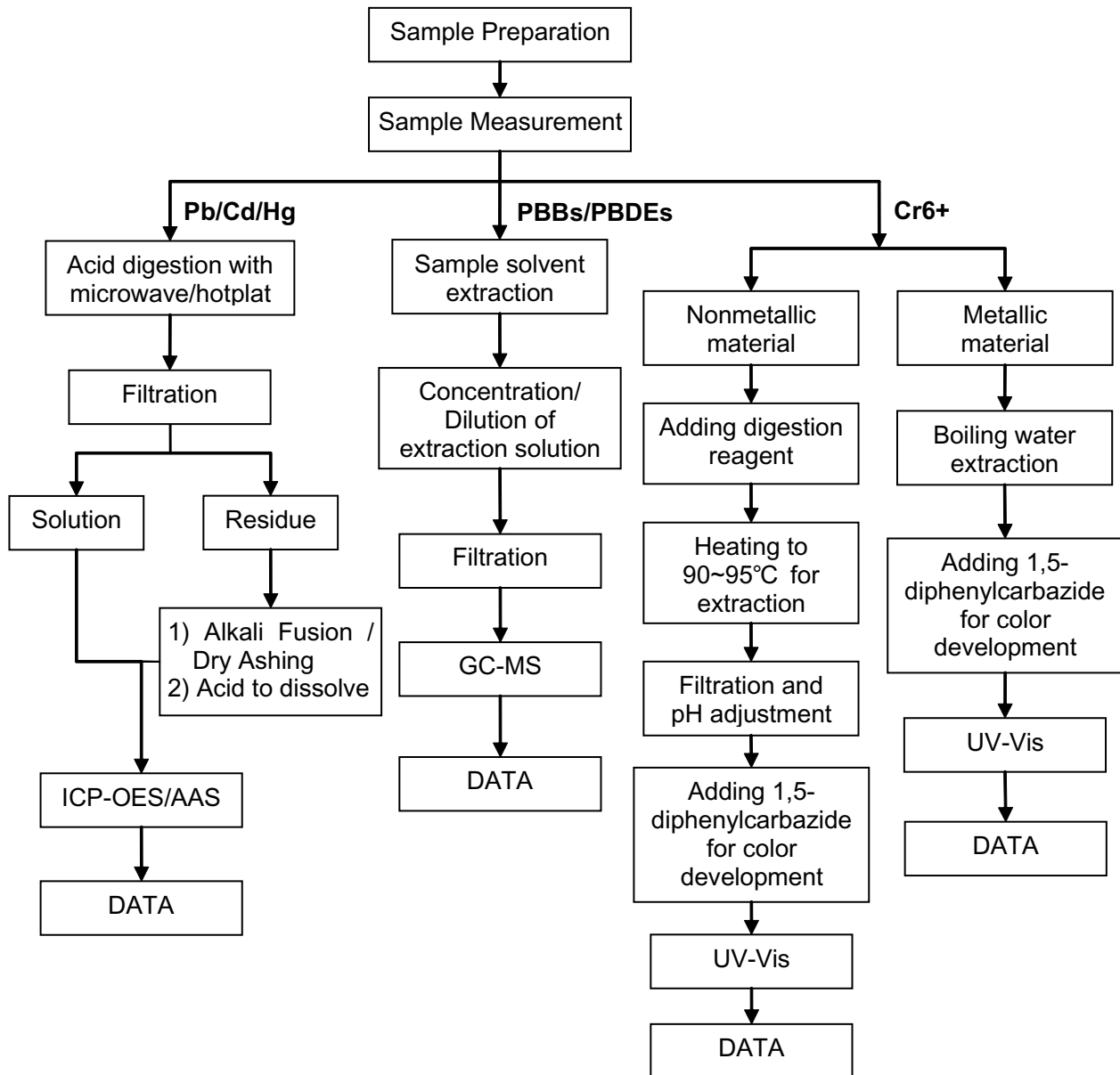

Unless otherwise agreed in writing, this document is issued by the Company subject to its General Conditions of Service printed overleaf, available on request or accessible at <http://www.sgs.com/en/Terms-and-Conditions.aspx> and, for electronic format documents, subject to Terms and Conditions for Electronic Documents at <http://www.sgs.com/en/Terms-and-Conditions/Terms-e-Documents.aspx>. Attention is drawn to the limitation of liability, indemnification and jurisdiction issues defined therein. Any holder of this document is advised that information contained hereon reflects the Company's findings at the time of its intervention only and within the limits of Client's instructions, if any. The Company's sole responsibility is to its Client and this document does not exonerate parties to a transaction from exercising all their rights and obligations under the transaction documents. This document cannot be reproduced except in full, without prior written approval of the Company. Any unauthorized alteration, forgery or falsification of the content or appearance of this document is unlawful and offenders may be prosecuted to the fullest extent of the law. Unless otherwise stated the results shown in this test report refer only to the sample(s) tested.

Attention: To check the authenticity of testing / inspection report & certificate, please contact us at telephone: (86-755) 8307 1443, or email: CN.Doccheck@sgs.com

SGS Bldg, No.3, Jianghao Industrial Park, No.430, Jihua Road, Banlan, Longgang District, Shenzhen, China 518129 t (86-755) 25328888 f (86-755) 83106190 www.sgsgroup.com.cn  
中国·深圳·龙岗区坂田吉华路430号江灏工业园3栋SGS大楼 邮编: 518129 t (86-755) 25328888 f (86-755) 83106190 e sgs.china@sgs.com

ATTACHMENTS

Phthalates Testing Flow Chart

- 1) Name of the person who made testing: David Mai
- 2) Name of the person in charge of testing: Laurel Li

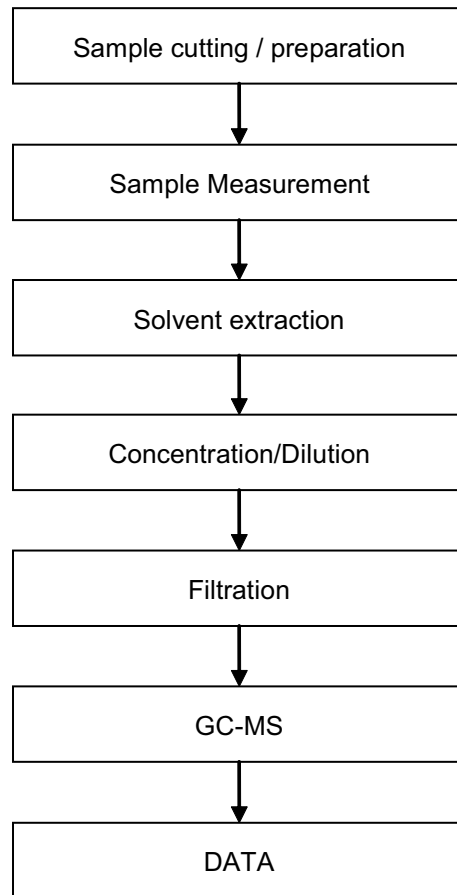

Unless otherwise agreed in writing, this document is issued by the Company subject to its General Conditions of Service printed overleaf, available on request or accessible at <http://www.sgs.com/en/Terms-and-Conditions.aspx> and, for electronic format documents, subject to Terms and Conditions for Electronic Documents at <http://www.sgs.com/en/Terms-and-Conditions/Terms-e-Documents.aspx>. Attention is drawn to the limitation of liability, indemnification and jurisdiction issues defined therein. Any holder of this document is advised that information contained hereon reflects the Company's findings at the time of its intervention only and within the limits of Client's instructions, if any. The Company's sole responsibility is to its Client and this document does not exonerate parties to a transaction from exercising all their rights and obligations under the transaction documents. This document cannot be reproduced except in full, without prior written approval of the Company. Any unauthorized alteration, forgery or falsification of the content or appearance of this document is unlawful and offenders may be prosecuted to the fullest extent of the law. Unless otherwise stated the results shown in this test report refer only to the sample(s) tested.

Attention: To check the authenticity of testing / inspection report & certificate, please contact us at telephone: (86-755) 8307 1443, or email: CN.Doccheck@sgs.com

ATTACHMENTS

Halogen Testing Flow Chart

- 1) Name of the person who made testing: Abel Li
- 2) Name of the person in charge of testing: Roje Zhou

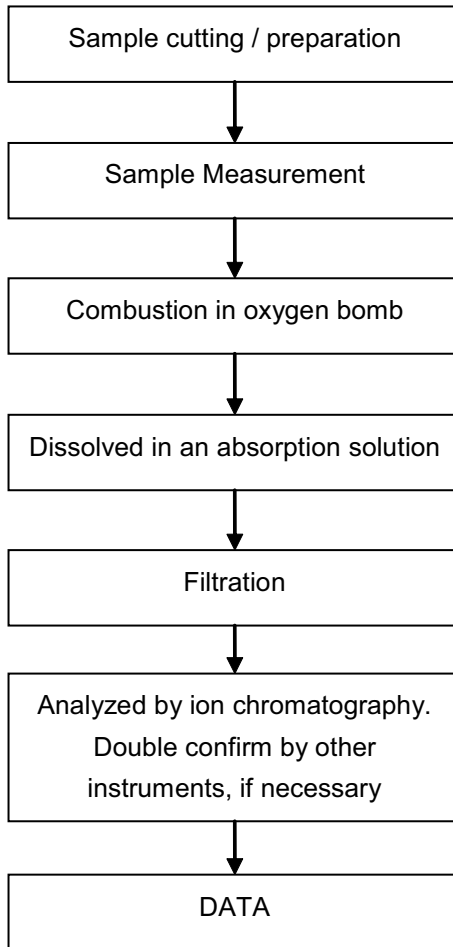

Unless otherwise agreed in writing, this document is issued by the Company subject to its General Conditions of Service printed overleaf, available on request or accessible at <http://www.sgs.com/en/Terms-and-Conditions.aspx> and, for electronic format documents, subject to Terms and Conditions for Electronic Documents at <http://www.sgs.com/en/Terms-and-Conditions/Terms-e-Documents.aspx>. Attention is drawn to the limitation of liability, indemnification and jurisdiction issues defined therein. Any holder of this document is advised that information contained hereon reflects the Company's findings at the time of its intervention only and within the limits of Client's instructions, if any. The Company's sole responsibility is to its Client and this document does not exonerate parties to a transaction from exercising all their rights and obligations under the transaction documents. This document cannot be reproduced except in full, without prior written approval of the Company. Any unauthorized alteration, forgery or falsification of the content or appearance of this document is unlawful and offenders may be prosecuted to the fullest extent of the law. Unless otherwise stated the results shown in this test report refer only to the sample(s) tested.

Attention: To check the authenticity of testing / inspection report & certificate, please contact us at telephone: (86-755) 8307 1443, or email: CN.Doccheck@sgs.com

Sample photo:



Unless otherwise agreed in writing, this document is issued by the Company subject to its General Conditions of Service printed overleaf, available on request or accessible at <http://www.sgs.com/en/Terms-and-Conditions.aspx> and, for electronic format documents, subject to Terms and Conditions for Electronic Documents at <http://www.sgs.com/en/Terms-and-Conditions/Terms-e-Documents.aspx>. Attention is drawn to the limitation of liability, indemnification and jurisdiction issues defined therein. Any holder of this document is advised that information contained hereon reflects the Company's findings at the time of its intervention only and within the limits of Client's instructions, if any. The Company's sole responsibility is to its Client and this document does not exonerate parties to a transaction from exercising all their rights and obligations under the transaction documents. This document cannot be reproduced except in full, without prior written approval of the Company. Any unauthorized alteration, forgery or falsification of the content or appearance of this document is unlawful and offenders may be prosecuted to the fullest extent of the law. Unless otherwise stated the results shown in this test report refer only to the sample(s) tested.

Attention: To check the authenticity of testing / inspection report & certificate, please contact us at telephone: (86-755) 8307 1443, or email: CN.Doccheck@sgs.com

SGS-CSTC (Shenzhen) Technical Services Co., Ltd.  
Shenzhen Branch Testing Center Chemical Laboratory

SGS Bldg, No.3, Jiangheo Industrial Park, No.430, Jihua Road, Banlian, Longgang District, Shenzhen, China 518129 t (86-755) 25328888 f (86-755) 83106190 www.sgs.com  
中国·深圳·龙岗区坂田吉华路430号江源工业园3栋SGS大楼 邮编: 518129 t (86-755) 25328888 f (86-755) 83106190 e sgs.china@sgs.com

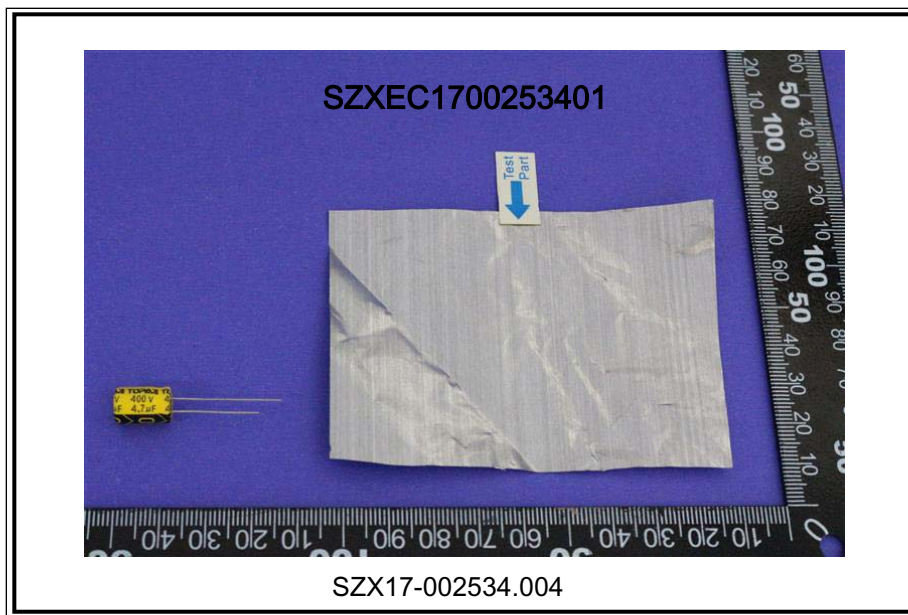
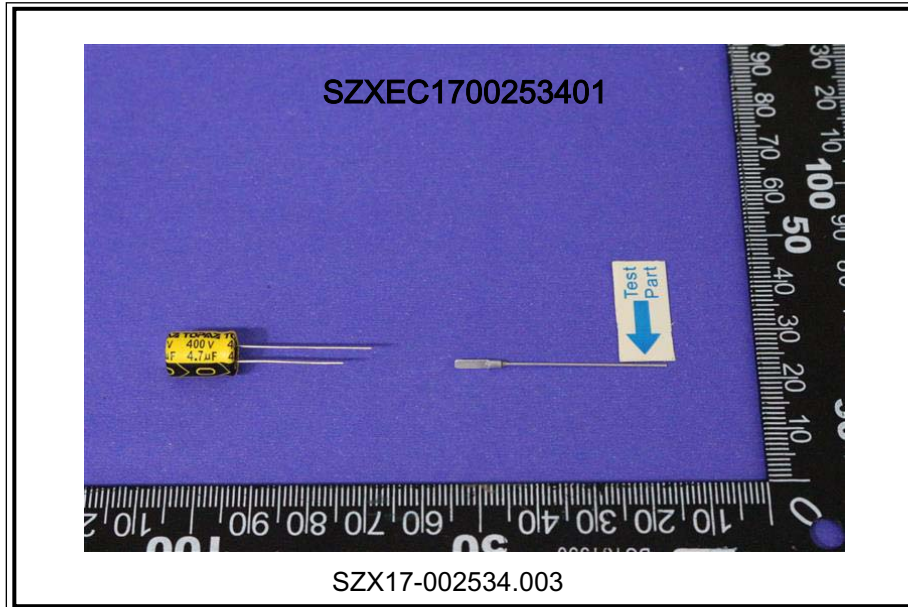

Unless otherwise agreed in writing, this document is issued by the Company subject to its General Conditions of Service printed overleaf, available on request or accessible at <http://www.sgs.com/en/Terms-and-Conditions.aspx> and, for electronic format documents, subject to Terms and Conditions for Electronic Documents at <http://www.sgs.com/en/Terms-and-Conditions/Terms-e-Documents.aspx>. Attention is drawn to the limitation of liability, indemnification and jurisdiction issues defined therein. Any holder of this document is advised that information contained hereon reflects the Company's findings at the time of its intervention only and within the limits of Client's instructions, if any. The Company's sole responsibility is to its Client and this document does not exonerate parties to a transaction from exercising all their rights and obligations under the transaction documents. This document cannot be reproduced except in full, without prior written approval of the Company. Any unauthorized alteration, forgery or falsification of the content or appearance of this document is unlawful and offenders may be prosecuted to the fullest extent of the law. Unless otherwise stated the results shown in this test report refer only to the sample(s) tested.

Attention: To check the authenticity of testing / inspection report & certificate, please contact us at telephone: (86-755) 8307 1443, or email: CN.Doccheck@sgs.com

SGS Bldg, No.3, Jianghao Industrial Park, No.430, Jihua Road, Banliao, Longgang District, Shenzhen, China 518129 t (86-755) 25328888 f (86-755) 83106190 www.sgsgroup.com.cn  
中国·深圳·龙岗区坂田吉华路430号江灏工业园3栋SGS大楼 邮编: 518129 t (86-755) 25328888 f (86-755) 83106190 e sgs.china@sgs.com

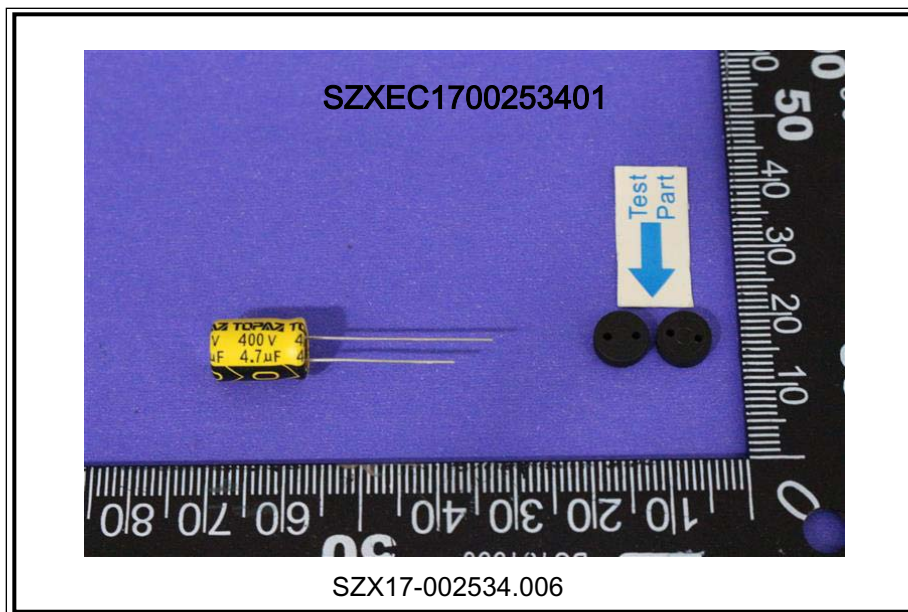
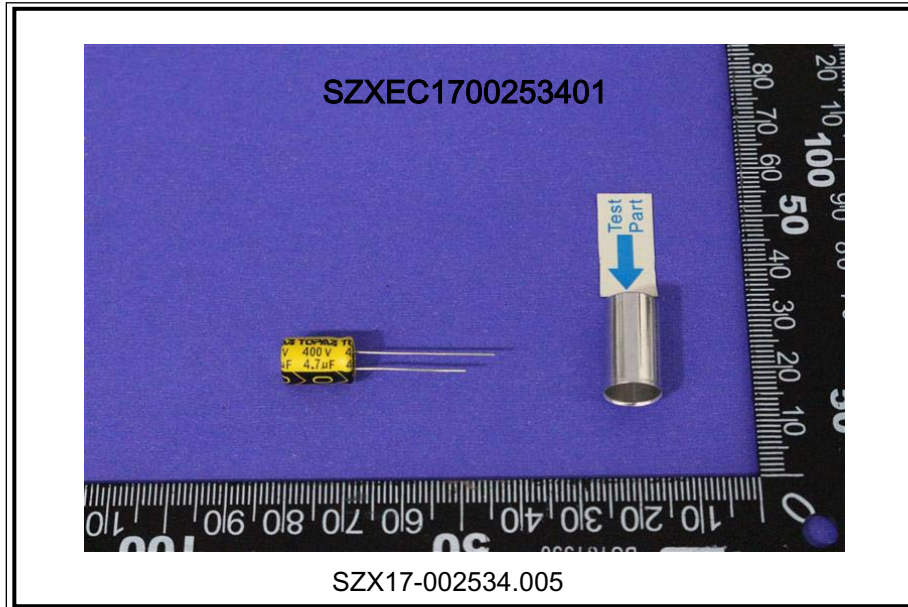

Unless otherwise agreed in writing, this document is issued by the Company subject to its General Conditions of Service printed overleaf, available on request or accessible at <http://www.sgs.com/en/Terms-and-Conditions.aspx> and, for electronic format documents, subject to Terms and Conditions for Electronic Documents at <http://www.sgs.com/en/Terms-and-Conditions/Terms-e-Documents.aspx>. Attention is drawn to the limitation of liability, indemnification and jurisdiction issues defined therein. Any holder of this document is advised that information contained hereon reflects the Company's findings at the time of its intervention only and within the limits of Client's instructions, if any. The Company's sole responsibility is to its Client and this document does not exonerate parties to a transaction from exercising all their rights and obligations under the transaction documents. This document cannot be reproduced except in full, without prior written approval of the Company. Any unauthorized alteration, forgery or falsification of the content or appearance of this document is unlawful and offenders may be prosecuted to the fullest extent of the law. Unless otherwise stated the results shown in this test report refer only to the sample(s) tested.

Attention: To check the authenticity of testing / inspection report & certificate, please contact us at telephone: (86-755) 8307 1443, or email: CN.Doccheck@sgs.com

SGS Bldg, No.3, Jianghao Industrial Park, No.430, Jihua Road, Banlian, Longgang District, Shenzhen, China 518129 t (86-755) 25328888 f (86-755) 83106190 www.sgsgroup.com.cn  
 中国·深圳·龙岗区坂田吉华路430号江灏工业园3栋SGS大楼 邮编: 518129 t (86-755) 25328888 f (86-755) 83106190 e sgs.china@sgs.com



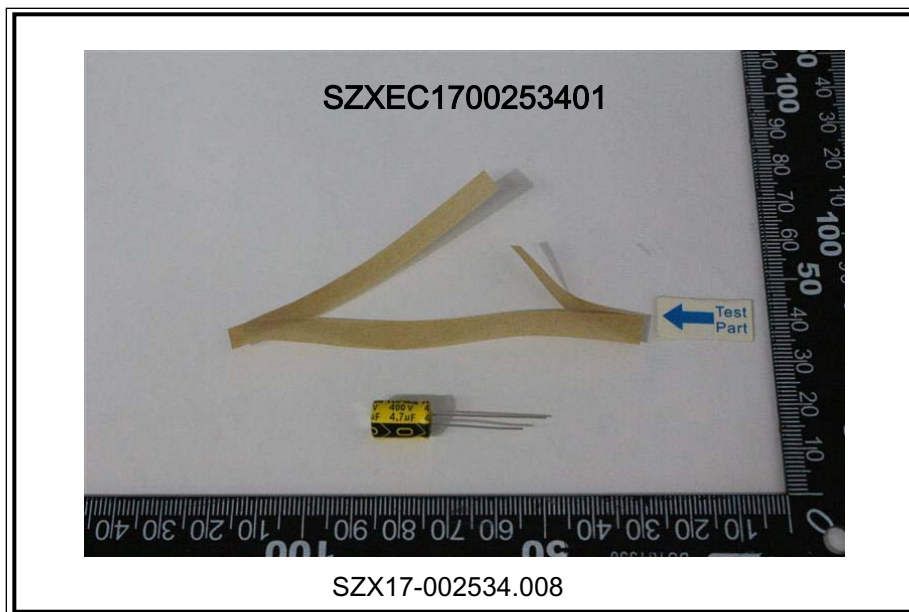
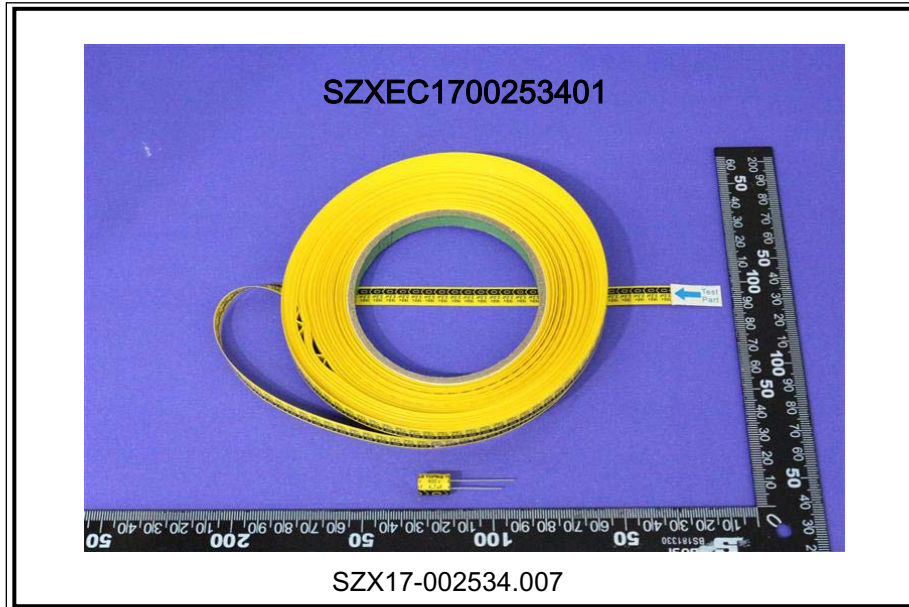

Unless otherwise agreed in writing, this document is issued by the Company subject to its General Conditions of Service printed overleaf, available on request or accessible at <http://www.sgs.com/en/Terms-and-Conditions.aspx> and, for electronic format documents, subject to Terms and Conditions for Electronic Documents at <http://www.sgs.com/en/Terms-and-Conditions/Terms-e-Documents.aspx>. Attention is drawn to the limitation of liability, indemnification and jurisdiction issues defined therein. Any holder of this document is advised that information contained hereon reflects the Company's findings at the time of its intervention only and within the limits of Client's instructions, if any. The Company's sole responsibility is to its Client and this document does not exonerate parties to a transaction from exercising all their rights and obligations under the transaction documents. This document cannot be reproduced except in full, without prior written approval of the Company. Any unauthorized alteration, forgery or falsification of the content or appearance of this document is unlawful and offenders may be prosecuted to the fullest extent of the law. Unless otherwise stated the results shown in this test report refer only to the sample(s) tested.

Attention: To check the authenticity of testing / inspection report & certificate, please contact us at telephone: (86-755) 8307 1443, or email: CN.Doccheck@sgs.com

SGS Bldg, No.3, Jianghao Industrial Park, No.430, Jihua Road, Banlan, Longgang District, Shenzhen, China 518129 t (86-755) 25328888 f (86-755) 83106190 www.sgs.com.cn  
 中国·深圳·龙岗区坂田吉华路430号江灏工业园3栋SGS大楼 邮编: 518129 t (86-755) 25328888 f (86-755) 83106190 e sgs.china@sgs.com

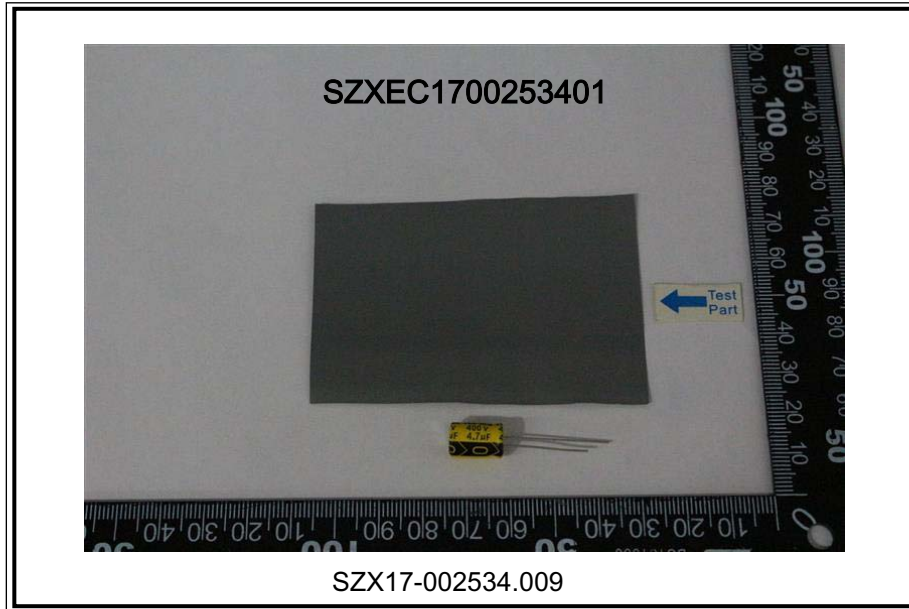

SGS authenticate the photo on original report only

\*\*\* End of Report \*\*\*



Unless otherwise agreed in writing, this document is issued by the Company subject to its General Conditions of Service printed overleaf, available on request or accessible at <http://www.sgs.com/en/Terms-and-Conditions.aspx> and, for electronic format documents, subject to Terms and Conditions for Electronic Documents at <http://www.sgs.com/en/Terms-and-Conditions/Terms-e-Documents.aspx>. Attention is drawn to the limitation of liability, indemnification and jurisdiction issues defined therein. Any holder of this document is advised that information contained hereon reflects the Company's findings at the time of its intervention only and within the limits of Client's instructions, if any. The Company's sole responsibility is to its Client and this document does not exonerate parties to a transaction from exercising all their rights and obligations under the transaction documents. This document cannot be reproduced except in full, without prior written approval of the Company. Any unauthorized alteration, forgery or falsification of the content or appearance of this document is unlawful and offenders may be prosecuted to the fullest extent of the law. Unless otherwise stated the results shown in this test report refer only to the sample(s) tested.

Attention: To check the authenticity of testing / inspection report & certificate, please contact us at telephone: (86-755) 8307 1443, or email: CN.Doccheck@sgs.com