

承認書

SPECIFICATION

Customer : _____

Part Name: _____ **E-CAP** _____

SPEC : _____ **SS Series** _____

Part NO. : _____ **ALL** _____

Date : _____ **2018-3-3** _____

CUSTOMER SIGN	
TOPAZCON	
DRAWING	RATIFY
黃峰	陳慶

SS Series



- Low profile with 5mm height
- Wide temperature range of -40 °C +105 °C
- Endurance:+105 °C 1,000hours
- RoHS Compliant

● **SPECIFICATIONS**

Items	Characteristics						
Category	-40 to +105 °C						
Temperature Range	-40 to +105 °C						
Rated Voltage Range	6.3 to 50Vdc						
Capacitance Tolerance	± 20%/M (at 20 °C , 120Hz)						
Leakage Current	I ≤ 0.01CV or 3µA whichever is greater Where, I:Max leakage current;A;C:Nominal capacitance (µF) V:Rated voltage(V) (at 20 °C , after 2minutes)						
Dissipation Factor (tanδ)	Rated voltage(Vdc)	6.3	10	16	25	35	50
	Tanδ (Max)	0.28	0.24	0.20	0.14	0.12	0.10
Low Temperature Characteristics (Max impedance Ratio)	Rated voltage(Vdc)	6.3	10	16	25	35	50
	ZI-25 °C /ZI+20 °C ZI-40 °C /ZI+20 °C	3		2		3	
Endurance	The following specifications shall be satisfied when the capacitors are restored to 20 °C after the rated voltage is applied for 1,000 hours at 105 °C						
	Capacitance change	≤ ± 20% of the initial value					
	DF (tanδ)	≤ 200% of the initial specified value					
Shelf Life	The following specifications shall be satisfied when the capacitors are restored to 20 °C after exposing them for 500 hours at 105 °C without voltage applied.						
	Capacitance change	≤ ± 20% of the initial value					
	DF (tanδ)	≤ 200% of the specified value					
	Leakage current	≤ The initial specified value					

● **DIMENSIONS[MM]**

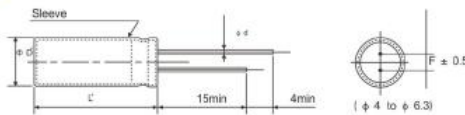

Φ D	4	5	6.3
Φ d	0.45	0.45	0.45
F	1.5	2.0	2.5
Φ D'	Φ D+0.5max		
L'	L+1.5max		

● **RATED RIPPLE CURRENT MULTIPLIERS**

Frequency correction factor for ripple current

WV(Vdc) \ Freq (Hz)	50/60	120	1k	10k-100k
6.3 to 16	0.80	1.00	1.30	1.50
25 to 35	0.80	1.00	1.20	1.20
50	0.80	1.00	1.15	1.20

The endurance of capacitors is shorted with internal heating produced by ripple current at the rate of halving the lifetime with every 5 °C rise. When long life performance is required in actual use, the rms ripple current has to be reduced

SS Series

● STANDARD RATINGS

WV(Vs)	Cap(μ F)	Case size φ Dia(Lmm)	Tanδ	Ripple current (mA rms/105 °C, 120Hz)
6.3(DJ)	22	4 × 5	0.28	23
	33	5 × 5	0.28	30
	47	5 × 5	0.28	37
	100	6.3 × 5	0.28	57
10(IA)	10	4 × 5	0.24	20
	22	5 × 5	0.24	28
	33	5 × 5	0.24	34
	47	6.3 × 5	0.24	52
16(1C)	4.7	4 × 5	0.20	15
	10	4 × 5	0.20	23
	22	5 × 5	0.20	31
	33	6.3 × 5	0.20	48
25(1E)	4.7	4 × 5	0.14	15
	10	5 ×	0.14	22

WV(Vs)	Cap(μ F)	Case size φ Dia(Lmm)	Tanδ	Ripple current (mA rms/105 °C, 120Hz)
25(1E)	22	6.3 × 5	0.14	44
	33	6.3 × 5	0.14	48
35(1V)	3.3	4 × 5	0.12	13
	4.7	4 × 5	0.12	17
	10	5 × 5	0.12	24
50(1H)	22	6.3 × 5	0.12	48
	0.1	4 × 5	0.10	1
	0.22	4 × 5	0.10	2
	0.33	4 × 5	0.10	3
50(1H)	0.47	4 × 5	0.10	4
	1	4 × 5	0.10	8
	2.2	4 × 5	0.10	13
	3.3	4 × 5	0.10	14
	4.7	5 × 5	0.10	18
	10	6.3 × 5	0.10	28

SS Series

- Low profile with 7mm height
- Endurance: +105 °C 2,000hours
- Wide temperature range of -40 °C +105 °C
- RoHS Compliant



SPECIFICATIONS

Items	Characteristics								
Category	-40to+105 °C								
Temperature Range	6.3to 63vdc								
Rated Voltage Range	± 20%(M)								
Capacitance Tolerance	(at20 °C ,120Hz)								
Leakage Current	I ≤ 0.01CV or 3uA whichever is greater Where, I Max leakage current(uA),C,Nominal capacitance (uF) V,Rated voltage(V) (at 20 °C after 2minutes)								
Dissipation Factor (tanδ)	Rated voltage(Vdc)	6.3	10	16	25	35	50	63	
	Tanδ (Max)	0.22	0.19	0.16	0.14	0.12	0.10	0.09	
Low Temperature Characteristics (Max.Impedance Ratio)	Rated voltage(Vdc)	6.3	10	16	25	35	50	63	
	Z[-25 °C]/Z[+20 °C]	4	3	2					
Endurance	Z[-40 °C]/Z[+20 °C]	8	5	4	3				
	The following specifications shall be satisfied when the capacitors are restored to 20 °C after the rated voltage is applied for 2,000 hours at 105 °C								
Shelf Life	Capacitance change	≤ ± 20% of the initial value							
	DF (tanδ)	≤ 200% of the initial specified value							
	Leakage current	≤ The initial specified value							
Shelf Life	The following specifications shall be satisfied when the capacitor are restored to 20 °C after exposing them for 1,000hours at 105 °C without voltage applied.								
	Capacitance change	≤ ± 20% of the initial value							
	DF (tanδ)	≤ 200% of the specified value							
Shelf Life	The following specifications shall be satisfied when the capacitor are restored to 20 °C after exposing them for 1,000hours at 105 °C without voltage applied.								
	Capacitance change	≤ ± 20% of the initial value							
	DF (tanδ)	≤ 200% of the specified value							
Shelf Life	The following specifications shall be satisfied when the capacitor are restored to 20 °C after exposing them for 1,000hours at 105 °C without voltage applied.								
	Capacitance change	≤ ± 20% of the initial value							
	DF (tanδ)	≤ 200% of the specified value							

DIMENSIONS[MM]

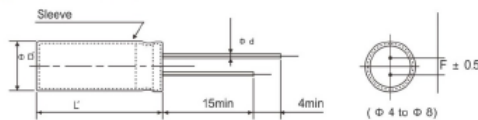

Φ D	4	5	6.3	8
Φ d	0.45	0.45	0.5	0.5
F	1.5	2.0	2.5	3.5
Φ D'	Φ D+0.5max			
L'	L+2max			

RATED RIPPLE CURRENT MULTIPLIERS
 Frequency correction factor for ripple current

Freq (Hz)	50/60	120	1k	10k-100k
6.3 to 16	0.80	1.00	1.30	1.50
25 to 35	0.80	1.00	1.20	1.20
≥ 50	0.80	1.00	1.15	1.20

The endurance of capacitors is shorted with internal heating produced by ripple current at the rate of halving the lifetime with every 5 °C rise. When long life performance is required in actual use, the rms ripple current has to be reduced

SS Series

● STANDARD RATINGS

WV(%)	Cap (μF)	Case size φ DxD(Lmm)	Tanδ	Ripple current (mA _{rms} /105℃, 120Hz)
6.3(0.1)	22	4 × 7	0.22	28
	33	4 × 7	0.22	32
		5 × 7	0.22	35
	47	5 × 7	0.22	47
	68	5 × 7	0.22	50
	100	6.3 × 7	0.22	75
	220	8 × 7	0.22	92
10(1A)	22	4 × 7	0.19	32
	33	5 × 7	0.19	60
	47	5 × 7	0.19	51
	68	6.3 × 7	0.19	68
	100	6.3 × 7	0.19	80
		8 × 7	0.19	95
220	8 × 7	0.19	130	
16(1C)	10	4 × 7	0.16	28
	22	4 × 7	0.16	35
		5 × 7	0.16	42
	33	5 × 7	0.16	50
	47	6.3 × 7	0.16	67
	68	6.3 × 7	0.16	70
		8 × 7	0.16	78
	100	8 × 7	0.16	110
25(1E)	4.7	4 × 7	0.14	17
	6.8	4 × 7	0.14	19
	10	4 × 7	0.14	28
		5 × 7	0.14	33
	22	5 × 7	0.14	43
		6.3 × 7	0.14	45
	33	6.3 × 7	0.14	62
	47	8 × 7	0.14	75
	68	8 × 7	0.14	80
	100	8 × 7	0.14	115
35(1V)	4.7	4 × 7	0.12	22
	6.8	4 × 7	0.12	24
		5 × 7	0.12	28
	10	5 × 7	0.12	35
	22	6.3 × 7	0.12	60
	33	6.3 × 7	0.12	50
		8 × 7	0.12	68
	47	8 × 7	0.12	80
	68	8 × 7	0.12	85
	50(1H)	0.1	4 × 7	0.10
0.22		4 × 7	0.10	2.5
0.33		4 × 7	0.10	3.5
0.47		4 × 7	0.10	5
0.68		4 × 7	0.10	7
1		4 × 7	0.10	10
2.2		4 × 7	0.10	20
3.3		4 × 7	0.10	26
4.7		4 × 7	0.10	27
		5 × 7	0.10	29
10	6.3 × 7	0.10	38	
22	8 × 7	0.10	63	
33	8 × 7	0.10	78	
63(1J)	0.1	4 × 7	0.09	1.5
	0.22	4 × 7	0.09	2.5
	0.33	4 × 7	0.09	3.5
	0.47	4 × 7	0.09	6
	1	4 × 7	0.09	12
	2.2	4 × 7	0.09	20
	3.3	5 × 7	0.09	28
	4.7	6.3 × 7	0.09	33
	10	6.3 × 7	0.09	40
	22	8 × 7	0.09	65

Lead Forming

Taping Specifications

Fig.1 Code:T1

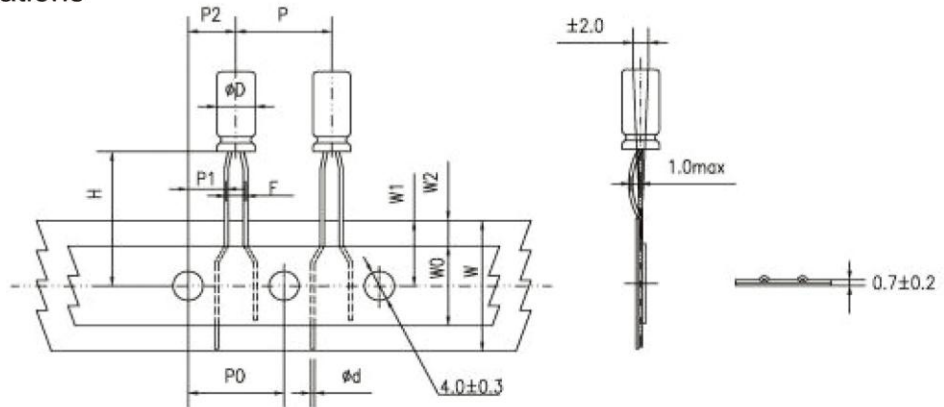

Fig.2 Code:T2

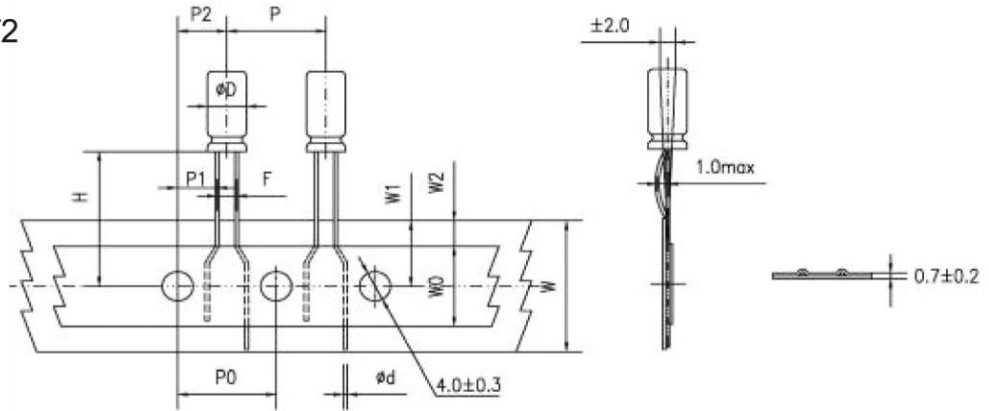

Fig.3 Code:T2

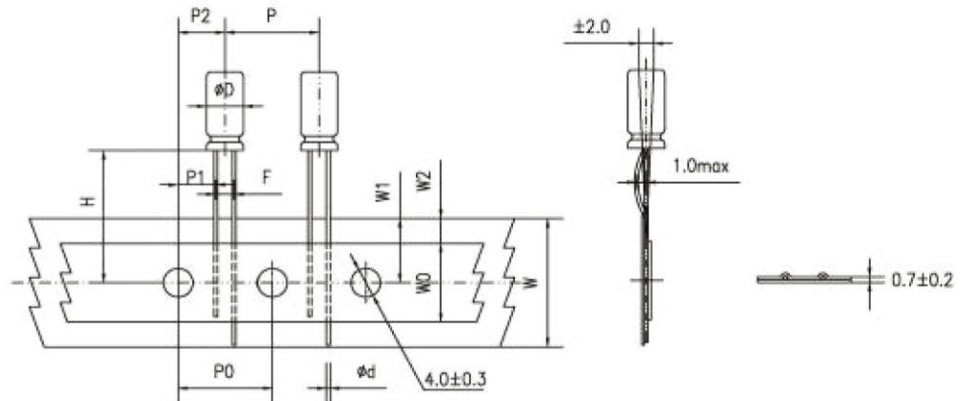
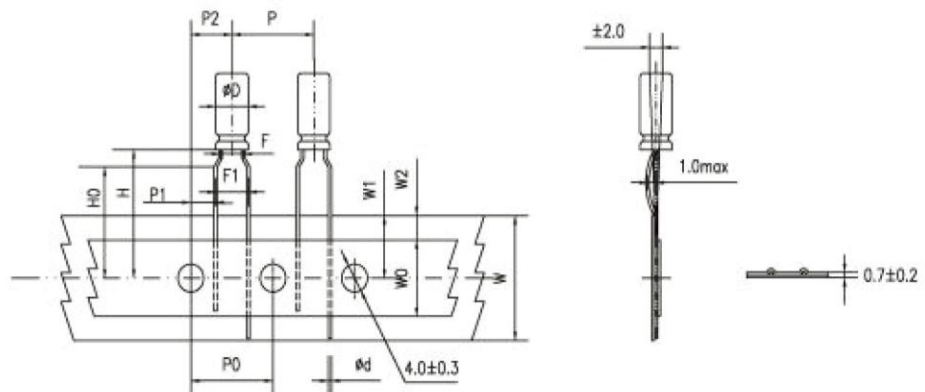

Fig.4 Code:T3



Specification Fig.1 & Fig.2 & Fig.3

Items	Symbol	CASE SIZE										Tolerance		
		4 × 5 4 × 7		5 × 5 5 × 7		5×11		6.3×5	6.3×7 6.3×9	6.3×11 6.3×12	8×5/7 8×9/11 8×11.5 8×12		8×16 8×20	10×9/12 10×12.5 10×13/16 10×20/25
Pin Code		T ₁	T ₂	T ₁	T ₂	T ₁		T ₂	T ₂	T ₂	T ₂	T ₂		
Lead wire diameter	φd	0.45		0.45		0.5		0.45	0.5	0.5	0.45/0.5	0.6	± 0.05	
Pitch of body	P	12.7		12.7		12.7		12.7	12.7	12.7	12.7	12.7	± 1.0	
Feed hole pitch	PO	12.7		12.7		12.7		12.7	12.7	12.7	12.7	12.7	± 0.2	
Hole center to lead distance	P1	5.1	5.6	5.1	5.35	5.1	5.35	5.1	5.1	5.1	4.6	4.6	3.85	± 0.7
Feed hole center to body center distance	P2	6.35		6.35		6.35		6.35	6.35	6.35	6.35	6.35	6.35	± 1.0
Lead to lead distance	F	2.5	1.5	2.5	2.0	2.5	2.0	2.5	2.5	2.5	3.5	3.5	5.0	± 0.5
Height of body from tape center	H	18.5		18.5		18.5		18.5	18.5	18.5	18.5	18.5	18.5	± 0.75
Base tape width	W	18.0		18.0		18.0		18.0	18.0	18.0	18.0	18.0	18.0	± 0.5
Adhesive tape width	WO	11.0		11.0		11.0		11.0	11.0	11.0	11.0	11.0	11.0	min
Hole positron	W1	9.0		9.0		9.0		9.0	9.0	9.0	9.0	9.0	9.0	+0.75 -0.5
Hole down tape position	W2	3.0		3.0		3.0		3.0	3.0	3.0	3.0	3.0	3.0	max

Specification Fig.4

Items	Symbol	CASE SIZE									Tolerance		
		4 × 5 4 × 7	5 × 5	5 × 7	5 × 11	6.3 × 5	6.3 × 7 6.3 × 9	6.3 × 11 6.3 × 12	8 × 5/7 8 × 9/11 8 × 11.5/12	8 × 16 8 × 20			
Pin Code		T ₃	T ₃	T ₃	T ₃	T ₃	T ₃	T ₃	T ₃	T ₃			
Lead wire diameter	φd	0.45		0.45		0.5		0.45	0.5	0.5	0.45/0.5	0.6	± 0.05
Pitch of body	P	12.7		12.7		12.7		12.7	12.7	12.7	12.7	12.7	± 1.0
Feed hole pitch	PO	12.7		12.7		12.7		12.7	12.7	12.7	12.7	12.7	± 0.2
Hole center to lead distance	P1	3.85		3.85		3.85		3.85	3.85	3.85	3.85	3.85	± 0.7
Feed hole center to body center distance	P2	6.35		6.35		6.35		6.35	6.35	6.35	6.35	6.35	± 1.0
Lead to lead distance	F	1.5		2.0		2.0		2.5	2.5	2.5	3.5	3.5	± 0.5
Lead to lead distance	F1	5.0		5.0		5.0		5.0	5.0	5.0	5.0	5.0	+0.8 -0.2
Height of body from tape center	H	18.5		18.5		18.5		18.5	18.5	18.5	18.5	18.5	± 0.75
Lead wire clinch height	HO	16.0		16.0		16.0		16.0	16.0	16.0	16.0	16.0	± 0.5
Base tape width	W	18.0		18.0		18.0		18.0	18.0	18.0	18.0	18.0	± 0.5
Adhesive tape width	WO	11.0		11.0		11.0		11.0	11.0	11.0	11.0	11.0	min
Hole position	W1	9.0		9.0		9.0		9.0	9.0	9.0	9.0	9.0	+0.75 -0.5
Hole down tape position	W2	3.0		3.0		3.0		3.0	3.0	3.0	3.0	3.0	max

● Lead Forming & Cut:

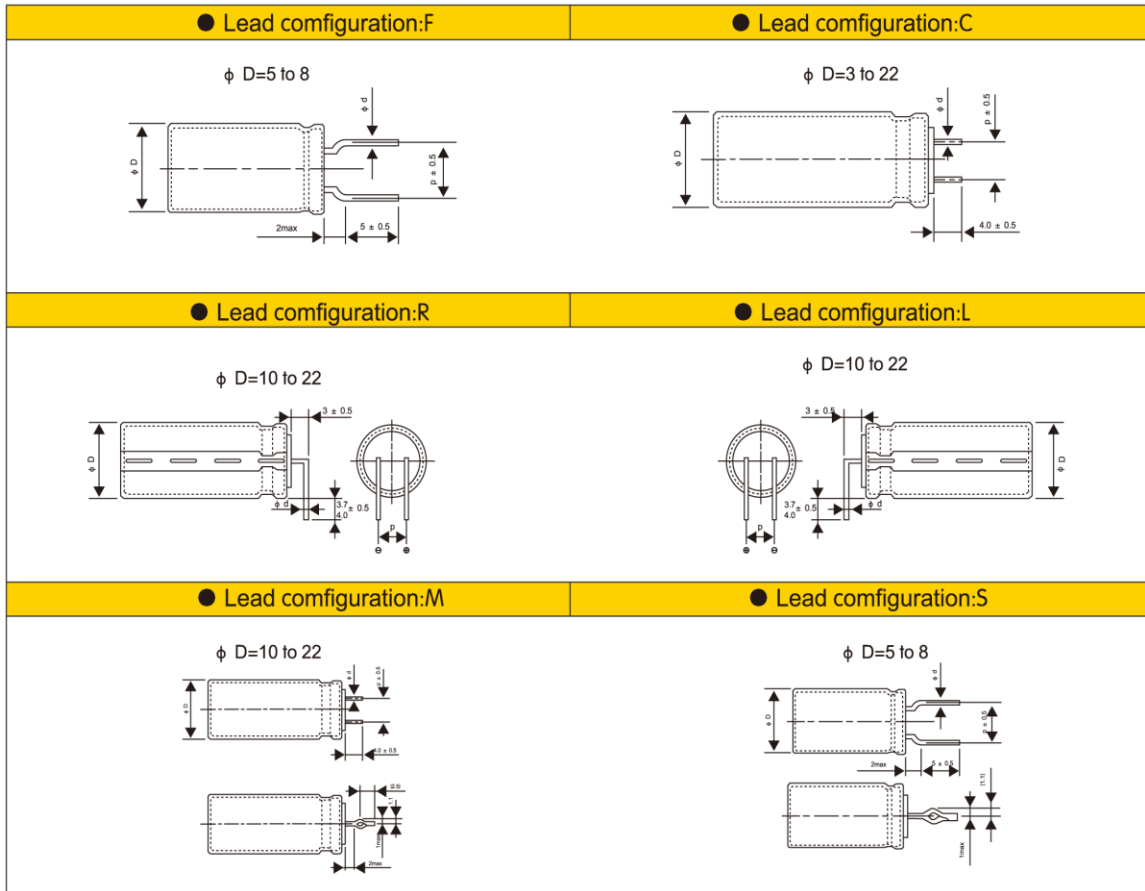

● LEAD SPACING&RECOMMENDED PCB DIMENSIONS

(mm)

Dimension	ϕd	p	PC Board		Lead Configuration
			Hole diameter	Thickness	
5	0.5	5.0	0.8	1.6	F C S
6.3	0.5	5.0	0.8		
8	0.5/0.6	5.0	1.0		
10	0.6	5.0	1.0	1.6	C M R L
12.5	0.6	5.0	1.0		
16	0.8	7.5	1.2		
18	0.8	7.5	1.2		
20	0.8	7.5	1.2		
22	0.8	10.0	1.2		

TEL: 86-769-85391636 / 85391626 FAX: 86-769-85325630

http:www.songshengdg.com E-mail:songshengcw@163.com

廣東省東莞市大朗鎮佛子凹村佛富路三號 郵編：523781

● Lead configuration:B

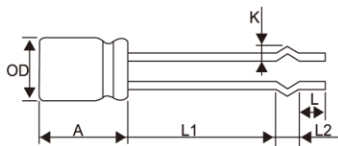

∅D	L1	L2	K	A	L	
5	17.5-19.5	2.6	1.9	10.0-15.0	3.0-5.0	
6.3	17.5-19.5	2.6	1.9	10.0-16.0		
8	12.0-14.0	2.5	1.3	10.0-20.0		
8	13.5-15.5	2.5	1.5			
8	13.0-15.0	3.0	1.5			
8	19.5-21.5	3.0	1.5			
8	21.0-23.0	3.0	1.5			
10	7.5-9.5	2.5	1.7	10.0-25.0		
10	17.0-19.0	2.5	1.7			
10	10.5-12.5	2.5	1.5			
10	10.0-12.0	3.0	1.5			
10	13.0-15.0	3.0	1.5			
10	18.0-20.0	3.0	1.5			
10	21.0-23.0	3.0	1.5			
	± 1.0	± 0.5	0.3	± 1.0		± 1.0

● Lead configuration:K

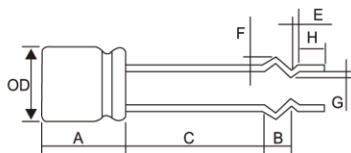

∅D	C	B	E	F	G	A	H
8	13.5-15.5	3	1.2	1.8	0.8	10-20	3.0-5.0
10	18.5-20.5	3	1.2	1.8	1	10-25	
10	19.0-21.0	3	1.5	1.4	0.5		
	± 1.0	± 0.5	± 0.3	± 0.3	± 0.3	± 1.0	± 1.0

鋁電解電容器的使用注意事項

Guidelines For Using Aluminum Electrolytic Capacitor

為使客戶獲得電解電容器的最佳性能和延長電解電容器的使用壽命，在使用電解電容器前，請務必閱讀本注意事項。

Upon using Aluminum Electrolytic Capacitors, please proper handling and observing to following important points will insure optimum capacitor performance and long life.

1、直流電解電容器是有極性的 DC electrolytic capacitors are polarized.

確定極性，極性標誌在電容器的基體上。以免因極性反可能引起電路短路或電容器損壞，當極性不固定或不確定的，使用雙極性電容器。注意直流電解電容器不能使用於交流。

Make sure of the polarity .The polarity is marked on the body of the capacitor .Application of the reversed voltage may cause a short circuit or damage to the capacitor. Use bipolar capacitors when the polarity is not determined or unknown. Note that DC electrolytic capacitors can not be used for AC application.

2、雙極性電容器

Bipolar capacitors

只適用於脈動電路和極性反轉電路中，不適用於純交流和高紋波電路中。

They are used only in pulse circuits as well as polarity reverse circuits. but not applicable in pure AC or high ripple current.

3、使用電壓不要大於額定電壓 DO not apply voltage greater than rated voltage .

使用電壓大於額定電壓，漏電流會增大，可能損壞電容器。建議工作電壓為額定電壓的百分之七十~八十，電容器在建議的工作電壓下使用可延長電容器的壽命。

If a voltage exceeding the rated voltage is applied , the leakage current will increase ,which damage the capacitor. Recommended working voltage is 70 to 80 percent of rated voltage. Using capacitors at recommended working voltage prolongs capacitor life.

4、不要使過量的紋波電流通過電容器

Do not allow excessive ripple current through the capacitor.

流過電容器的紋波電流超過許可值，將會引起電容器發熱，電容量減少，損害電容器。通過電容器的紋波電流不要大於允許值，一般不超過額定值的 80%。

The flow of ripple current over permissible ripple current will cause heat of the capacitor, which may decrease the capacitance and damage the capacitor. ripple current on the capacitor must be at or bellow allowable level, generally not more than 80% of the rated current.

5、快速的充放電電路中，使用專門設計的電容器

Use specially designed capacitors for the circuits where charge and discharge are frequency repeated.

在經受快速的週期性充放電電路中，電容器可能受損害，它的壽命因容量下降、溫升等原因而縮短，在這種電路中，一定要使用專門設計的電容器。

In the circuit subjected to rapid charge and discharge cycles, capacitors may be damaged, its life may be shortened by capacitance decrease, heat rise, ect. Be sure and use special capacitors in these applications.

6、工作溫度範圍 Operating temperature range.

電容器的特性隨工作溫度而變化，在溫度較高的情況下，容量、漏電流增大， $\text{tg } \delta$ 減少；在低溫情況下，容量和漏電流下降， $\text{tg } \delta$ 增大。電容器在較低的溫度下使用會確保延長壽命。

The characteristics of capacitors change with the operating temperature. The capacitance and leakage current increase and $\text{tg } \delta$ decrease at higher temperatures. The capacitance and leakage current decrease and $\text{tg } \delta$ increase at lower temperature. Usage at lower temperature will ensure longer life.

7、使用溫度與壽命的關係 Relationship between temperature and life.

電容器的壽命與其使用的溫度有關，一般來說，使用溫度降低 10°C，其壽命是額定溫度下的 2 倍，計算公式如下：

Life of capacitors has relationship with its used temperature .Generally, if the used temperature is reduced 10°C ,life is prolonged twice at rated temperature. Here is calculating format:

$$LS = LO \times 2^{\frac{T_0 - T_x}{10}} \times 2^{\frac{\Delta T_m - \Delta T_m \left(\frac{I_x}{I_0} \right)^2}{10}}$$

L0: Useful life when applied ripple current Istd at maximal operating temperature T0,H

T0: Maximum Operating Temperature .

Tx: Actual Operating Temperature.

△Tm: 5°C

Ix: Actual Ripple Current

I0: Rated Ripple Current.

8、核對工作頻率 Check operating frequency.

電解電容器的電容量通常是在 100Hz 或 120Hz 下測得的。然而要記住容量隨頻率的升高而下降，tg δ 隨頻率的升高而增大，並使周圍溫度升高。

The capacitance of electrolytic capacitors is usually measured at 100Hz or 120Hz. However , remember that capacitance decrease and tg δ increase as the applied frequency becomes higher whereas the ambient temperature becomes higher.

9、長時間存放的電容器，在使用前加額定直流電壓處理 Apply rated DC voltage treatment to the capacitors which have been stored for a long time.

長時間的存放，實際對電容器的容量和 tg δ 沒有多大的影響，然而往往會使漏電流增大，耐壓降低。

長時間存放後的電容器處理，首先逐漸施加直流電壓至額定電壓，然後再使用。

Long periods of storage have virtually no effect no a capacitor' s capacitance and tg δ. Such periods tend, however, to increase leakage current and decrease withstand voltage.

After removing capacitors from long-duration storage, First apply a gradually increasing DC voltage to rated voltage and then use them.

10、電容器外殼與陰極端是不絕緣的 The capacitor case is not insulated from the cathode terminal.

電容器的外殼與陰極端是通過電解液連接的，如果電容器的外殼必須與線路絕緣，則電容器的安裝位置處，一定要採取絕緣措施。

The capacitor's case and cathode terminal connect through the electrolyte. If the case is to be completely insulated, that insulation must be at the capacitor's mounting point.

11、電容器的端子或引線不要施加過大的力

Do not apply excessive force to the terminals and leads.

過大的力施加到端子或引線上，可能引起引線的斷裂或端子分裂，轉而會引起內部連接的破壞。

The excessive strong force applied to the terminals and lead wires may cause leads to break or terminals to separate and, in turn, cause the internal contact to fail.

12、如電容器需彎腳成臥式狀態。彎腳處應與電容器成體保持 2mm 的安全間距，否則可能造成電容器內部結構損傷。

Such as capacitor to bend feet into horizontal state. Bending feet should maintain with capacitor adult 2mm safe spacing, otherwise may cause the internal of capacitor structural damage

13、浸焊料後，線路板的清洗 Cleaning of the circuit board after solder dipping.

清洗線路板以去除焊劑或其它附著物。爲了保護塑膠套管，印刷標誌以及封口材料不被破壞，電容器不能用鹵化物或類似溶劑作爲電容器清洗用，如三氯乙烯，二甲苯或酮類等。建議使用的清洗溶劑爲：甲醇，異丙醇，乙醇，異丁醇，石油醚，丙醇和一般的洗滌劑。

Cleaning circuit boards to remove flux or other extraneous matter. To ensure protection for sleeve, marking and sealing materials on capacitor body, capacitor should never be washed or cleaned by halogens agents or solvents such as trichlorethylene, xylem or acetone etc. Recommended cleaning solvents. Methanol, isopropanol ethanol, isobutanol, petroleumthe, propane and/or commercial detergents.

14、焊接時注意溫度和持續的時間 Be cautious of the temperature and duration when soldering.

烙鐵應與電容器的塑膠絕緣套管保持一定的距離。當電容器浸于焊料槽時，建議溫度在 260°C 以內，時間不要超過 10 秒鐘，以避免電容器元件受損。

Soldering irons should be kept away from the vinyl insulated sleeves of capacitor. When the capacitor dipped in solder bath, recommendable within 260°C and 10 seconds to avoid damage of capacitor unit.

15、印刷線路板上孔的佈局

Hole positions on the circuit board.

設計印刷線路板時，安裝孔距應等於引線間距，當孔距大於或小於引線間距時，安裝電容器時，將有應力作用到引線上，可能引起短路，電路損壞，漏電流增大。

另外，焊料可能通過所打的孔及後加工零件的引線孔濺落到塑膠套管上，造成損傷，所以要認真考慮孔的佈局。

When designing a circuit board, space the position holes equally to the space between lead wires. When the spacing is either greater than or less than the capacitor's leads, mounting the capacitor will apply to the leads, causing short circuits, broken circuits, and increased current.

Otherwise, through-holes on the circuit board as well as lead holes of post-process parts can result in solder splashing onto the vinyl sleeve, causing damage. Consider hole positions carefully.

Test Report

No. SZXEC1700253401

Date: 10 Apr 2017

Page 1 of 13

GUANGDONG TOPAZ ELECTRONIC TECHNOLOGY CO.,LTD

3 INDUSTRY FACTORY,FU ZI AO VILLAGE FU FU ROAD,DALANG TOWN,DONGGUAN,CHINA
DONGGUAN SONGSHENG ELECTRONICS CO.,LTD.

3 INDUSTRY FACTORY,FU ZI AO VILLAGE FU FU ROAD,DALANG TOWN,DONGGUAN,CHINA

The following sample(s) was/were submitted and identified on behalf of the clients as : Aluminum electrolytic capacitor

SGS Job No. : RP17-002586 - SZ

Date of Sample Received : 31 Mar 2017

Testing Period : 31 Mar 2017 - 06 Apr 2017

Test Requested : Selected test(s) as requested by client.

Test Method : Please refer to next page(s).

Test Results : Please refer to next page(s).

Conclusion : Based on the performed tests on selected part of submitted sample(s), the results of Cadmium, Lead, Mercury, Hexavalent chromium, Polybrominated biphenyls (PBBs), Polybrominated diphenyl ethers (PBDEs) do not exceed the limits as set by RoHS Directive (EU) 2015/863 amending Annex II to Directive 2011/65/EU.

Signed for and on behalf of
SGS-CSTC Standards Technical Services Co., Ltd. Shenzhen Branch



Sunny Nie
Approved Signatory



Unless otherwise agreed in writing, this document is issued by the Company subject to its General Conditions of Service printed overleaf, available on request or accessible at <http://www.sgs.com/en/Terms-and-Conditions.aspx> and, for electronic format documents, subject to Terms and Conditions for Electronic Documents at <http://www.sgs.com/en/Terms-and-Conditions/Terms-e-Documents.aspx>. Attention is drawn to the limitation of liability, indemnification and jurisdiction issues defined therein. Any holder of this document is advised that information contained hereon reflects the Company's findings at the time of its intervention only and within the limits of Client's instructions, if any. The Company's sole responsibility is to its Client and this document does not exonerate parties to a transaction from exercising all their rights and obligations under the transaction documents. This document cannot be reproduced except in full, without prior written approval of the Company. Any unauthorized alteration, forgery or falsification of the content or appearance of this document is unlawful and offenders may be prosecuted to the fullest extent of the law. Unless otherwise stated the results shown in this test report refer only to the sample(s) tested.

Attention: To check the authenticity of testing / inspection report & certificate, please contact us at telephone: (86-755) 8307 1443, or email: CN.Doccheck@sgs.com

SGS-CSTC Standards Technical Services Co., Ltd.
Shenzhen Branch Testing Center-Chemical Laboratory

SGS Bldg, No.3, Jianghao Industrial Park, No.430, Jihua Road, Banliao, Longgang District, Shenzhen, China 518129 t (86-755) 25328888 f (86-755) 83106190 www.sgsgroup.com.cn
中国·深圳·龙岗区坂田吉华路430号江灏工业园3栋SGS大楼 邮编: 518129 t (86-755) 25328888 f (86-755) 83106190 e sgs.china@sgs.com

Test Results :

Test Part Description :

Specimen No.	SGS Sample ID	Description
SN1	SZX17-002534.001	Lt-yellow liquid(semi-product)
SN2	SZX17-002534.002	Transparent adhesive plastic tape(semi-product)
SN3	SZX17-002534.003	Silvery metal pin(semi-product)
SN4	SZX17-002534.004	Grey metal sheet 4#(semi-product)
SN5	SZX17-002534.005	Silvery metal(semi-product)
SN6	SZX17-002534.006	Black plastic(semi-product)
SN7	SZX17-002534.007	Yellow plastic w/ black printing(semi-product)
SN8	SZX17-002534.008	Lt-brown paper(semi-product)
SN9	SZX17-002534.009	Grey metal sheet 9#(semi-product)

Remarks :

- (1) 1 mg/kg = 1 ppm = 0.0001%
- (2) MDL = Method Detection Limit
- (3) ND = Not Detected (< MDL)
- (4) "-" = Not Regulated

RoHS Directive (EU) 2015/863 amending Annex II to Directive 2011/65/EU

- Test Method :
- (1)With reference to IEC 62321-5:2013, determination of Cadmium by ICP-OES.
 - (2)With reference to IEC 62321-5:2013, determination of Lead by ICP-OES.
 - (3)With reference to IEC 62321-4:2013, determination of Mercury by ICP-OES.
 - (4)With reference to IEC 62321:2008, determination of Hexavalent Chromium by Colorimetric Method using UV-Vis.
 - (5)With reference to IEC 62321-6:2015, determination of PBBs and PBDEs by GC-MS.
 - (6)With reference to IEC 62321-8:2013 (111/321/CD) , determination of phthalates by GC-MS.

Test Item(s)	Limit	Unit	MDL	001	002	006
Cadmium (Cd)	100	mg/kg	2	ND	ND	ND
Lead (Pb)	1,000	mg/kg	2	ND	ND	ND
Mercury (Hg)	1,000	mg/kg	2	ND	ND	ND
Hexavalent Chromium (CrVI)	1,000	mg/kg	2	ND	ND	ND
Sum of PBBs	1,000	mg/kg	-	ND	ND	ND
Monobromobiphenyl	-	mg/kg	5	ND	ND	ND
Dibromobiphenyl	-	mg/kg	5	ND	ND	ND
Tribromobiphenyl	-	mg/kg	5	ND	ND	ND



Unless otherwise agreed in writing, this document is issued by the Company subject to its General Conditions of Service printed overleaf, available on request or accessible at <http://www.sgs.com/en/Terms-and-Conditions.aspx> and, for electronic format documents, subject to Terms and Conditions for Electronic Documents at <http://www.sgs.com/en/Terms-and-Conditions/Terms-e-Documents.aspx>. Attention is drawn to the limitation of liability, indemnification and jurisdiction issues defined therein. Any holder of this document is advised that information contained hereon reflects the Company's findings at the time of its intervention only and within the limits of Client's instructions, if any. The Company's sole responsibility is to its Client and this document does not exonerate parties to a transaction from exercising all their rights and obligations under the transaction documents. This document cannot be reproduced except in full, without prior written approval of the Company. Any unauthorized alteration, forgery or falsification of the content or appearance of this document is unlawful and offenders may be prosecuted to the fullest extent of the law. Unless otherwise stated the results shown in this test report refer only to the sample(s) tested.

Attention: To check the authenticity of testing / inspection report & certificate, please contact us at telephone: (86-755) 8307 1443, or email: CN.Doccheck@sgs.com

Test Report

No. SZXEC1700253401

Date: 10 Apr 2017

Page 3 of 13

Test Item(s)	Limit	Unit	MDL	001	002	006
Tetrabromobiphenyl	-	mg/kg	5	ND	ND	ND
Pentabromobiphenyl	-	mg/kg	5	ND	ND	ND
Hexabromobiphenyl	-	mg/kg	5	ND	ND	ND
Heptabromobiphenyl	-	mg/kg	5	ND	ND	ND
Octabromobiphenyl	-	mg/kg	5	ND	ND	ND
Nonabromobiphenyl	-	mg/kg	5	ND	ND	ND
Decabromobiphenyl	-	mg/kg	5	ND	ND	ND
Sum of PBDEs	1,000	mg/kg	-	ND	ND	ND
Monobromodiphenyl ether	-	mg/kg	5	ND	ND	ND
Dibromodiphenyl ether	-	mg/kg	5	ND	ND	ND
Tribromodiphenyl ether	-	mg/kg	5	ND	ND	ND
Tetrabromodiphenyl ether	-	mg/kg	5	ND	ND	ND
Pentabromodiphenyl ether	-	mg/kg	5	ND	ND	ND
Hexabromodiphenyl ether	-	mg/kg	5	ND	ND	ND
Heptabromodiphenyl ether	-	mg/kg	5	ND	ND	ND
Octabromodiphenyl ether	-	mg/kg	5	ND	ND	ND
Nonabromodiphenyl ether	-	mg/kg	5	ND	ND	ND
Decabromodiphenyl ether	-	mg/kg	5	ND	ND	ND
Dibutyl Phthalate (DBP)	1000	mg/kg	50			ND
Butyl benzyl Phthalate (BBP)	1000	mg/kg	50			ND
Bis (2-ethylhexyl) Phthalate (DEHP)	1000	mg/kg	50			ND
Diisobutyl Phthalates (DIBP)	1000	mg/kg	50			ND

Test Item(s)	Limit	Unit	MDL	007	008
Cadmium (Cd)	100	mg/kg	2	ND	ND
Lead (Pb)	1,000	mg/kg	2	ND	ND
Mercury (Hg)	1,000	mg/kg	2	ND	ND
Hexavalent Chromium (CrVI)	1,000	mg/kg	2	ND	ND
Sum of PBBs	1,000	mg/kg	-	ND	ND
Monobromobiphenyl	-	mg/kg	5	ND	ND
Dibromobiphenyl	-	mg/kg	5	ND	ND
Tribromobiphenyl	-	mg/kg	5	ND	ND
Tetrabromobiphenyl	-	mg/kg	5	ND	ND
Pentabromobiphenyl	-	mg/kg	5	ND	ND
Hexabromobiphenyl	-	mg/kg	5	ND	ND
Heptabromobiphenyl	-	mg/kg	5	ND	ND
Octabromobiphenyl	-	mg/kg	5	ND	ND
Nonabromobiphenyl	-	mg/kg	5	ND	ND
Decabromobiphenyl	-	mg/kg	5	ND	ND

Unless otherwise agreed in writing, this document is issued by the Company subject to its General Conditions of Service printed overleaf, available on request or accessible at <http://www.sgs.com/en/Terms-and-Conditions.aspx> and, for electronic format documents, subject to Terms and Conditions for Electronic Documents at <http://www.sgs.com/en/Terms-and-Conditions/Terms-e-Documents.aspx>. Attention is drawn to the limitation of liability, indemnification and jurisdiction issues defined therein. Any holder of this document is advised that information contained hereon reflects the Company's findings at the time of its intervention only and within the limits of Client's instructions, if any. The Company's sole responsibility is to its Client and this document does not exonerate parties to a transaction from exercising all their rights and obligations under the transaction documents. This document cannot be reproduced except in full, without prior written approval of the Company. Any unauthorized alteration, forgery or falsification of the content or appearance of this document is unlawful and offenders may be prosecuted to the fullest extent of the law. Unless otherwise stated the results shown in this test report refer only to the sample(s) tested.

Attention: To check the authenticity of testing / inspection report & certificate, please contact us at telephone: (86-755) 8307 1443, or email: CN.Doccheck@sgs.com



SGS Bldg, No.3, Jianghao Industrial Park, No.430, Jihua Road, Banlan, Longgang District, Shenzhen, China 518129 t (86-755) 25328888 f (86-755) 83106190 www.sgsgroup.com.cn
 中国·深圳·龙岗区坂田吉华路430号江灏工业园3栋SGS大楼 邮编: 518129 t (86-755) 25328888 f (86-755) 83106190 e sgs.china@sgs.com

Test Report

No. SZXEC1700253401

Date: 10 Apr 2017

Page 4 of 13

Test Item(s)	Limit	Unit	MDL	007	008
Sum of PBDEs	1,000	mg/kg	-	ND	ND
Monobromodiphenyl ether	-	mg/kg	5	ND	ND
Dibromodiphenyl ether	-	mg/kg	5	ND	ND
Tribromodiphenyl ether	-	mg/kg	5	ND	ND
Tetrabromodiphenyl ether	-	mg/kg	5	ND	ND
Pentabromodiphenyl ether	-	mg/kg	5	ND	ND
Hexabromodiphenyl ether	-	mg/kg	5	ND	ND
Heptabromodiphenyl ether	-	mg/kg	5	ND	ND
Octabromodiphenyl ether	-	mg/kg	5	ND	ND
Nonabromodiphenyl ether	-	mg/kg	5	ND	ND
Decabromodiphenyl ether	-	mg/kg	5	ND	ND
Dibutyl Phthalate (DBP)	1000	mg/kg	50	ND	
Butyl benzyl Phthalate (BBP)	1000	mg/kg	50	ND	
Bis (2-ethylhexyl) Phthalate (DEHP)	1000	mg/kg	50	ND	
Diisobutyl Phthalates (DIBP)	1000	mg/kg	50	ND	

Notes :

- (1) The maximum permissible limit is quoted from RoHS Directive (EU) 2015/863.
- (2) On 4 June 2015, Commission Directive (EU) 2015/863 was published in the Official Journal of the European Union (OJEU) to include the phthalates BBP, DBP, DEHP and DIBP into ANNEX II of the Rohs Recast Directive. The new law restricts each phthalate to no more than 0.1% in each homogeneous material of an electrical product.
- (3) The restriction of DEHP, BBP, DBP and DIBP shall apply to medical devices, including in vitro medical devices, and monitoring and control instruments, including industrial monitoring and control instruments, from 22 July 2021.
- (4) The restriction of DEHP, BBP, DBP and DIBP shall not apply to cables or spare parts for the repair, the reuse, the updating of functionalities or upgrading of capacity of EEE placed on the market before 22 July 2019, and of medical devices, including in vitro medical devices, and monitoring and control instruments, including industrial monitoring and control instruments, placed on the market before 22 July 2021.
- (5) The restriction of DEHP, BBP and DBP shall not apply to toys which are already subject to the restriction of DEHP, BBP and DBP through entry 51 of Annex XVII to Regulation (EC) No 1907/2006.'

RoHS Directive (EU) 2015/863 amending Annex II to Directive 2011/65/EU

- Test Method :
- (1)With reference to IEC 62321-5:2013, determination of Cadmium by ICP-OES.
 - (2)With reference to IEC 62321-5:2013, determination of Lead by ICP-OES.
 - (3)With reference to IEC 62321-4:2013, determination of Mercury by ICP-OES.
 - (4)With reference to IEC 62321-7-1:2015 , determination of Hexavalent Chromium by Colorimetric Method using UV-Vis.



Unless otherwise agreed in writing, this document is issued by the Company subject to its General Conditions of Service printed overleaf, available on request or accessible at <http://www.sgs.com/en/Terms-and-Conditions.aspx> and, for electronic format documents, subject to Terms and Conditions for Electronic Documents at <http://www.sgs.com/en/Terms-and-Conditions/Terms-e-Documents.aspx>. Attention is drawn to the limitation of liability, indemnification and jurisdiction issues defined therein. Any holder of this document is advised that information contained hereon reflects the Company's findings at the time of its intervention only and within the limits of Client's instructions, if any. The Company's sole responsibility is to its Client and this document does not exonerate parties to a transaction from exercising all their rights and obligations under the transaction documents. This document cannot be reproduced except in full, without prior written approval of the Company. Any unauthorized alteration, forgery or falsification of the content or appearance of this document is unlawful and offenders may be prosecuted to the fullest extent of the law. Unless otherwise stated the results shown in this test report refer only to the sample(s) tested.

Attention: To check the authenticity of testing / inspection report & certificate, please contact us at telephone: (86-755) 8307 1443, or email: CN.Doccheck@sgs.com

SGS-CSTC Testing Services Co., Ltd.
Shenzhen Branch Testing Center Chemical Laboratory

SGS Bldg, No.3, Jianghao Industrial Park, No.430, Jihua Road, Banliao, Longgang District, Shenzhen, China 518129 t (86-755) 25328888 f (86-755) 83106190 www.sgsgroup.com.cn
中国·深圳·龙岗区坂田吉华路430号江灏工业园3栋SGS大楼 邮编: 518129 t (86-755) 25328888 f (86-755) 83106190 e sgs.china@sgs.com

Test Report

No. SZXEC1700253401

Date: 10 Apr 2017

Page 5 of 13

Test Item(s)	Limit	Unit	MDL	003	004	005
Cadmium (Cd)	100	mg/kg	2	ND	ND	ND
Lead (Pb)	1,000	mg/kg	2	ND	ND	ND
Mercury (Hg)	1,000	mg/kg	2	ND	ND	ND
Hexavalent Chromium (Cr(VI))▼	-	µg/cm ²	0.10	ND	ND	ND

Test Item(s)	Limit	Unit	MDL	009
Cadmium (Cd)	100	mg/kg	2	ND
Lead (Pb)	1,000	mg/kg	2	ND
Mercury (Hg)	1,000	mg/kg	2	ND
Hexavalent Chromium (Cr(VI))▼	-	µg/cm ²	0.10	ND

Notes :

- (1) The maximum permissible limit is quoted from RoHS Directive (EU) 2015/863.
- (2) ▼= a. The sample is positive for CrVI if the CrVI concentration is greater than 0.13 µg/cm². The sample coating is considered to contain CrVI
 - b. The sample is negative for CrVI if CrVI is ND (concentration less than 0.10 µg/cm²). The coating is considered a non-CrVI based coating
 - c. The result between 0.10 µg/cm² and 0.13 µg/cm² is considered to be inconclusive - unavoidable coating variations may influence the determination

Information on storage conditions and production date of the tested sample is unavailable and thus Cr(VI) results represent status of the sample at the time of testing.

IEC 62321 series is equivalent to EN 62321 series

http://www.cenelec.eu/dyn/www/f?p=104:30:1742232870351101:::FSP_ORG_ID,FSP_LANG_ID:1258637,25

Halogen

Test Method : With reference to EN 14582:2016, analysis was performed by Ion Chromatograph (IC).

Test Item(s)	Unit	MDL	006	007
Fluorine (F)	mg/kg	50	215	ND
Chlorine (Cl)	mg/kg	50	111	ND
Bromine (Br)	mg/kg	50	ND	ND
Iodine (I)	mg/kg	50	ND	ND

Remark: The result(s) of 001 shown is/are of the total weight of wet sample.



Unless otherwise agreed in writing, this document is issued by the Company subject to its General Conditions of Service printed overleaf, available on request or accessible at <http://www.sgs.com/en/Terms-and-Conditions.aspx> and, for electronic format documents, subject to Terms and Conditions for Electronic Documents at <http://www.sgs.com/en/Terms-and-Conditions/Terms-e-Documents.aspx>. Attention is drawn to the limitation of liability, indemnification and jurisdiction issues defined therein. Any holder of this document is advised that information contained hereon reflects the Company's findings at the time of its intervention only and within the limits of Client's instructions, if any. The Company's sole responsibility is to its Client and this document does not exonerate parties to a transaction from exercising all their rights and obligations under the transaction documents. This document cannot be reproduced except in full, without prior written approval of the Company. Any unauthorized alteration, forgery or falsification of the content or appearance of this document is unlawful and offenders may be prosecuted to the fullest extent of the law. Unless otherwise stated the results shown in this test report refer only to the sample(s) tested.

Attention: To check the authenticity of testing / inspection report & certificate, please contact us at telephone: (86-755) 8307 1443, or email: CN.Doccheck@sgs.com

SGS Bldg, No.3, Jianghao Industrial Park, No.430, Jihua Road, Banliao, Longgang District, Shenzhen, China 518129 t (86-755) 25328888 f (86-755) 83106190 www.sgs.com.cn
中国·深圳·龙岗区坂田吉华路430号江灏工业园3栋SGS大楼 邮编: 518129 t (86-755) 25328888 f (86-755) 83106190 e sgs.china@sgs.com

ATTACHMENTS

Pb/Cd/Hg/Cr⁶⁺/PBBs/PBDEs Testing Flow Chart

- 1) Name of the person who made testing: Winsen Deng / David Mai / Truly Ren
- 2) Name of the person in charge of testing: Zoe Luo / Laurel Li / Muky Tong /
- 3) These samples were dissolved totally by pre-conditioning method according to below flow chart (Cr⁶⁺ and PBBs/PBDEs test method excluded).

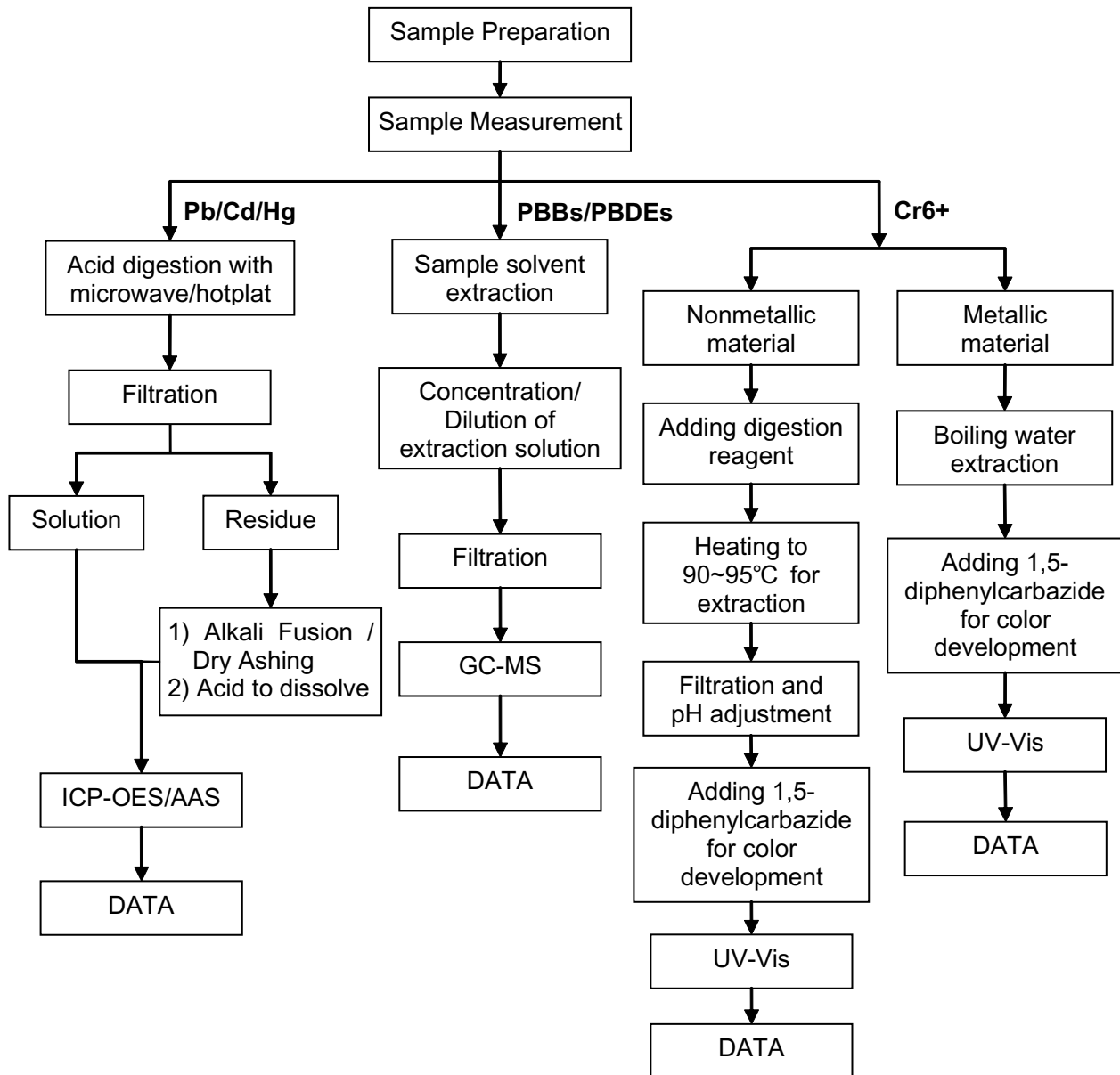

Unless otherwise agreed in writing, this document is issued by the Company subject to its General Conditions of Service printed overleaf, available on request or accessible at <http://www.sgs.com/en/Terms-and-Conditions.aspx> and, for electronic format documents, subject to Terms and Conditions for Electronic Documents at <http://www.sgs.com/en/Terms-and-Conditions/Terms-e-Documents.aspx>. Attention is drawn to the limitation of liability, indemnification and jurisdiction issues defined therein. Any holder of this document is advised that information contained hereon reflects the Company's findings at the time of its intervention only and within the limits of Client's instructions, if any. The Company's sole responsibility is to its Client and this document does not exonerate parties to a transaction from exercising all their rights and obligations under the transaction documents. This document cannot be reproduced except in full, without prior written approval of the Company. Any unauthorized alteration, forgery or falsification of the content or appearance of this document is unlawful and offenders may be prosecuted to the fullest extent of the law. Unless otherwise stated the results shown in this test report refer only to the sample(s) tested.

Attention: To check the authenticity of testing / inspection report & certificate, please contact us at telephone: (86-755) 8307 1443, or email: CN.Doccheck@sgs.com

ATTACHMENTS

Phthalates Testing Flow Chart

- 1) Name of the person who made testing: David Mai
- 2) Name of the person in charge of testing: Laurel Li

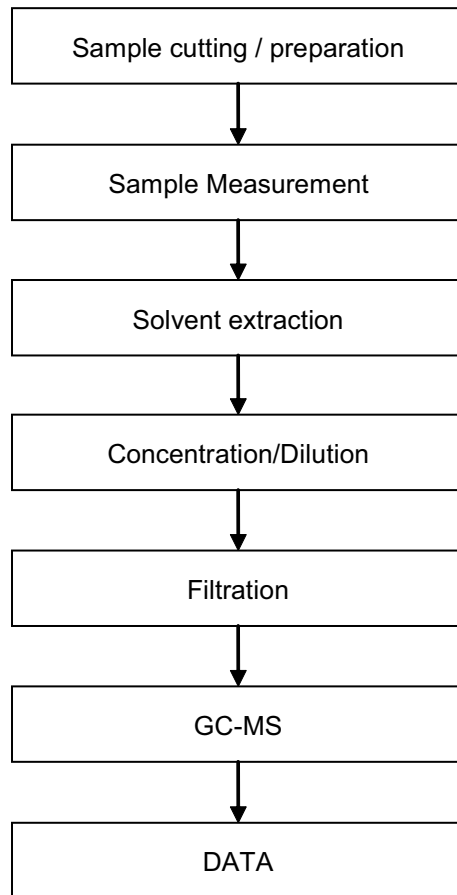

Unless otherwise agreed in writing, this document is issued by the Company subject to its General Conditions of Service printed overleaf, available on request or accessible at <http://www.sgs.com/en/Terms-and-Conditions.aspx> and, for electronic format documents, subject to Terms and Conditions for Electronic Documents at <http://www.sgs.com/en/Terms-and-Conditions/Terms-e-Documents.aspx>. Attention is drawn to the limitation of liability, indemnification and jurisdiction issues defined therein. Any holder of this document is advised that information contained hereon reflects the Company's findings at the time of its intervention only and within the limits of Client's instructions, if any. The Company's sole responsibility is to its Client and this document does not exonerate parties to a transaction from exercising all their rights and obligations under the transaction documents. This document cannot be reproduced except in full, without prior written approval of the Company. Any unauthorized alteration, forgery or falsification of the content or appearance of this document is unlawful and offenders may be prosecuted to the fullest extent of the law. Unless otherwise stated the results shown in this test report refer only to the sample(s) tested.

Attention: To check the authenticity of testing / inspection report & certificate, please contact us at telephone: (86-755) 8307 1443, or email: CN.Doccheck@sgs.com

ATTACHMENTS

Halogen Testing Flow Chart

- 1) Name of the person who made testing: Abel Li
- 2) Name of the person in charge of testing: Roje Zhou

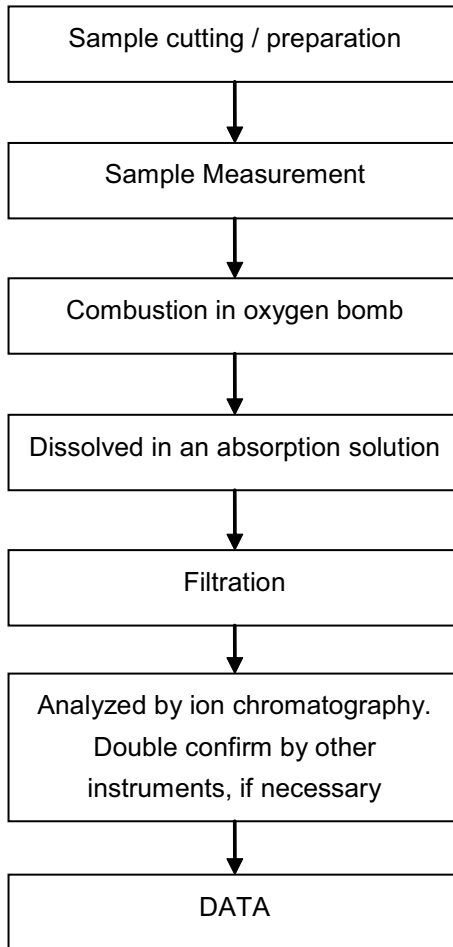

Unless otherwise agreed in writing, this document is issued by the Company subject to its General Conditions of Service printed overleaf, available on request or accessible at <http://www.sgs.com/en/Terms-and-Conditions.aspx> and, for electronic format documents, subject to Terms and Conditions for Electronic Documents at <http://www.sgs.com/en/Terms-and-Conditions/Terms-e-Documents.aspx>. Attention is drawn to the limitation of liability, indemnification and jurisdiction issues defined therein. Any holder of this document is advised that information contained hereon reflects the Company's findings at the time of its intervention only and within the limits of Client's instructions, if any. The Company's sole responsibility is to its Client and this document does not exonerate parties to a transaction from exercising all their rights and obligations under the transaction documents. This document cannot be reproduced except in full, without prior written approval of the Company. Any unauthorized alteration, forgery or falsification of the content or appearance of this document is unlawful and offenders may be prosecuted to the fullest extent of the law. Unless otherwise stated the results shown in this test report refer only to the sample(s) tested.

Attention: To check the authenticity of testing / inspection report & certificate, please contact us at telephone: (86-755) 8307 1443, or email: CN.Doccheck@sgs.com

Sample photo:



Unless otherwise agreed in writing, this document is issued by the Company subject to its General Conditions of Service printed overleaf, available on request or accessible at <http://www.sgs.com/en/Terms-and-Conditions.aspx> and, for electronic format documents, subject to Terms and Conditions for Electronic Documents at <http://www.sgs.com/en/Terms-and-Conditions/Terms-e-Documents.aspx>. Attention is drawn to the limitation of liability, indemnification and jurisdiction issues defined therein. Any holder of this document is advised that information contained hereon reflects the Company's findings at the time of its intervention only and within the limits of Client's instructions, if any. The Company's sole responsibility is to its Client and this document does not exonerate parties to a transaction from exercising all their rights and obligations under the transaction documents. This document cannot be reproduced except in full, without prior written approval of the Company. Any unauthorized alteration, forgery or falsification of the content or appearance of this document is unlawful and offenders may be prosecuted to the fullest extent of the law. Unless otherwise stated the results shown in this test report refer only to the sample(s) tested.

Attention: To check the authenticity of testing / inspection report & certificate, please contact us at telephone: (86-755) 8307 1443, or email: CN.Doccheck@sgs.com

SGS Bldg, No.3, Jiangheo Industrial Park, No.430, Jihua Road, Banlian, Longgang District, Shenzhen, China 518129 t (86-755) 25328888 f (86-755) 83106190 www.sgs.com.cn
 中国·深圳·龙岗区坂田吉华路430号江源工业园3栋SGS大楼 邮编: 518129 t (86-755) 25328888 f (86-755) 83106190 e sgs.china@sgs.com

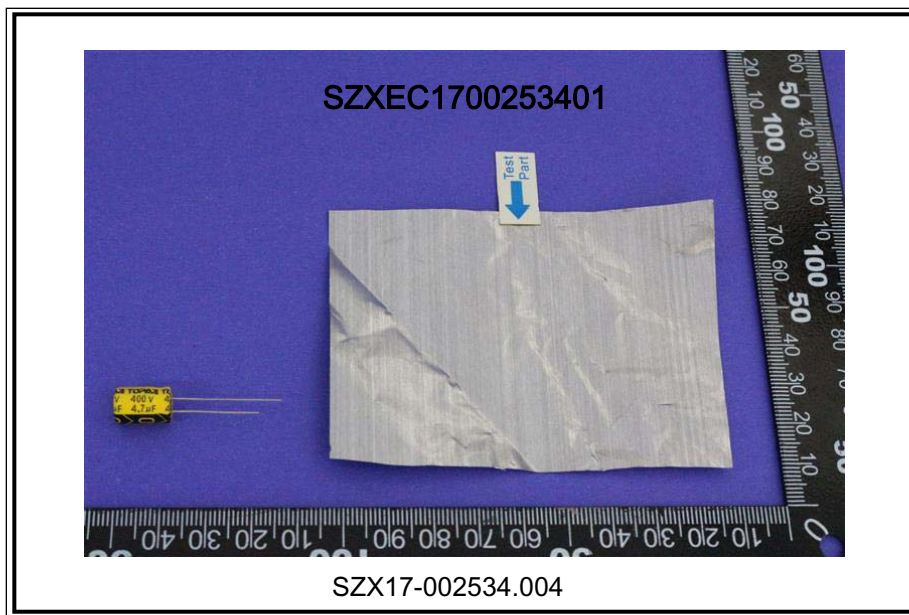
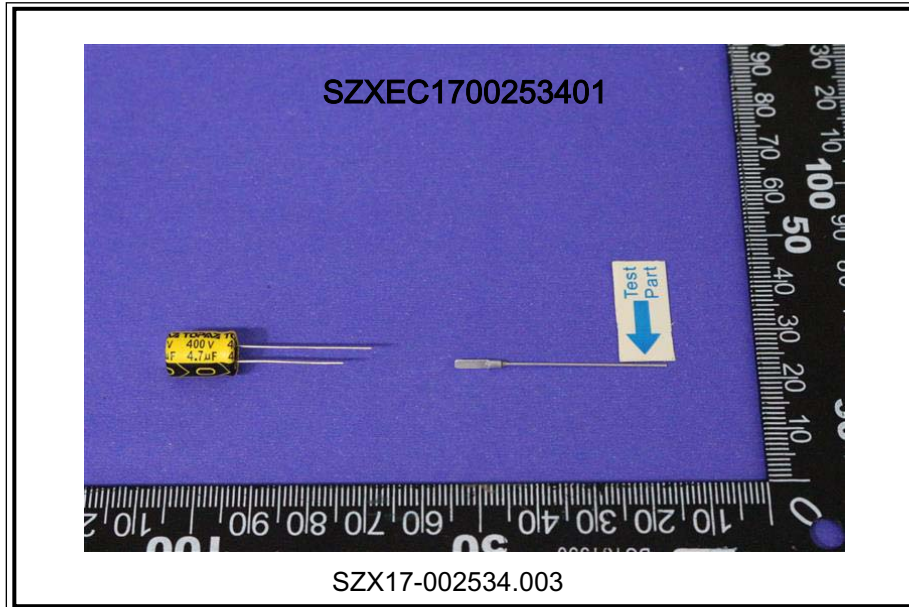

Unless otherwise agreed in writing, this document is issued by the Company subject to its General Conditions of Service printed overleaf, available on request or accessible at <http://www.sgs.com/en/Terms-and-Conditions.aspx> and, for electronic format documents, subject to Terms and Conditions for Electronic Documents at <http://www.sgs.com/en/Terms-and-Conditions/Terms-e-Documents.aspx>. Attention is drawn to the limitation of liability, indemnification and jurisdiction issues defined therein. Any holder of this document is advised that information contained hereon reflects the Company's findings at the time of its intervention only and within the limits of Client's instructions, if any. The Company's sole responsibility is to its Client and this document does not exonerate parties to a transaction from exercising all their rights and obligations under the transaction documents. This document cannot be reproduced except in full, without prior written approval of the Company. Any unauthorized alteration, forgery or falsification of the content or appearance of this document is unlawful and offenders may be prosecuted to the fullest extent of the law. Unless otherwise stated the results shown in this test report refer only to the sample(s) tested.

Attention: To check the authenticity of testing / inspection report & certificate, please contact us at telephone: (86-755) 8307 1443, or email: CN.Doccheck@sgs.com

SGS Bldg, No.3, Jianghao Industrial Park, No.430, Jinhua Road, Banliao, Longgang District, Shenzhen, China 518129 t (86-755) 25328888 f (86-755) 83106190 www.sgsgroup.com.cn
中国·深圳·龙岗区坂田吉华路430号江灏工业园3栋SGS大楼 邮编: 518129 t (86-755) 25328888 f (86-755) 83106190 e sgs.china@sgs.com

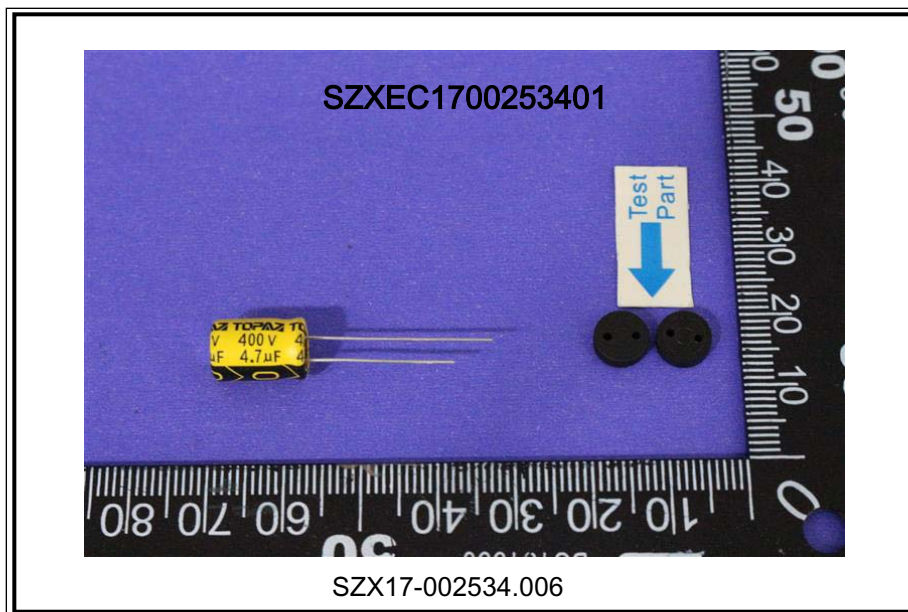
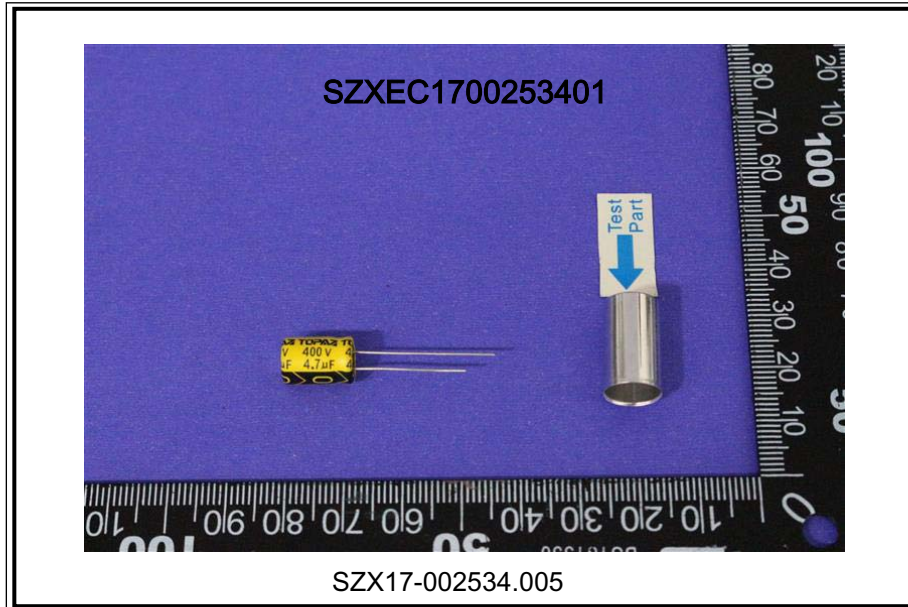

Unless otherwise agreed in writing, this document is issued by the Company subject to its General Conditions of Service printed overleaf, available on request or accessible at <http://www.sgs.com/en/Terms-and-Conditions.aspx> and, for electronic format documents, subject to Terms and Conditions for Electronic Documents at <http://www.sgs.com/en/Terms-and-Conditions/Terms-e-Documents.aspx>. Attention is drawn to the limitation of liability, indemnification and jurisdiction issues defined therein. Any holder of this document is advised that information contained hereon reflects the Company's findings at the time of its intervention only and within the limits of Client's instructions, if any. The Company's sole responsibility is to its Client and this document does not exonerate parties to a transaction from exercising all their rights and obligations under the transaction documents. This document cannot be reproduced except in full, without prior written approval of the Company. Any unauthorized alteration, forgery or falsification of the content or appearance of this document is unlawful and offenders may be prosecuted to the fullest extent of the law. Unless otherwise stated the results shown in this test report refer only to the sample(s) tested.

Attention: To check the authenticity of testing / inspection report & certificate, please contact us at telephone: (86-755) 8307 1443, or email: CN.Doccheck@sgs.com

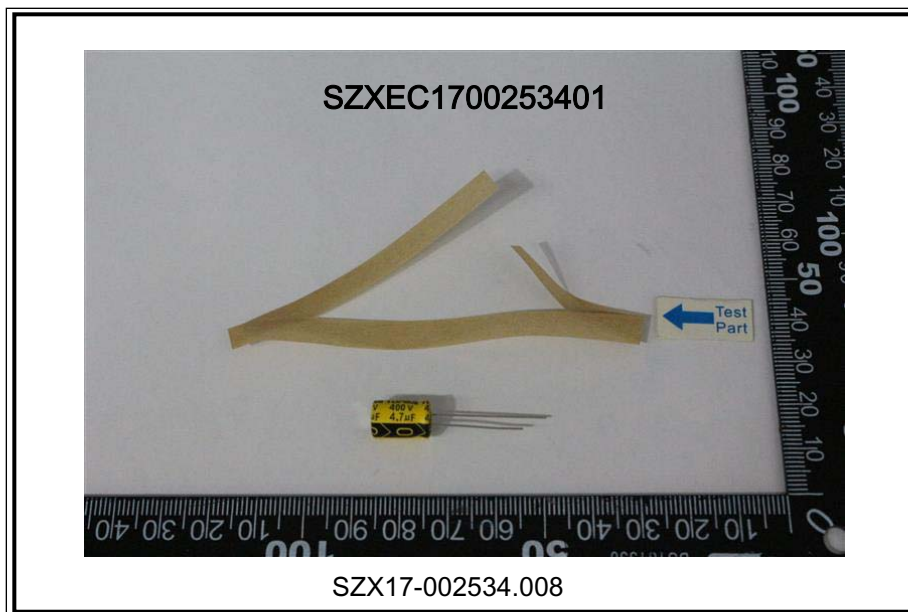
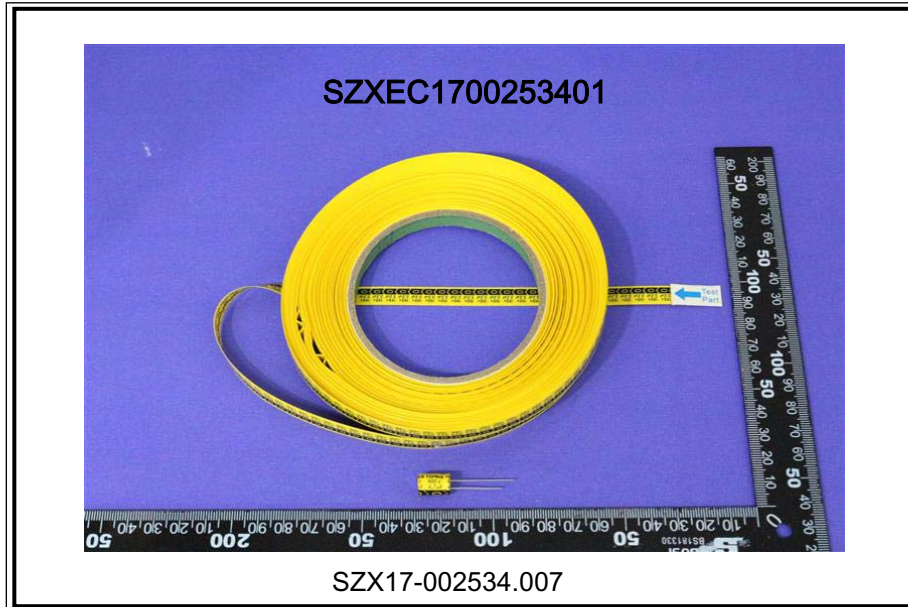

Unless otherwise agreed in writing, this document is issued by the Company subject to its General Conditions of Service printed overleaf, available on request or accessible at <http://www.sgs.com/en/Terms-and-Conditions.aspx> and, for electronic format documents, subject to Terms and Conditions for Electronic Documents at <http://www.sgs.com/en/Terms-and-Conditions/Terms-e-Documents.aspx>. Attention is drawn to the limitation of liability, indemnification and jurisdiction issues defined therein. Any holder of this document is advised that information contained hereon reflects the Company's findings at the time of its intervention only and within the limits of Client's instructions, if any. The Company's sole responsibility is to its Client and this document does not exonerate parties to a transaction from exercising all their rights and obligations under the transaction documents. This document cannot be reproduced except in full, without prior written approval of the Company. Any unauthorized alteration, forgery or falsification of the content or appearance of this document is unlawful and offenders may be prosecuted to the fullest extent of the law. Unless otherwise stated the results shown in this test report refer only to the sample(s) tested.

Attention: To check the authenticity of testing / inspection report & certificate, please contact us at telephone: (86-755) 8307 1443, or email: CN.Doccheck@sgs.com

SGS Bldg, No.3, Jianghao Industrial Park, No.430, Jihua Road, Banlan, Longgang District, Shenzhen, China 518129 t (86-755) 25328888 f (86-755) 83106190 www.sgsgroup.com.cn
中国·深圳·龙岗区坂田吉华路430号江灏工业园3栋SGS大楼 邮编: 518129 t (86-755) 25328888 f (86-755) 83106190 e sgs.china@sgs.com

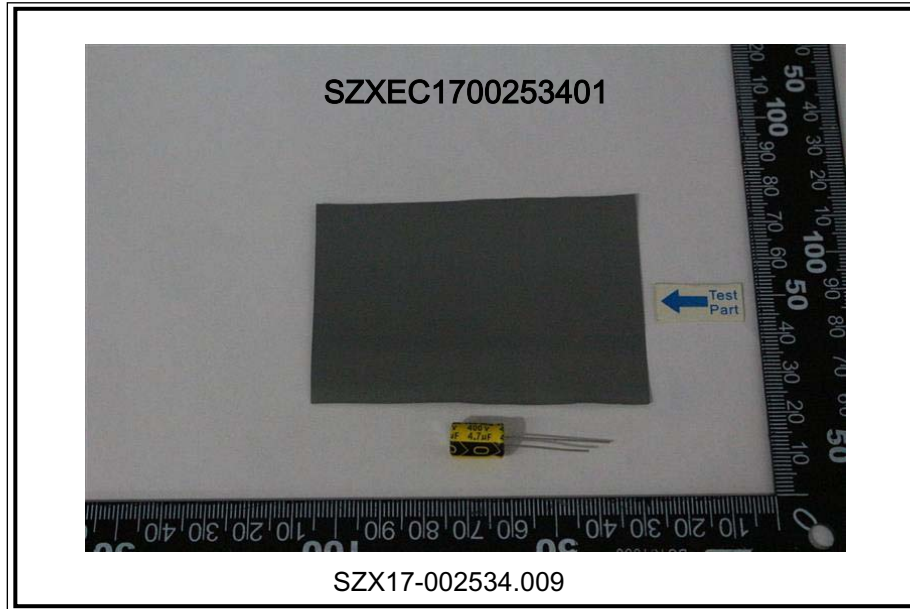

SGS authenticate the photo on original report only

*** End of Report ***



Unless otherwise agreed in writing, this document is issued by the Company subject to its General Conditions of Service printed overleaf, available on request or accessible at <http://www.sgs.com/en/Terms-and-Conditions.aspx> and, for electronic format documents, subject to Terms and Conditions for Electronic Documents at <http://www.sgs.com/en/Terms-and-Conditions/Terms-e-Documents.aspx>. Attention is drawn to the limitation of liability, indemnification and jurisdiction issues defined therein. Any holder of this document is advised that information contained hereon reflects the Company's findings at the time of its intervention only and within the limits of Client's instructions, if any. The Company's sole responsibility is to its Client and this document does not exonerate parties to a transaction from exercising all their rights and obligations under the transaction documents. This document cannot be reproduced except in full, without prior written approval of the Company. Any unauthorized alteration, forgery or falsification of the content or appearance of this document is unlawful and offenders may be prosecuted to the fullest extent of the law. Unless otherwise stated the results shown in this test report refer only to the sample(s) tested.

Attention: To check the authenticity of testing / inspection report & certificate, please contact us at telephone: (86-755) 8307 1443, or email: CN.Doccheck@sgs.com

SGS-CSTC 检验检测专用章
Inspection & Testing Services
Shenzhen Branch Testing Center Chemical Laboratory

SGS Bldg, No.3, Jiangtao Industrial Park, No.430, Jihua Road, Banlan, Longgang District, Shenzhen, China 518129 t (86-755) 25328888 f (86-755) 83106190 www.sgs.com.cn
中国·深圳·龙岗区坂田吉华路430号江灏工业园3栋SGS大楼 邮编: 518129 t (86-755) 25328888 f (86-755) 83106190 e sgs.china@sgs.com