

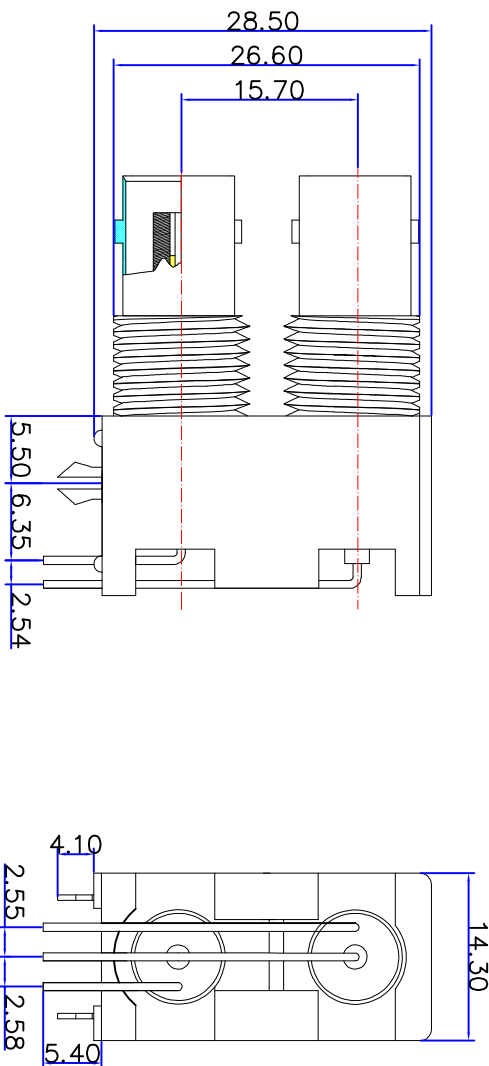

Customer NO: DOSIN-801-0093		DWN		DATE	APPROVEN
REV	DESCRIPTION	DWN		DATE	APPROVEN
A	First issue	Mr. chen		2016/3/03	John kine
B	以实物调整尺寸	W. cheng		2020/09/22	John kine

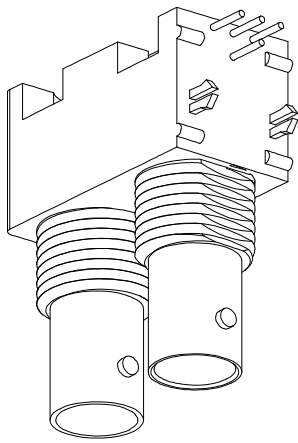

### Specifications:

IMPEDANCE: 50 Ohms  
 Frequency range: 0~3GHZ  
 VSWR: 1.5MAX  
 Working voltage: 500V rms @ sea level  
 Insulation resistance: 5000 Ohms min  
 Temperature range: -55°C T0 +155°C  
 Relative temperature: ≤95% (40° C ±2° C)

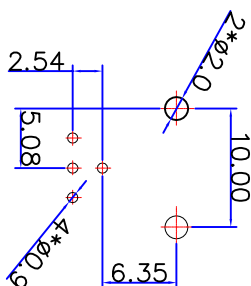
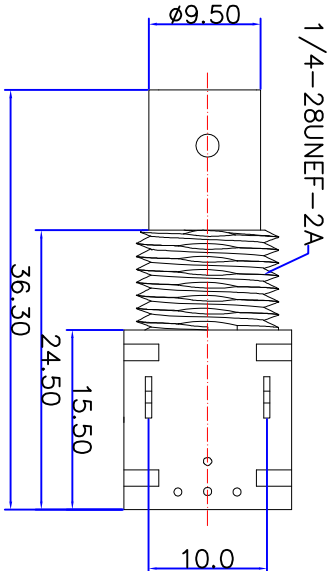

1	BODY	Zinc	NICKEL	2	NOTE:				
2	PIN	Brass	GOLD	2					
3	INSULATOR	POM	White	2					
4	PLASTIC BODY	PBT	White	1					
5	EARTH WIRE	IRON	NICKEL	2	DRAWN				
6	FIXED FOOT	IRON	NICKEL	2	Zelin.chen				
7					CHECKED				
8									
9									
10									
NO	Component Number	Material	Finish	QTY	APPROVALS	SCALE	UNIT	MM	REV
A					John Kine	1:1			A

**DOSIN** Dosin Industrial (HK) Co., Ltd  
 东莞市德泰五金电子有限公司  
 Dosin Hardware Electronics Co., Ltd

Name: BNC Jack PCB Mount

SIZE: A  
 Date/Time: 2016/3/03

Product NO: DOSIN-801-0093

CAD FILE: H/company drawings/BD

SHEET: 1 OF 1

REV: A

E-mail: dosin2005@163.com  
 dosin2005@dosin-china.com  
 Web: http://www.dosin.com  
 TEL: (0086) 769-81153906  
 FAX: (0086) 769-8187836